

Scale-Equipped Drum Pourers with Geared Drum Tilt

Weigh Drum While You Dispense

Combines V-shaped base to serve pallet corners, hand crank geared tilt control to dispense drum and scale to dispense just the amount required.



Scale indicator shows drum weight

Models with Battery, AIR or plug-in Electric Power Drum Lift.

Capacity: 600 Lb. (272 kg)



Two load cells to measure drum weight accurately to 0.2%

Shown with recommended MORStop Tilt-Brake option.

Model 825A-N-125 shown has Battery Power Drum Lift

V-Shaped Counterweighted, Base enables Palletizing Drum



- Lift, move and pour drum
- Weigh while pouring to dispense specified amount
- Move onto and off pallet or spill containment up to 16" (40.6 cm) tall
- Pour horizontal drum up 25" (63.5 cm) high



morsedrum.com



service@morsedrum.com



(315) 437-8475



103 Kuhn Rd.
 Syracuse, NY, 13208 USA

Two Types of Scales

The digital indicator keeps you informed of drum weight, so you can weigh while pouring.

Scales are simple to use and to read enabling accurate batching by weight. Touch pads include numbers for tare entry. Two load cells accurately sense weight regardless of tilt angle of drum. Battery saving “sleep” mode turns indicator off when scale is not in use.

Display weight to 0.1 Lb. (or set to display metric units). Accuracy of +/-0.2 %. Scale has NO data storage capability.

Maximum operating temperature is 104° F (40° C).

Scale components are installed and calibrated before leaving Morse factory. However, rigors of transport may change scale calibration. To assure proper accuracy, user should employ local scale service personnel to check function and calibration of scale. Cost of on-site calibration is not included in selling price.



“N” Type scale indicator NOT for hazardous environments.

N-Type Scale

Economical general purpose instrument for use in a variety of weighing applications. NOT for use in hazardous areas. Powered by five ordinary alkaline D-cell batteries.

T-Type Scale

Intrinsically safe, ultra low power intensity (ULPI) scale indicator for use in many hazardous areas, approved for all classes, groups and divisions of N.E.C. hazardous environment classifications. Manual hand pump or air power drum handler with this intrinsically safe weighing system may be used in many hazard areas where ordinary electric powered equipment would be prohibited. Comes with battery pack and 115V 60Hz charger.

For 220V/50Hz applications, battery charger will require a step down transformer - order part number 93740-P. Models with spark resistant monel parts, such as drum holder bands are indicated by an “M” in model number.



“T” Type Intrinsically safe scale indicator for use in hazardous areas.

Model #	Scale Type	Lift Function	Motor	Feature	Product Net Weight	Domestic Ship Weight *	Options & Accessories			
							MORStop Tilt-Brake	Top Rim Clamp	Bracket Assembly	Diameter Adapters
825A-N-125	N	Battery Power Lift	12V DC Motor **	-	565 Lb. (256 kg)	631 Lb. (286 kg)	3900i-P	4560B-P	4556-P	55/30 Series
825A-N-124	N	AIR Power Lift	-	-			3900i-P	4560B-P	4556-P	55/30 Series
825A-N-120	N	Plug-in Electric Lift	1PH/115V/60Hz, TEFC	-			3900i-P	4560B-P	4556-P	55/30 Series
825A-N	N	Hand Pump	-	-			3900i-P	4560B-P	4556-P	55/30 Series
825A-T-124	T	AIR Power Lift	-	-			3900i-P	4560B-P	4556-P	55/30 Series
825A-T	T	Hand Pump	-	-			3900i-P	4560B-P	4556-P	55/30 Series
825AM-T	T	Hand Pump	-	Spark Resistant Parts			3900i-P	4560BM-P	4556M-P	55/30M Series
825AM-T-124	T	AIR Power Lift	-	Spark Resistant Parts			3900i-P	4560BM-P	4556M-P	55/30M Series

* Domestic Ship Dimensions: L50" W50" H56" (127 x 127 x 142 cm)

** 12V DC Power Lift includes battery, and 115V 60Hz AC charger.

NOTE: 12V Deep Cycle Lead Acid Battery is designed for domestic shipment only. For export shipment, choose the following battery and charger options:

- Option “NB” No Battery. Customer must obtain battery before use... Exide # 27MDP 12V Deep Cycle Battery or equivalent.
- Option “NC” No Charger.

Ergonomic Power Lift Models

Manual Lift Model

Battery Power Lift
Model 825A-N-125



Battery Power Lift Control

Self contained battery power-lift. Use 2-button pendant to raise and lower the drum. 12V deep cycle battery and separate charger are included.

AIR Power Lift
Models 825A-N-124,
825AM-N-124
and 825AM-T-124

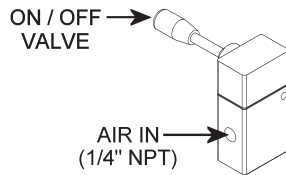

Air Power Lift Control

Use on / off valve to raise and lower the drum.

Plug-In Electric Power Lift
Model 825A-N-120

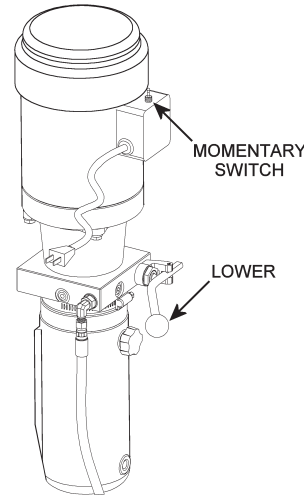

Electric Power Lift Control

Use switch to raise the drum. Lower the drum with manual release valve.

Hand Pump Lift
Models 825A-N, 825A-T
and 825AM-T

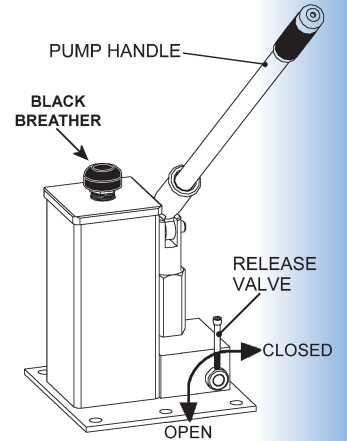

Hand Pump Lift Control

It takes 27 pumps of the hand pump to lift a drum to maximum height.

MADE
IN
USA

Options and Accessories

Morse 825A Series are designed to handle a ribbed 55-gallon (210 liter) steel drum. They also accept the options below for handling other types and sizes of drum.

Kit 4560B-P

Top Rim Clamp

to handle a 55-gallon (210 liter) rimmed plastic or fiber drum. It grips the upper rim of your drum to prevent it from slipping through the drum holder. To handle a 55-gallon plastic drum with top rim, you must install either the Bracket Assembly or the Top Rim Clamp.



Kit 4556-P

Bracket Assembly

is required to handle a rimless plastic drum, and recommended to more securely handle a fiber drum. It provides a brace at top and bottom of your drum to prevent it from slipping length-ways through the drum holder. It adjusts for a 31" to 39" (78.7 to 99 cm) tall drum.



55/30 Series Diameter Adapters

Install the correct size Diameter Adapter to handle each smaller drum. They install easily inside the drum holder without tools, and are quickly removed.

Diameter Adapters for 19" (48.3 cm) diameter or larger drum can be used in combination with the Bracket Assembly. Diameter Adapters for 17.5" (44.5 cm) diameter or smaller have integrated brackets at top and bottom of the drum that adjust for a drum up to 38" (96.5 cm) tall.

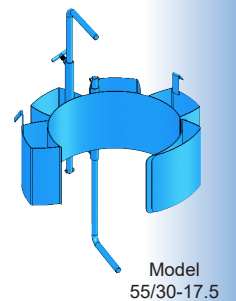

Recommended MORStop Tilt-Brake

Add factory installed **Option 3900i-P MORStop Tilt-Brake** to automatically lock and hold the drum tilt angle, until you turn the hand crank again... even if drum contents shift.

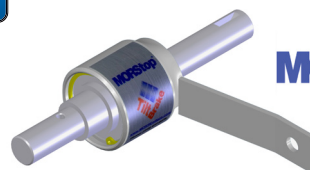

Steps to Use Morse Scale-Equipped Drum Pourers



MADE
IN
USA

1. Roll drum handler to drum with drum holder open and positioned to engage between drum ribs
2. Secure drum in holder: Drape cinch chain with flexible chain cover across front of drum. Insert one chain link into slot on ratchet handle. Turn ratchet handle clockwise to tighten cinch chain around drum.
3. Lift drum from floor or from pallet to pouring height by operating powered lift control or hand pump.
4. Turn hand crank to rotate drum into dispensing position.

NOTE: We recommend the **MORStop Tilt-Brake OPTION** to automatically hold drum tilt angle, until you turn the hand crank again.

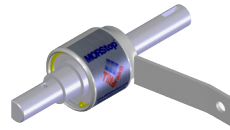

5. Note beginning drum weight on scale indicator and dispense amount of product required.
6. When done pouring drum, return to upright and lower to floor or onto pallet.
7. To remove drum from handler, release ratchet handle and open drum holder.



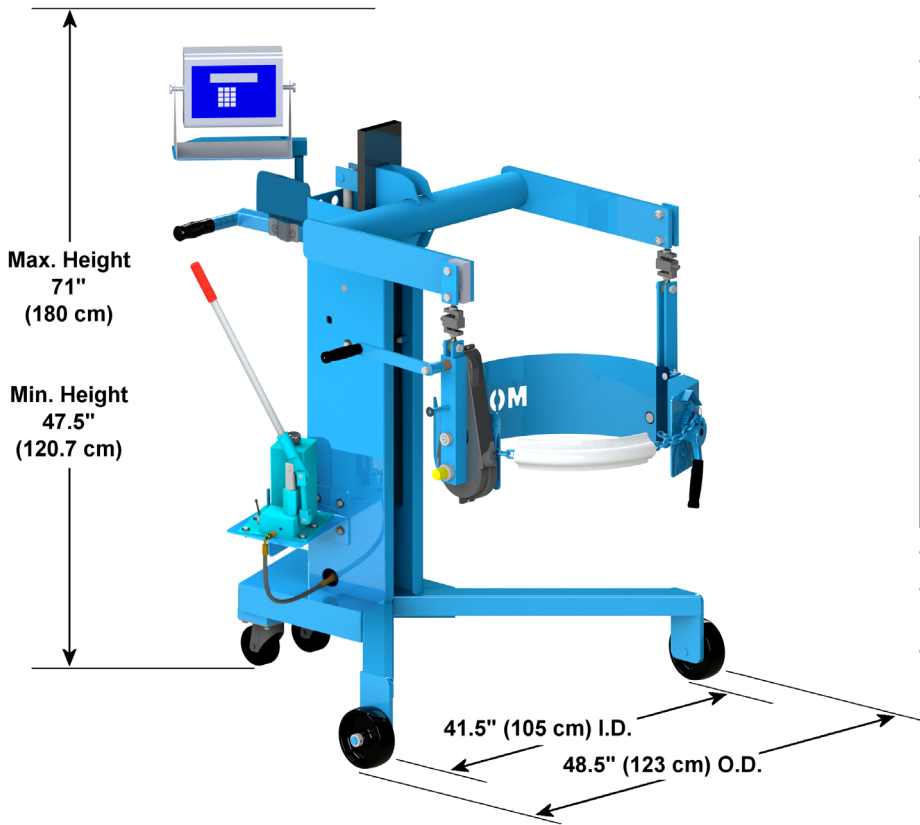

Dimensions

- Turning radius: 53" (135 cm)
- Legs are 9" (22.9 cm) high and reach 20.75" (52.7 cm) in front of upright stanchion
- (2) 4" (10.2 cm) swivel casters at back
- (2) 6" (15.2 cm) wheels at front

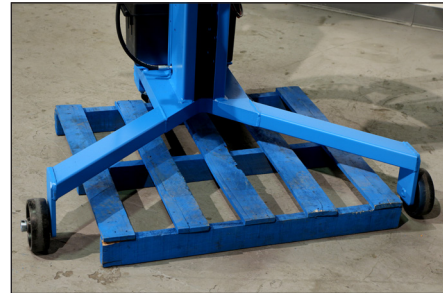

- Straddle pallet up to 41" (104 cm) wide
- Lift upright 55-gallon drum up to 16" (40.6 cm) from floor to serve pallet or spill containment
- Heavy duty hydraulic lift cylinder includes velocity fuse to provide full line shut-off in event of line failure

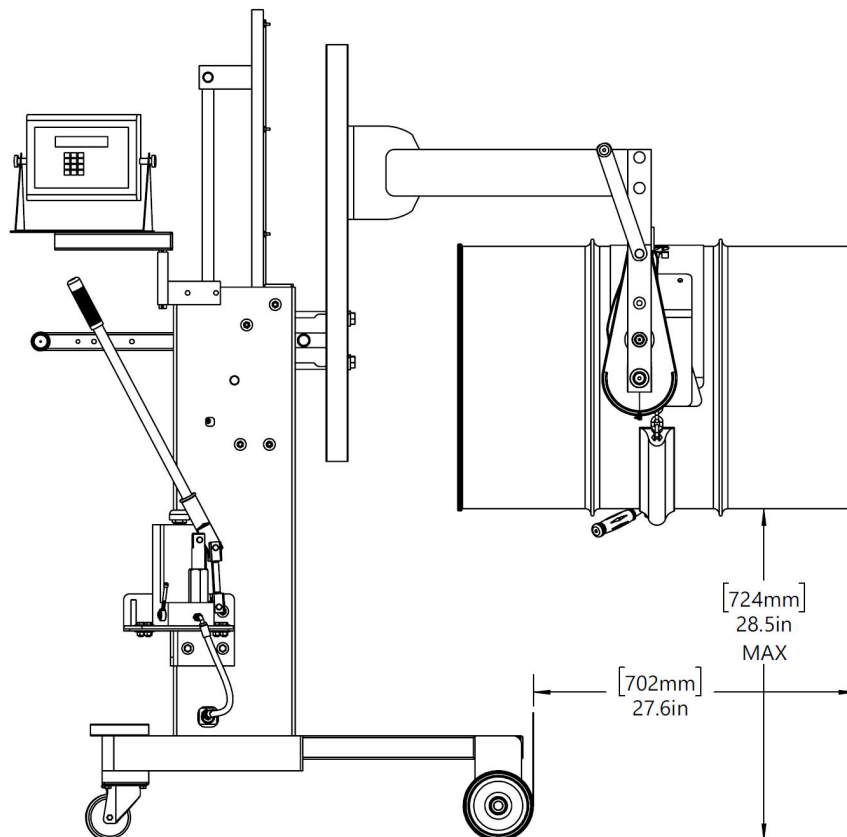

MADE
IN
USA