

OPERATOR'S MANUAL FOR MORSE 310 SERIES TILT-TO-LOAD DRUM ROTATOR Serial # 188147 to 203638

SAFETY INFORMATION:

While Morse Manufacturing Co. drum handling equipment is engineered for safety and efficiency, a high degree of responsibility must be placed upon the machine operator to follow safe practices, based primarily on common sense, upon which true safety depends.

Failure to follow the safety precautions in this manual can result in personal injury or property damage. Observe the same precautions as with similar machinery where carelessness in operating or maintenance is hazardous to personnel. Carefully read the safety precautions below and throughout this manual.



DANGER - Indicates a situation which, if not avoided, *will* result in serious injury or death. This signal word is limited to the most extreme situations.

WARNING - Indicates a situation which, if not avoided, *could* result in serious injury or death.

CAUTION - Indicates a situation which, if not avoided, can result in damage to the machine.

DANGER - **Do Not Stand Near any Part of a Rotating Drum or Drum Holder.** Operator should remain directly in front of the control station while operating the rotator (see figure on page 2). Morse Drum Rotators do not comply with OSHA unless they are installed in accordance with OSHA subpart O, 1910.212 - "General requirements for all machines." **"Revolving drums, barrels, and containers shall be guarded by an enclosure which is interlocked with the drive mechanism, so that the barrel, drum, or container cannot revolve unless the guard enclosure is in place."** (An optional safety enclosure can be ordered for any MORSE drum rotator.)

WARNING - The 310 is designed to rotate steel, plastic or fibre drums up to 800 Lb., ranging from 18" to 23½" diameter and from 29" to 37" in height. **DO NOT** attempt to handle any other type of drum or object. **DO NOT** exceed the weight capacity of 800lbs.

WARNING - **Level Floors Only.** For operation only on clean, level floors of suitable bearing capacity. Do not use on sloped surfaces, ramps, irregular or debris strewn floors.

WARNING - **Properly Mount to Floor.** *Do Not* put into service without proper floor mounting and leveling. Use the four mounting holes in each corner of the base to anchor to floor.

WARNING - **Do Not Modify the Unit.** Under no circumstances should any modifications be made to the Morse 310 machinery without factory authorization. Any modifications may void the warranty. This machine was designed to perform a specific job and alterations may result in injury to operator or machine.

WARNING - **No Loose Fitting Clothing.** Wear close-fitting clothing and safety equipment appropriate to the job. Loose fitting clothing may become caught on the machinery and cause severe personal injury.

WARNING - **Hydraulic Fluid Under Pressure Can Be Hazardous.** Escaping hydraulic fluid under pressure can penetrate the skin, causing serious injury. Avoid the hazard by relieving pressure before disconnecting hydraulic lines. Keep hands and body away from pinholes and nozzles which eject fluid under high pressure. Use a piece of cardboard to search for leaks. If an accident occurs, see a doctor immediately and inform them of the nature of the accident.

CAUTION - **Wear Safety Shoes.** Wear safety shoes with non-slip soles and hard toe protection.

MACHINE DESCRIPTION:

GENERAL

The Morse model 310 Tilt-to-Load Drum Rotator is designed to receive an upright steel, plastic or fibre drum at floor level, hydraulically tilt up to clear the floor, and rotate the drum between 5 and 20 RPM. The maximum full drum capacity is 800 Lb. Capacity is derated to 400 Lb. for a half-full drum.

CONTROLS

There are two powered functions for the operator to control:

- the "LIFT" function, or the vertical positioning of the drum holder
- the "ROTATE" function, or the rotation of the drum holder.



Control Station



Man at Control Station

Each function is controlled separately by levers mounted on the control station (see figure above):

- The lever on the *right* side is the "LIFT" control valve. Raising the lever causes the drum holder to rise. Lowering the lever will lower the drum holder.
- The lever on the *left* side is the "ROTATE" control valve. Raising this lever causes the drum holder to rotate. Lowering the lever away from the operator will stop the drum holder from rotating.

WARNING - Watch Out for Pinch Points. Stay clear of moving parts. Operator should remain in front of the control station during operation of the lift or rotate mechanisms.

Drum Holder Assembly

The drum holder assembly is the component on the Tilt-to-Load Rotator that securely holds the drum for rotating. The drum holder features the ratchet & cinch chain mechanism for tightening the drum at the middle and two top clamps for holding the drum end-to-end.

OPERATION:

CONTROL STATION

MAKING CONNECTIONS:

- 1.) For the air motor powered rotator, a filter, regulator, lubricator is mounted on the control station. A shutoff ball valve is installed on the inlet of the regulator. The air connection should be made at the inlet of this valve.
- 2.) Ensure that the supply air lines are of sufficient size to provide proper air volume. The air motor requires 40 scfm, and 50 – 60 psi of compressed air. (The proper air pressure will depend on the weight of the drum.)

LOADING A DRUM:

- 1.) With the drum holder in the lowered position, the bottom loading plate will be slightly above the floor. Swing the hinged ratchet plate clear of the drum opening. Loosen the top clamps to the full open position.
- 2.) A variety of drum handling methods can be used to set the drum into the drum holder. Ensure that the drum is fully seated against the back of the drum holder.



- 3.) Drape the cinch chain across the face of the drum and engage a link in notch in hub of ratchet. Turn ratchet until chain tightens around drum.
- 4.) Turn the top clamps until they tighten against top of drum.

ROTATING A DRUM:

- 1.) After ensuring that the drum is securely fastened into the drum holder, turn the motor on to activate the hydraulics. (For the air motor version, open the air shutoff ball valve.)

Raise the drum to the top position by raising the LIFT control valve, on the right.

DANGER

IT IS CRITICAL THAT THE DRUM HOLDER ASSEMBLY IS FULLY RAISED BEFORE ROTATING. IF THE DRUM HOLDER IS NOT IN THE FULLY RAISED POSITION WHEN ROTATING, IT CAN INTERFERE WITH THE FLOOR AND FRAME AND CAUSE SEVERE DAMAGE TO EQUIPMENT AND/OR SERIOUS INJURY OR DEATH.

Note: There is an interlock switch built into the tilt frame which is intended to prevent rotating when the drum holder is not properly positioned at its highest lift point. The true safety of this operation, however, depends on the operator correctly positioning the drum holder, and verifying that the tilt frame is fully raised.

- 2.) TO BEGIN ROTATING, RAISE THE ROTATE CONTROL VALVE.

(ALTERNATE METHOD - On the air motor version: With the air shutoff ball valve in the OFF position, raise the ROTATE valve to the ROTATE position. Then, slowly open the air shutoff ball valve to begin the rotation. This can allow for more control over the speed of rotation.)

4. MAINTENANCE

Inspect the hydraulic system for oil drips, hose damage, or other signs of wear. Inspect the level and condition of the hydraulic fluid. (See hydraulic pump specification sheet.) Replace any parts that show signs of wear.

Lubricate all moving parts including: bearings, clevis pins, and threaded rod.

Periodically inspect all moving parts, framework, and floor mounting fasteners for signs of wear, fatigue, or loosening.

PARTS DIAGRAM FOR 310 SERIES BASE ASSEMBLY Serial # 188147 to 203638

ITEM	MODEL SUFFIX	QTY	P/N	DESCRIPTION
1	-1-115, -1-230	1	3186-1-P	MOTOR, 2HP, 1PH, 3450 RPM
1	-E1-115, -E1-230	1	3186-E1-P	MOTOR, 2HP, 1PH, 3450 RPM EXP
1	-3-230, -3-460	1	3186-3-P	MOTOR, 2HP, 3PH, 3450 RPM
1	-E3-230, -E3-460	1	3186-E3-P	MOTOR, 2HP, 3PH, 3450 RPM EXP
1	-A	1	290-A-2P	MOTOR, AIR 2HP, 56C
2	-1-115	1	3213-P	CONTROL BOX, 310-1-115
2	-E1-115	1	3217-P	CONTROL BOX, 310-E1-115
2	-1-230	1	3214-P	CONTROL BOX, 310-1-230
2	-E1-230	1	3218-P	CONTROL BOX, 310-E1-230
2	-3-230	1	3215-P	CONTROL BOX, 310-3-230
2	-E3-230	1	3219-P	CONTROL BOX, 310-E3-230
2	-3-460	1	3216-P	CONTROL BOX, 310-3-460
2	-E3-460	1	1256-P	CONTROL BOX, 456-E3 310-E3-460
3		1	07381-P	VALVE 3-4 WAY ROUND ROUND 456
4		2	41326-P	ROD, VALVE HANDLE, MONARCH
5		2	41157-P	BALL, PLASTIC, HANDLE, MONARCH
6		1	3113-P	BEARING W/ CONTROL MOUNT, 310
7		1	3280-P	CHAIN, SHUT OFF VALVE, 310
8		1	3279-P	BOLT, SHUT OFF VALVE, 310
9		1	3134-P	SAFETY LIMIT VALVE, 310
10		2	1650-P	WASHER, 5/16 SPLIT LOCK
11		2	215-P	5/16 - 18 X 5/8 HHCS GR 2
12		1	3276-P	CLEVIS PIN, TILT FRAME END 310
13		1	1277-P	CYLINDER, 2 X 10" STROKE A-BP
14		1	3275-P	CLEVIS PIN, BASE END 310
15		1	3520-P	IDLER BEARING ASM W/ CAP 310
16		4	1474-P	WASHER, 3/8 SPLIT LOCK
17		4	535-P	3/8 - 16 X 1-1/4 HHCS GR 5
18		1	M404-310-P	HYD POWER PACK, 310
	-A	1	90020-P	KIT, 3/8" FRL & VALVE

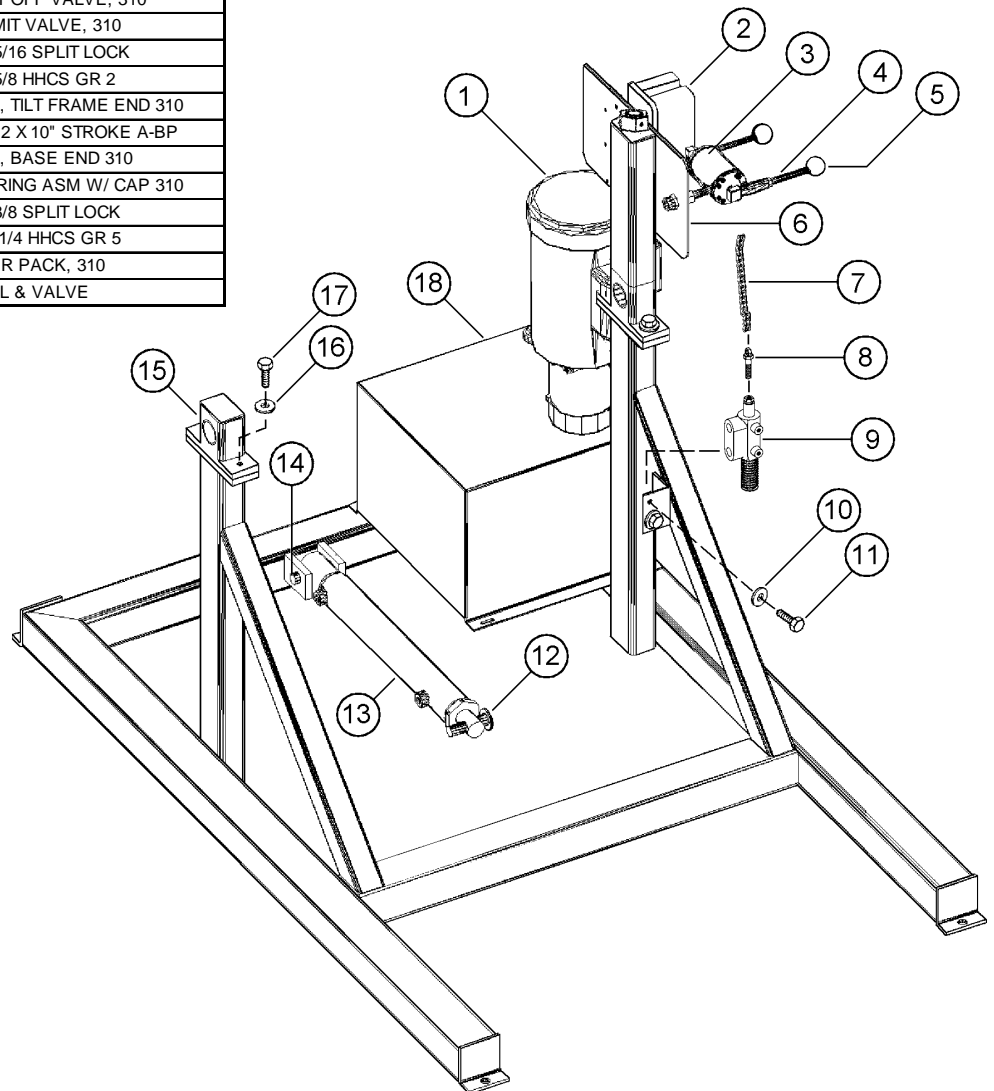

PARTS DIAGRAM FOR 310 SERIES TILT ASSEMBLY Serial # 188147 to 203638

ITEM	MODEL SUFFIX	QTY	P/N	DESCRIPTION
1		2	2654-P	BEARING, 2-15/16" PILLOW BLOCK
2		4	3318-P	3/4 - 10 X 3-1/2 HHCS GR 5
3		4	3319-P	WASHER, 3/4 SPLIT LOCK
4		4	2452-P	3/4 - 10 FIN HEX NUT
5		1	3117-P	SPROCKET, #40D, 60T, 310
6		1	3124-P	HUB, 2-15/16" KEYLESS, 310
7		1	3132-P	CHAIN, ROLLER, #40D 29 PITCHES
8		1	3127-P	SPROCKET, #40D, 20T, TAPER 310
9		1	3128-P	BUSHING, 1" TAPER LOCK, 310
10		1	3114-P	HYDRAULIC MOTOR, 310
11		1	3136-P	COUNTER BALANCE VALVE, 310
12		1	3109-P	HYD MOTOR PLATE WELD, 310
13		2	1632-P	3/8 - 16 X 7-1/2 HINGE BOLT
14		2	149-P	3/8 - 16 FIN HEX NUT
15		4	91-P	1/2 - 13 FIN HEX NUT
16		4	1657-P	3/8 - 16 X 3/4 HHCS GR 2
17		4	1474-P	WASHER, 3/8 SPLIT LOCK

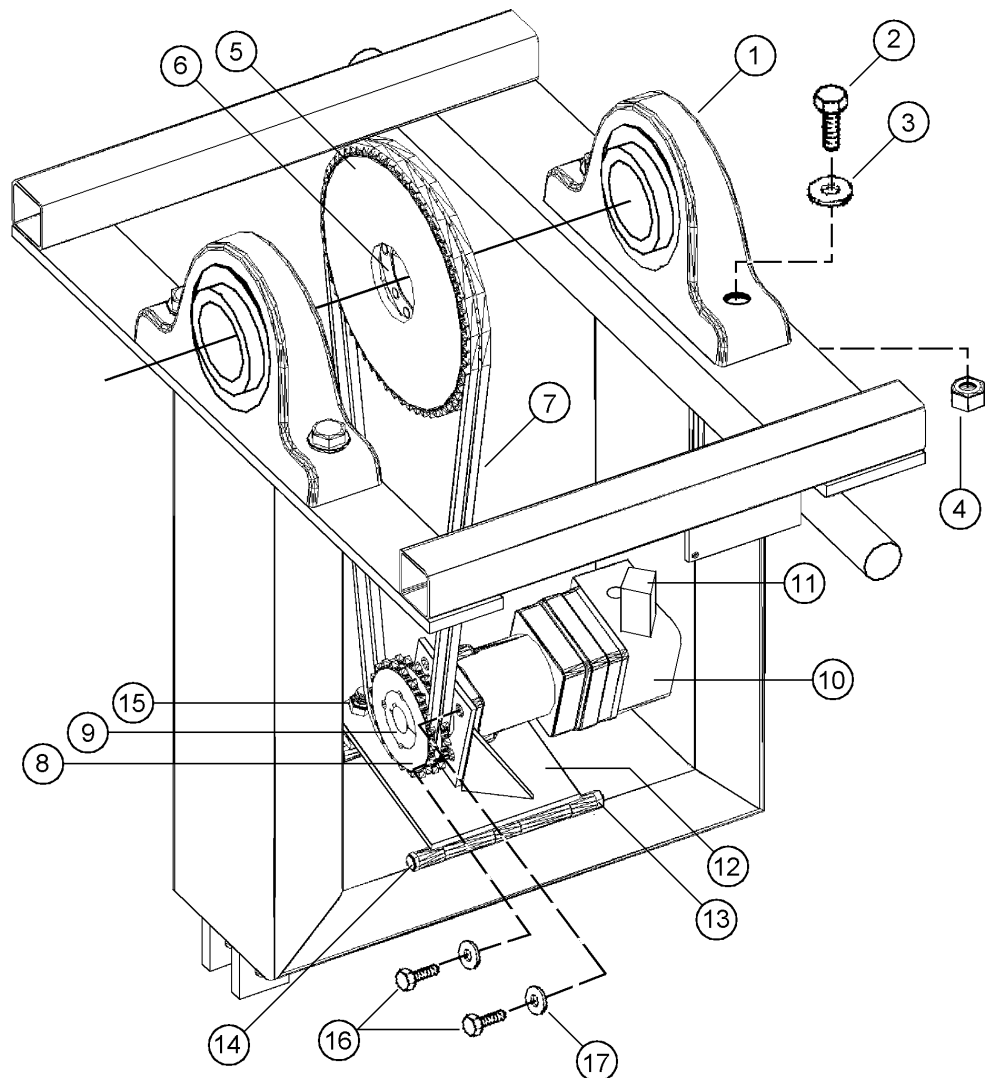

PARTS DIAGRAM FOR 310 SERIES SADDLE ASSEMBLY Serial # 188147 to 203638

ITEM	MODEL SUFFIX	QTY	P/N	DESCRIPTION
1		1	3110-P	SADDLE ASM , 310
2		1	731-P	RATCHET HINGE PLATE ONLY 1/4 A
3		2	1296-P	1/4 - 20 X 7-1/2 HHCS GR 5
4		1	3112-P	HINGE LINK WELD, 310
5		2	1297-P	1/4 - 20 REV HEX LOC NUT
6		2	22-P	3/8 - 24 x 5/8" SHCS
7		1	180-P	CHAIN, CINCH, 3/16 ALLOY 33 LK
8		1	82-P	3/8 - 16 X 2-1/4 HHCS GR 2
9		1	1169-P	3/8 - 16 REV HEX LOC NUT
10		2	3266F-P	SCREW CLAMP ASM CPT, 310
11		1	3145-P	HAND CRANK, W/ SOCKET, 310
12		1	165KIT-P	KIT, RATCHET CHAIN TIGHTENER
13		1	168-P	PAWL, WITH DRILLED HOLE
14		1	169-P	PAWL SPRING
15		1	170-P	3/8" DIA X 5/8" SHOULDER SCREW
16		1	710-P	RETAINER, RATCHET PUSH ON 3/4"
17		1	165-P	RATCHET, MALLEABLE, FOR SADDLE
18		1	136-P	HANDLE GRIP, 7/8" X 4-3/4"
19		1	726-P	RATCHET HINGE PLATE CPT 1/4" A

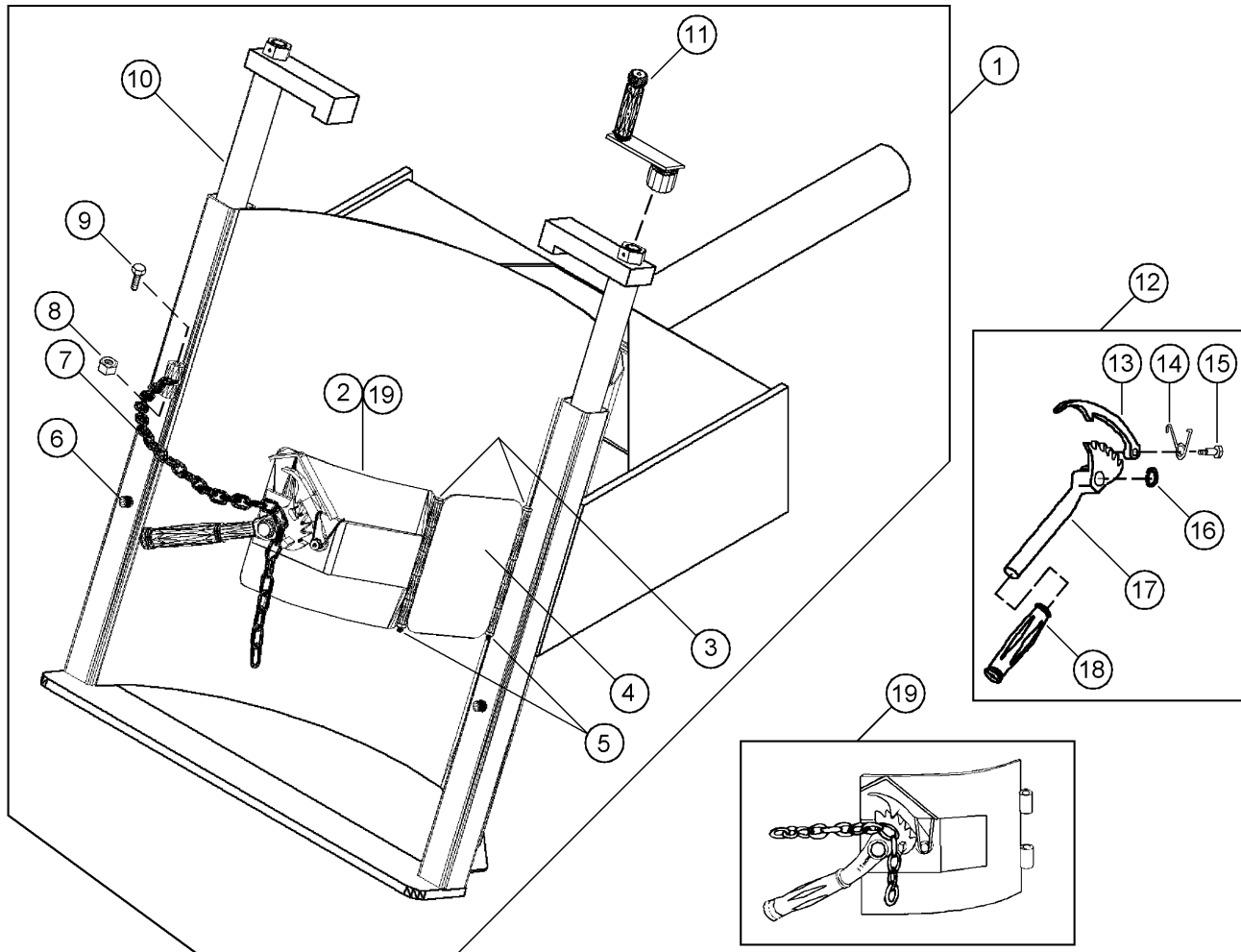

LIMITED WARRANTY

MORSE DRUM HANDLING EQUIPMENT is guaranteed against defects in workmanship or materials when used properly within its rated capacity for two years. Motors and other purchased parts carry the warranty of their manufacturers.

For Warranty claims, write for authorization to return the product prepaid, stating defect. In all instances, liability is limited to the purchase price paid and liability under the above stated warranty is limited to repairing or replacing any product which upon our examination is found to be defective.

MORSE MANUFACTURING CO., INC., East Syracuse, NY 13057

**For replacement parts, please contact your Morse dealer.
When ordering parts, please specify:**

- Part number and description,
- Model number
- Serial number

Find model number and serial number on metal name plate attached to the Tilt-To-Load Rotator.