

PailPRO™ Model 152-5

5-Gallon Pail Truck

Capacity: 150 Lb. (68 kg)

Assembly Instructions

This design requires some assembly and saves on shipping charges.

1. Slide the Base Assembly tube through the Hook Weldment (item 3) and into the Handle Assembly tube and align drilled holes.
2. Insert bolt (item 5) through the aligned holes and secure with Lock Nut (item 6) to fasten the Handle Assembly to the Base Assembly.

Note: Slide the Hook Weldment on the Base Assembly tube and tighten with T-screw at position to engage the handle of your pail.

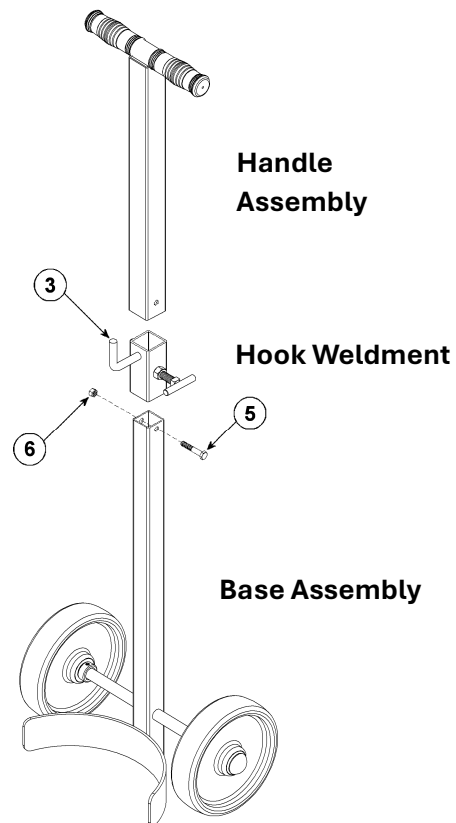

WARNING - This product can expose you to chemicals including barium sulfate, cobalt, titanium dioxide, and 2-methylimidazole, which are known to the State of California to cause cancer, and bisphenol-A, which is known to the State of California to cause birth defects or other reproductive harm. For more information go to www.P65Warnings.ca.gov

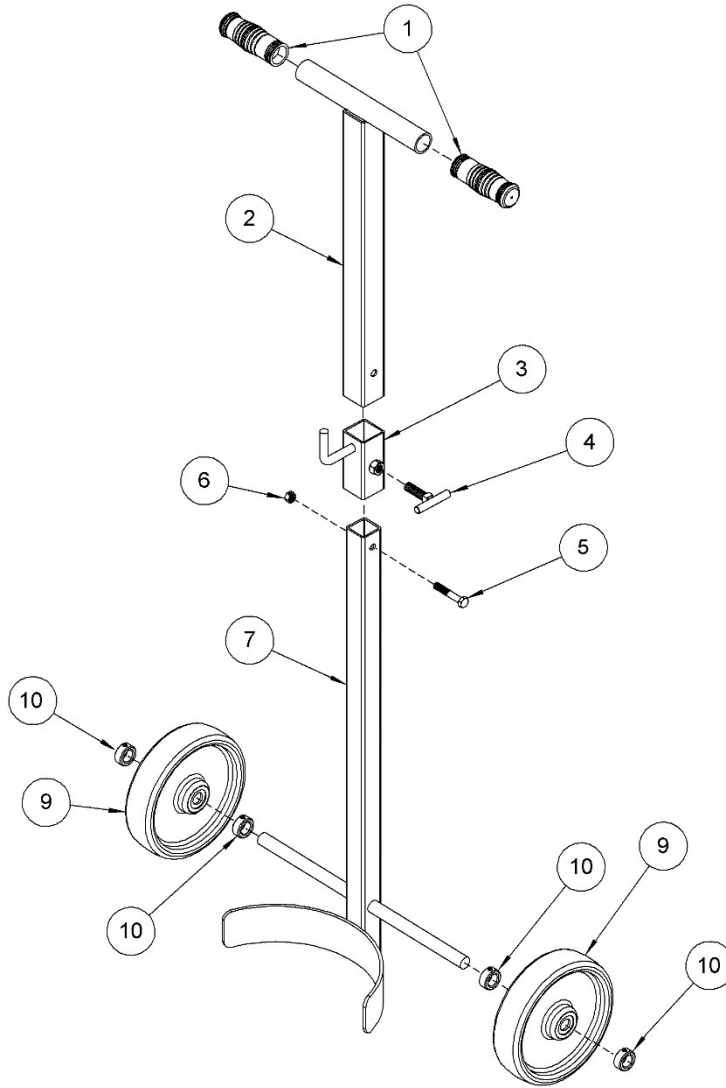

ITEM	QTY.	PART NUMBER	DESCRIPTION
1	2	83-P	GRIP, HANDLE, 1-1/4 X 4-1/2
2	1	4980-P	HANDLE WELD, 152-5
3	1	4977-P	HOOK WELD, 152-5
4	1	1372-P	TEE HANDLE, BRACKET ASM, 1-1/2
5	1	82-P	HHCS, 3/8-16 X 2-1/4 GR2
6	1	1169-P	NUT, 3/8-16 REV HEX LOCK
7	1	4973-P	FRAME WELD, PAIL TRUCK
9 *	2	87-P	WHEEL, MORTUF, 8", 3/4" BRG
10 *	4	15-P	COLLAR, 3/4" ID

* Recommended spare parts