

 MORSE

1-5154-CE SERIES

SPECIFICATIONS SHEET

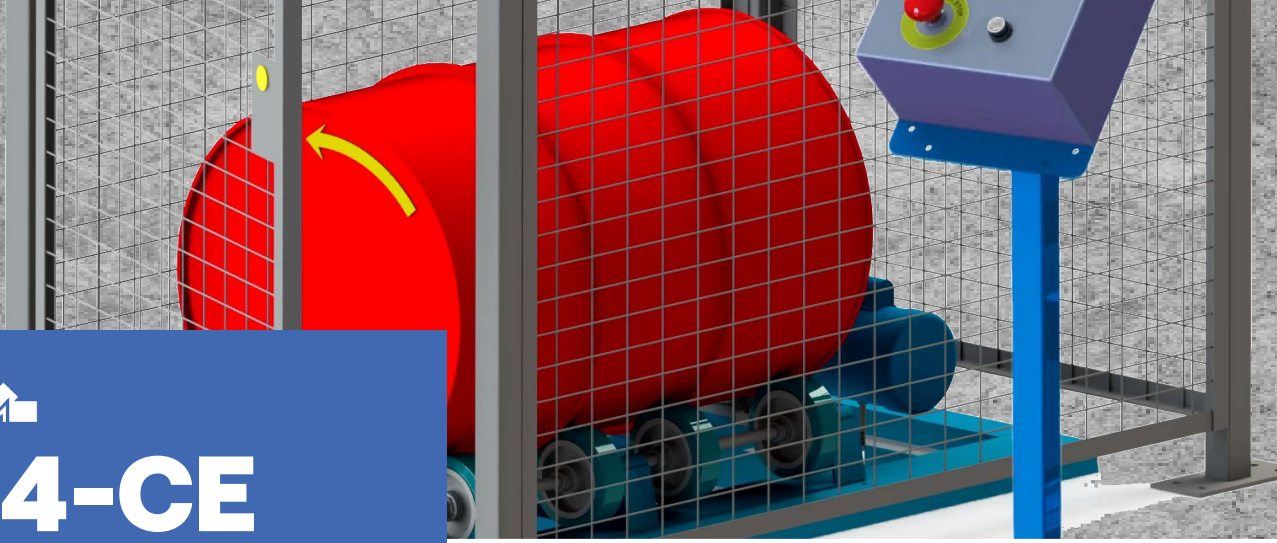

CE-MARKED DRUM ROLLERS

Drum Rollers with Controls and Enclosure with Safety Interlock.



Roll a drum on it's side to gently mix drum contents. Set duration of drum rotation anywhere from a few seconds to 16 hours.

Each Morse CE Marked Drum Roller includes Control Station and Enclosure with Safety Interlock. They are fully tested and certified compliant with European directives. Power connections and motor controls must comply with local codes.

Enclosure has integrated safety interlock in accordance with European directives. Machine automatically shuts off when the door is opened.

In case of any problem during operation, the roller can be interrupted by pressing the red emergency stop knob.

Benefits of Mixing Inside Closed Drum

- Less Hazards
- Eliminate worker exposure to dangerous ingredients
- Reduce spills and risk of contamination

Model Number	Motor	Phase	Volts	Hz	Amp Draw	Drum RPM
1-5154-1-50-CE	1/2 HP TEFC	1	220	50	2.5	16
1-5154-3-50-CE	1/2 HP TEFC	3	380	50	0.85	2 to 20



1-5154-CE SERIES CE-Marked Drum Rollers SPECIFICATIONS SHEET



Get drum into horizontal position. Shown here using Morse 4-Wheel Drum Truck model 160.



Raise horizontal drum with your hoist and a drum lifter. Shown here using Morse Drum Lifting Hook model 41.



Lower horizontal drum onto drum roller.



Position drum with ribs between roller wheels.



Close gate to engage interlock switch.



Gate has magnetic closure.

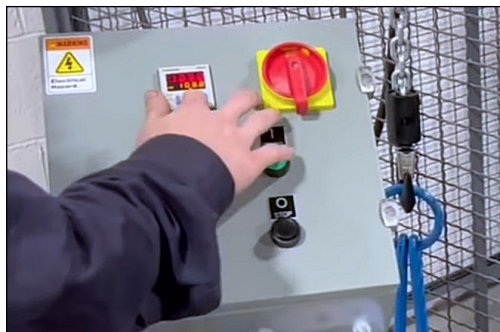

Set timer to desired drum mixing time.



Push START button to begin drum rolling.



Morse Controls include the mast and appropriate Control Box for each model. Use power controls to start and stop drum rolling.

Position control mast outside the safety enclosure on either the left or right side, or at the back of Drum Roller.

Model 1-5154-1-50-CE
Control Mast and AC Control Box
NEMA 4/12 for NON-Hazardous Areas

Control Box with:

- **FIXED** Drum Rotation at 12 RPM
- Timer adjusts from a few seconds to 16 hours
- Start and Stop Buttons
- Red Emergency Stop Button
- Lockable Main Disconnect to shut off and lock out power to the unit
- Wire terminals for external connection of safety interlock switch



Model 1-5154-3-50-CE
Control Mast and AC Control Box
NEMA 4/12 for NON-Hazardous Areas

Control Box with:

- **VARIABLE SPEED** Drum Rotation from 2 to 20 RPM
- Timer adjusts from a few seconds to 16 hours
- Start and Stop Buttons
- Red Emergency Stop Button
- Lockable Main Disconnect to shut off and lock out power to the unit
- Wire terminals for external connection of safety interlock switch





1-5154-CE SERIES

CE-Marked Drum Rollers

SPECIFICATIONS SHEET

Outside Post-to-Post Dimensions

L162.56 cm x W101.6 cm x H160.7 cm (L64" x W40" x H63.25")

Hinged Door Opening is 91.44 cm (3') Wide

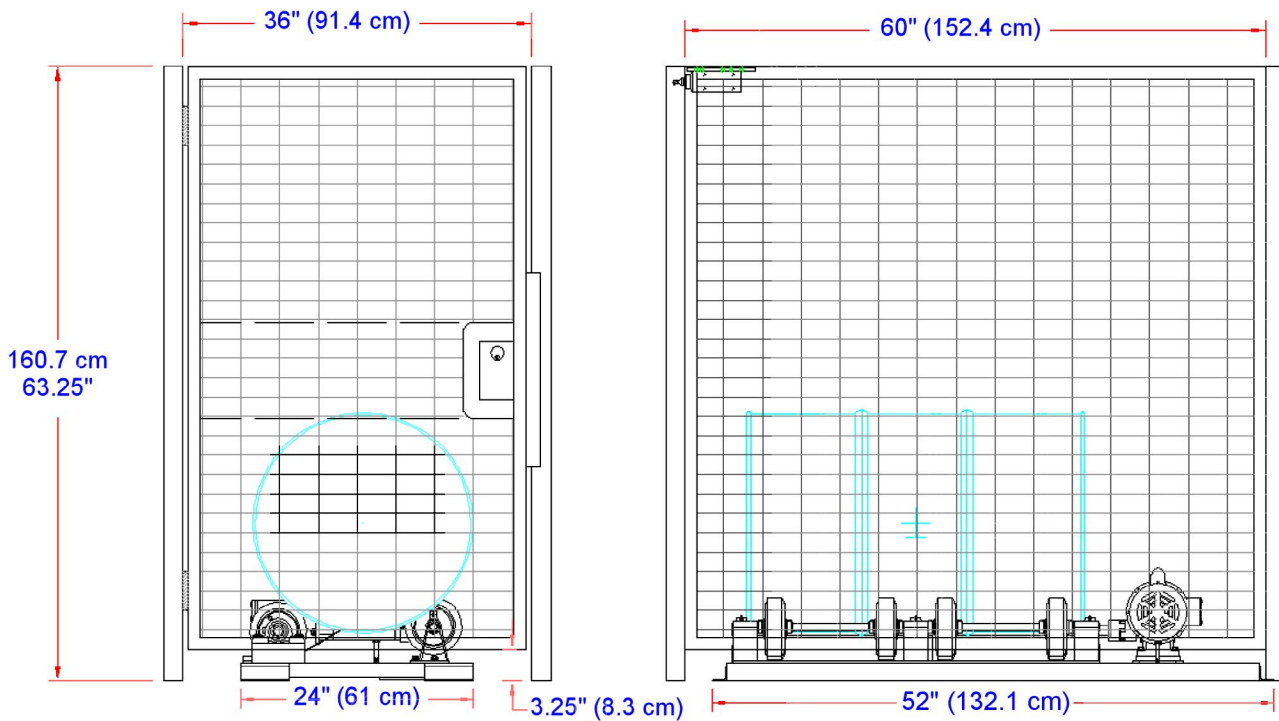
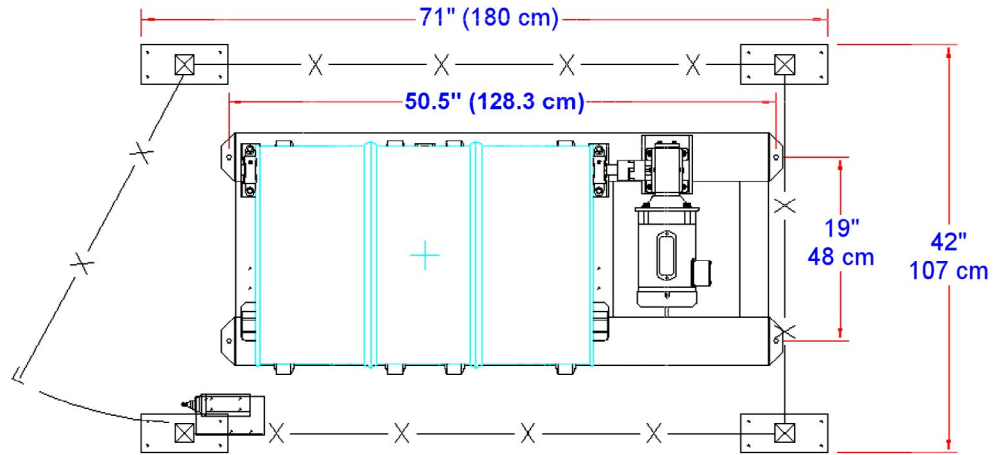

Guard Enclosure Components			
Item	Qty.	Width	Height
Wire Mesh Panel	1	91.44 cm (3' 0")	152.4 cm (5' 0")
Wire Mesh Panel	2	152.4 cm (5')	152.4 cm (5' 0")
Hinge Door	1	88.58 cm (2' 10-7/8")	152.4 cm (5' 0")
Corner Post	4	5.1 cm (2")	161 cm (5' 3.25")



Control Station Dimensions

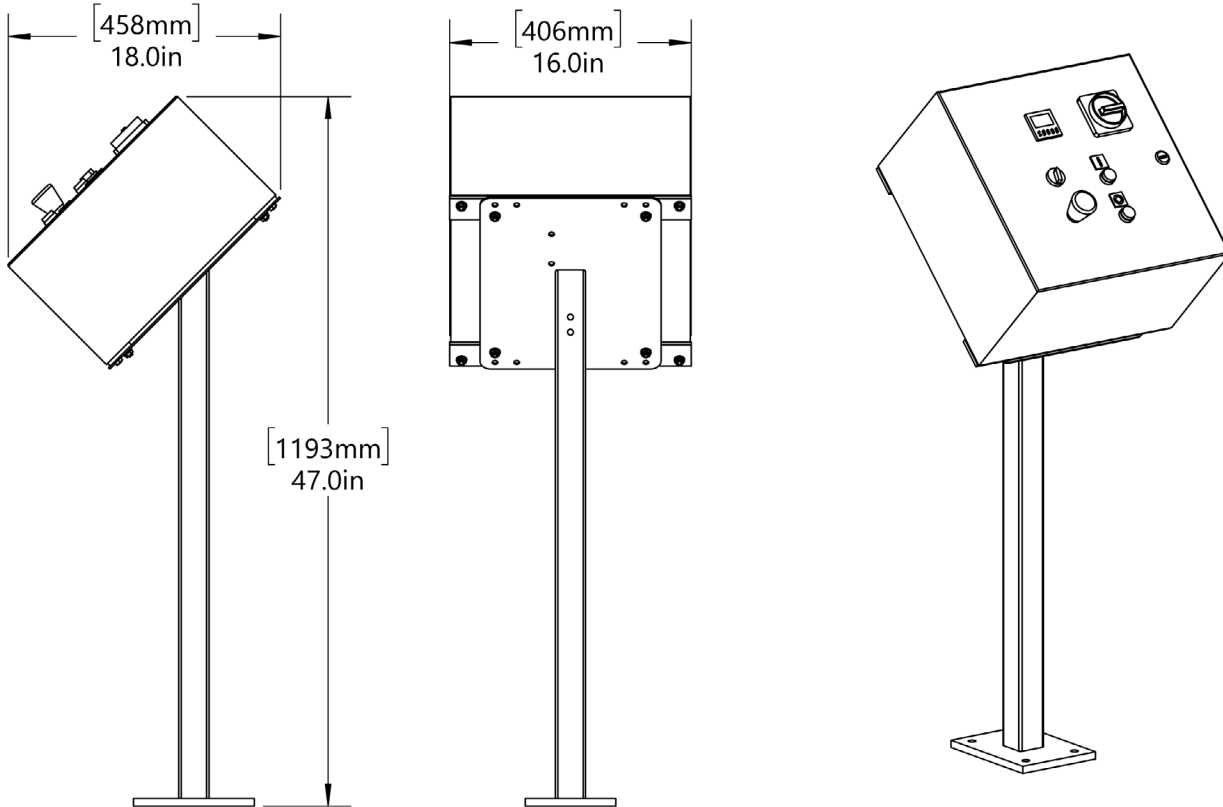



1-5154-CE SERIES

CE-Marked Drum Rollers

SPECIFICATIONS SHEET

1-5154 SPECIFICATION SHEET (CE Marked)	
Capacity: Liquid Load in drum Dry Load in drum	454 kg (1000 Lb.) 136 kg (300 Lb.)
Drum Sizes: Drum Diameter Drum Height	15 cm to 71 cm (6" to 28") Up to 102 cm (40")
Drum RPM:	Model 1-5154-1-50-CE: 16 RPM Fixed Speed Model 1-5154-3-50-CE: 2 to 20 Variable Speed
Machine Height:	30.48 cm (12")
Machine Floor Space:	132.1 cm Long x 60.96 cm Wide (52" Long x 24" Wide)
Enclosure Height:	160.66 cm (63.25")
Enclosure Floor Space:	162.56 cm Long x 101.6 cm Wide (64" Long x 40" Wide)
Shipping Weight:	376.5 kg (830 Lb.)
AC Motor Specs for Model 1-5154-1-50-CE 1/2 HP 1PH 1450 RPM 50HZ 56C TEFC	VOLTS (AMP DRAW) 220V (2.5 Amps)
AC Motor Specs for Model 1-5154-3-50-CE 1/2 HP 3PH 1425 RPM 50HZ 56C TEFC	VOLTS (AMP DRAW) 380V (0.85 Amps)