

CONTENTS

	Page
Receiving Procedures.	1
Warranty.	1
Safety Information.	1 - 2
Machine Description.	2
Options.	2
Controls.	3
Operating Instructions.	4 - 5
Maintenance.	5

Operator’s Manual
for Morse Omni-Lift Karrier
with Spark Resistant Parts
Model 405M

Serial Number 0617 to ____ (MMYY)

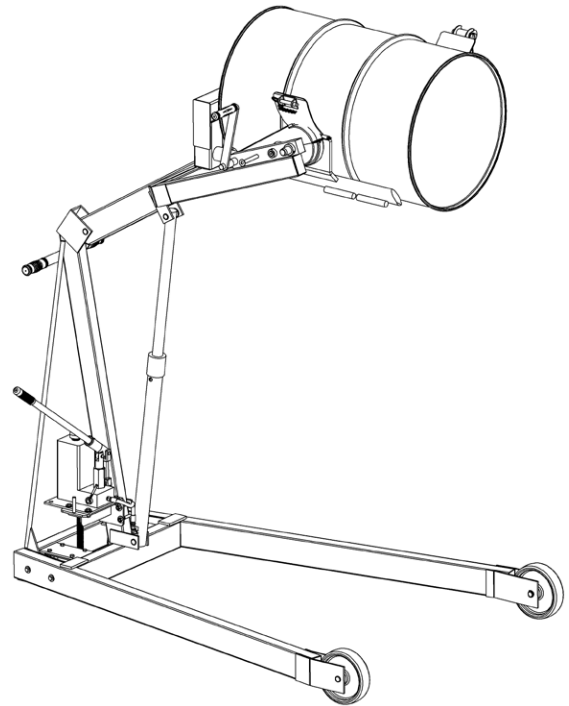

Receiving Procedures

Every Morse drum handler is inspected prior to shipping. However, damage may be incurred during transit.

- Check for visible damage. If you choose to accept damaged freight, always sign noting the damage on the **Bill of Lading**.
- Document the damage and have the truck driver sign. We recommend keeping a digital camera at your receiving dock for this purpose.
- Open packages expeditiously to check the condition of the goods. There is only a 24 hour window to notify the carrier of any concealed damage.
- Immediately **report all damage to the shipping company!** Then you may contact Morse for assistance with your freight claim.
- Morse Manufacturing will not be held responsible for any damaged freight that is not signed for as damaged.

Limited 2 Year Warranty

Morse drum handling equipment is guaranteed against defects in workmanship or materials for two years when used properly within its rated capacity. Warranty does not cover wear from normal use or damage from accident or abuse. Motors and other purchased parts carry the warranties of their manufacturers.

For warranty claims, contact your Morse Dealer to obtain a return authorization number, and for return freight advice. Return freight must be prepaid.

In all instances, liability is limited to the purchase price paid or to repairing or replacing the product. Customer assumes liability for any modifications, unauthorized repairs or parts substitution.

Safety Information

While Morse Manufacturing Co. drum handling equipment is engineered for safety and efficiency, a high degree of responsibility must be placed upon the machine operator to follow safe practices, based primarily on common sense, upon which true safety depends.

Failure to follow the safety precautions in this manual can result in personal injury or property damage. Observe the same precautions as with similar machinery where carelessness in operating or maintenance is hazardous to personnel. Carefully read the safety precautions below and throughout this manual.

Review the Material Safety Data Sheet(s) for the material(s) in the drum(s) and take all necessary precautions. Safety shoes, work gloves, hard hat and other personal protective devices are recommended.

Prior to initial use, inspect all moving parts and test rotation of drum holder assembly. Inspect drum holder assembly for proper operation. Perform necessary load test, inspections, operator training, etc.

Operator's Manual for Morse Omni-Lift Karrier Model 405M
Serial Number 0617 to ____ (MMYY)

Safety Information (continued)

 **DANGER** - Indicates a situation which, if not avoided, will result in serious injury or death. This signal word is limited to the most extreme situations.

 **WARNING** - Indicates a situation which, if not avoided, could result in serious injury or death.

 **CAUTION** - Indicates a situation which, if not avoided, can result in damage to the machine.



CAUTION – Do Not Transport with Drum Raised. Always lower the drum holder to lowest position before transporting.



WARNING - The Omni-Lift Karrier is designed to handle one drum of the types listed below. Machine Description. DO NOT attempt to handle any other type of drum or object. DO NOT exceed the weight capacity of 800 Lb. (363 kg).

MORSE
Mfg. Co., Inc.
E. Syracuse, NY

The Specialist
In Drum
Handling
Equipment

800 Lb.
(363 kg)
Max. Capacity

Made in U.S.A.



WARNING - Do Not Modify the Unit. Under no circumstances should any modifications be made to the Morse machinery without factory authorization. Any modifications may void the warranty. This machine was designed to perform a specific job and alterations may result in injury to operator or machine.



WARNING - No Loose Fitting Clothing. Wear close-fitting clothing and safety equipment appropriate to the job. Loose fitting clothing may become caught on the machinery and cause severe personal injury.



CAUTION - Wear safety shoes with non-slip soles and hard toe protection.



CAUTION: DO NOT allow drum to impact on floor, ground, or dumping station, etc.



WARNING: This product can expose you to chemicals including barium sulfate, cobalt, titanium dioxide, and 2-methylimidazole, which are known to the State of California to cause cancer, and bisphenol-A, which is known to the State of California to cause birth defects or other reproductive harm. For more information go to www.P65Warnings.ca.gov

Machine Description

The Omni-Lift Karrier is designed to lift, transport, and rack a ribbed 55-gallon (210 liter) steel drum 22.5" (56 cm) in diameter. The maximum full-drum capacity is 800 Lb. (363 kg). The capacity is derated to 500 Lb. (227 kg) for a half-full drum. The half-full rating is based on the tilt mechanism's capacity for handling an unbalanced bottom-heavy drum.

Operator's Manual for Morse Omni-Lift Karrier Model 405M
Serial Number 0617 to ____ (MMYY)

Important

1. Review the Material Safety Data Sheet(s) for the material(s) in the drum(s) and take all necessary precautions. Safety shoes, work gloves, hard hat and other personal protective devices are recommended.
2. Please read all instructions thoroughly before attempting to operate your new Morse drum handler.
3. The Omni-Lift Karrier has a maximum capacity rating of 800 Lb. (363 kg) full drum and 500 Lb. (227 kg) half-full drum and is designed to lift, move and pour a 55-gallon (210 liter) steel drum. DO NOT exceed these ratings. Exceeding these ratings or handling drums other than those mentioned above is unsafe and could result in equipment damage, excessive wear or awkward handling.
4. Omni-Lift Karrier are intended for lifting, moving, and holding drums for tilting, pouring or racking. Drums may be lifted upright to or from the floor or other suitable surface on dollies, scales, etc.
5. When loading, unloading, operating, or maintaining your Morse drum handler, always use care and good judgment. Maintain secure footing and a firm hold. Keep hands and loose clothing away from all moving parts. Never allow anyone to be below any part of a raised drum handler or drum. Read operating instructions and review the pictures in the sales brochure before operation.
6. Prior to initial use, inspect all moving parts and test rotation of drum holder assembly. Inspect drum holder assembly for proper operation. Perform necessary load test, inspections, operator training, etc.

Controls

The Morse Hydra-Lift Karrier is manually propelled and steered.

There are two functions for the operator to control (Figure 3.0):

1. "LIFT" and Lower function for vertical positioning of the drum
2. "TILT" function to control the degree of rotation of the drum

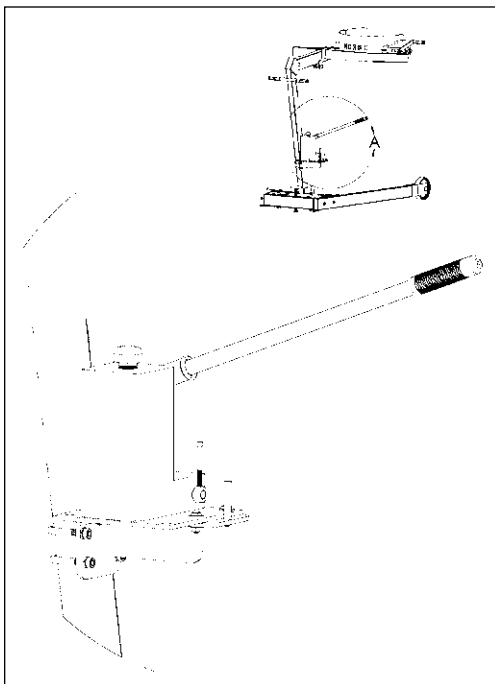

Figure 3.0

LIFT and Lower Function

To raise the drum

1. Insert pump lever handle into pump socket.
2. With the release valve closed, begin to pump the lever handle. The drum will lift.

To lower the drum

1. Open the release valve slowly, a part of a turn. Allow the drum to descend at a controlled rate. The valve may be reclosed to hold the drum at any height.

2. TILT Function to turn the drum

- Turn the hand crank to turn the drum.
- Before releasing your grip on the hand crank, pull out the stop pin to block the hand crank from spinning freely.
- If the drum handler is equipped with the MORStop Tilt-Brake, there is no need to use the stop pin. Braking is immediate and self-actuating, without additional steps by the operator.

NOTE: To add the MORStop Tilt-Brake to your drum handler, order part # 3900-P for a field installation kit.

Floor Lock

The screw-down floor lock is located on the base of the tower. Turning the floor lock clockwise until it locks in the down position activates the floor lock. When the floor lock is activated it prevents unwanted free wheeling of the unit. Floor conditions determine the effectiveness of the floor lock. The operator should verify its holding action before depending on it to hold.

Operator's Manual for Morse Omni-Lift Karrier Model 405M
Serial Number 0617 to ____ (MMYY)

Operating Instructions

**To Lift an Upright Drum from the Floor
and Place Horizontally in a Drum Rack**

1. Roll the Omni-Lift Karrier to the drum.
2. Tilt the drum holder assembly down into the vertical position with the cross bar on top.
3. Swing open ratchet hinge plate and push the Omni-Lift Karrier toward the drum, until the two parallel drum-supporting bars are firmly resting against the side of the drum.
4. Lower the drum holder assembly until the bridge meets the top of the drum. In this position, the top rim chine hooks should be an inch or two below the top drum rim.
5. Secure the drum: Drape the web strap across the face of the drum.
 - Place strap loop between clevis and secure with pin.
 - Operate ratchet to tighten strap around drum.
 - Ensure that the chine catches on the two parallel drum-supporting bars are immediately under the top rim of the drum
6. Raise the drum: Pump the lever handle to raise the drum only until the drum is 6" to 12" (15 to 30 cm) clear of the floor.
7. Move the Omni-Lift with the drum to the racking area. NOTE: TRANSPORT THE DRUM UPRIGHT AT A HEIGHT JUST CLEAR OF THE FLOOR. DO NOT ALLOW THE DRUM TO IMPACT ON FLOOR, RACKING STATION, ETC. OR A SPILL OR DAMAGE COULD OCCUR.
8. Raise the drum to racking height with hand pump.
9. Rotate drum to horizontal position for racking using the hand crank. Note: Before releasing your grip on the hand crank, pull out the crank stop pin to block the crank from spinning freely.
10. Disconnect the web strap with drum in horizontal position.
11. Place drum into rack: Push the Omni-Lift to the drum storage area and raise or lower the drum to a height that is a couple inches higher than the shelf height. Push the Omni-Lift into the storage position and carefully lower the drum onto the rack. The two parallel drum-supporting bars should be just below the sidewall of the drum but still above the rack. This will allow clearance to withdraw the Omni-Lift and leave the drum in the storage position.

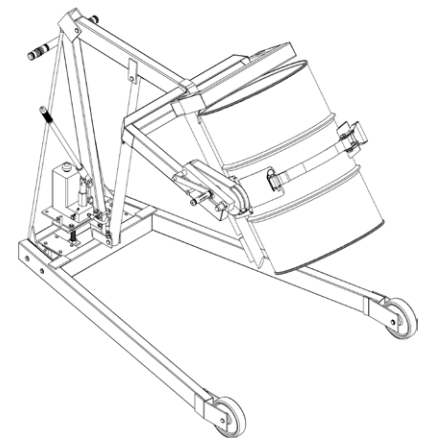
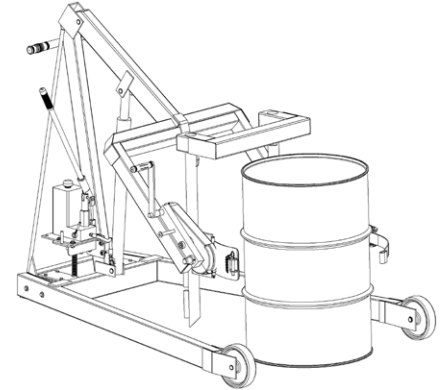

To Take a Horizontal Drum from a Rack and Place Upright on the Floor

1. Tilt the drum holder assembly to the horizontal position and swing both hinged bands to the open position. Raise the drum holder assembly to the approximate elevation of the drum to be taken down.
2. Push the Omni-Lift close to the drum in the rack and, if necessary, adjust the height of the drum grab to clear the drum walls and rack. Then roll the Omni-Lift forward until the "bridge" meets the head of the drum.



DANGER - It is CRITICAL that the bridge of the drum holder assembly is fully pressed against the top of the drum before lifting from the horizontal position. If the top of the drum is not seated against the bridge, the chine catches may not properly engage and the drum can slide off.

The true safety of this operation, depends on the operator correctly positioning the drum in the drum holder, and verifying proper engagement of the chine catches.

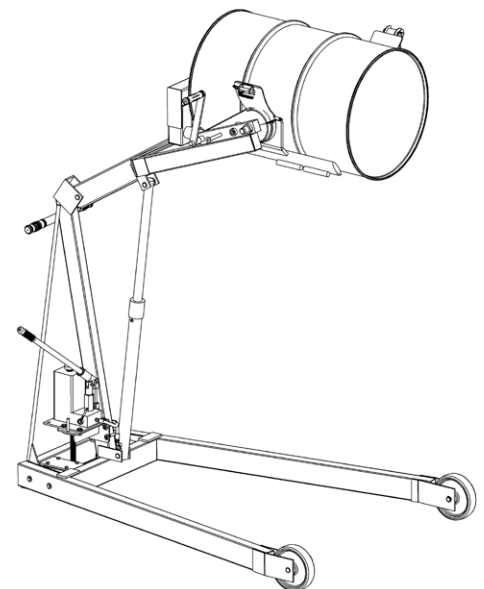

Operator's Manual for Morse Omni-Lift Karrier Model 405M
Serial Number 0617 to ____ (MMYY)

3. Raise the horizontal drum from the rack a few inches and back the Omni-Lift away.
4. Lower the horizontal drum to about 48" (122 cm) from the floor.
 - Hand Pump: To lower the drum with the hand pump, open release valve slowly, a part of a turn. Allow the drum to descend at a controlled rate. The valve may be reclosed to hold the drum at any height.
 - Power Lift: To lower the drum with the power lift, lower the control valve.
5. Secure drum BEFORE tilting by operating ratchet to tighten strap around drum. Ensure that the chine catches are immediately under the top rim of the drum..
6. Carefully tilt the drum to the vertical position.
7. Lower the upright drum to the floor.
8. Release upright drum: When the weight of the drum is entirely on the floor, squeeze the ratchet release lever and open all the way to unlock. Then release the tension on the strap. Allow enough slack in the strap in order to remove strap loop from clevis. Swing both hinged bands to the open position.
9. Raise the drum holder assembly about 12" (30 cm).
10. Pull the Omni-Lift back to clear the drum.
11. Store unit with drum holder assembly in the horizontal position and lowered near the floor.

Maintenance

- Periodic inspection for the general condition of structural and mechanical components is imperative for safe and efficient operation.
- Periodically inspect all moving parts, framework, and contact areas for signs of wear, fatigue, or loosening. Tighten, adjust, or replace parts as necessary to prevent failure and maintain proper function.
- Inspect the hydraulic system for oil drips, hose damage, or other signs of wear. Inspect the level and condition of the hydraulic fluid. Replace any parts that show signs of wear.
- Grease wheel bearings periodically. Oil or grease all moving parts including: the three clevis pins and the surfaces of the boom which contact the inside of the mast cap, the hinge pin, the gears and sprockets in the tilt drive, and the ratchet and pawl.
- Worn or damaged parts must be properly replaced with the correct, genuine Morse parts.
- Hydraulic pump should be filled with the provided quart of Mobil ATF D/M (Morse part # 3983-P). Material safety data sheet (MSDS) is available online. Change oil yearly, sooner depending on dirty conditions or outdoor use.

Parts Information

Worn or damaged parts must be properly replaced with the correct, genuine Morse parts.