

CONTENTS

| | Page |
|------------------------------------|------|
| Parts List and Diagram. | 1 |
| Installation Instructions. | 1 |
| Operating Instructions. | 2 |

Operator's Manual
for Morse Rim Clamp Assembly Kit
with Spark Resistant Parts

Kit # 4560M-P
Serial number 0616 to ____ (MMYY)

IMPORTANT NOTE

4-Digit serial numbers are simply the month & year of manufacture
Example: 0802 is August 2002

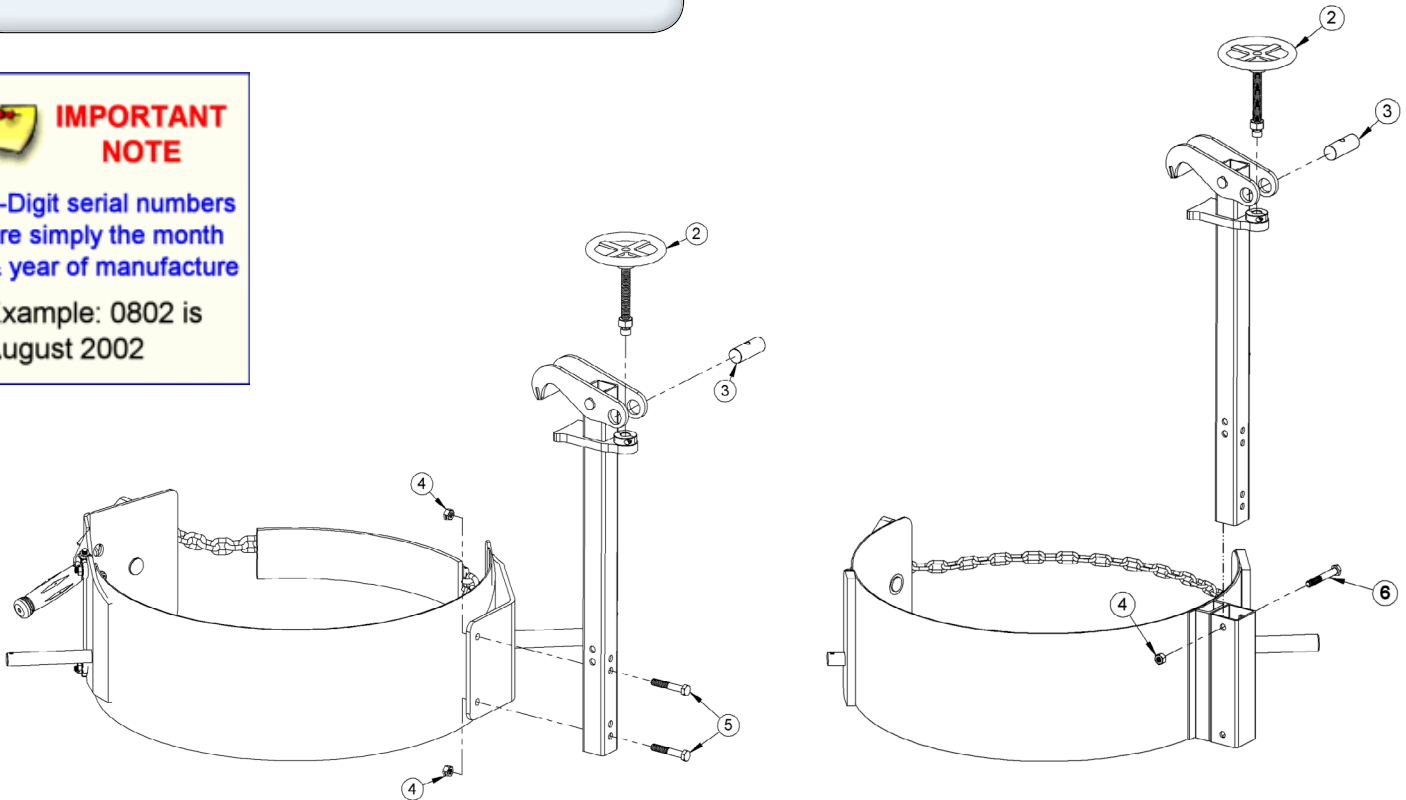

INSTALLATION INSTRUCTIONS
for MORCINCH™ Drum Holder

1. Position Rim Clamp Assembly (item 1) on drum holder bracket with holes aligned.
2. Bolt in place using 2 bolts (item 5) and 2 nuts (item 4).

INSTALLATION INSTRUCTIONS
for Drum Holder with Socket Tube

1. Slide Rim Clamp Assembly (item 1) down through socket tube, and line up top holes in Rim Clamp Assembly with top holes of socket tube.
2. Use bolt (item 6) and nut (item 4) to bolt in place through the top holes of the socket tube and the Rim Clamp Assembly.

| ITEM | QTY | PART # | DESCRIPTION |
|------|-----|--------|--------------------------------|
| 2 | 1 | 3616-P | HANDWHEEL ASM, 4", 3540-P 185R |
| 3 | 1 | 3510-P | THREADED BARREL, RIM CLAMP |
| 4 | 2 | 1169-P | NUT, 3/8-16 REV HEX LOCK |
| 5 | 2 | 82-P | HHCS, 3/8-16 X 2-1/4 GR2 |
| 6 | 1 | 1315-P | HHCS, 3/8-16 X 2-3/4 GR2 |

Operator's Manual for Morse Rim Clamp Assembly Kit with Spark Resistant Parts
Part # 4560M-P
Serial Number 0616 to ____ (MMYY)

OPERATING INSTRUCTIONS

TO SECURE DRUM:

1. Turn hand wheel (item 2) counter clockwise to open top jaw.
2. Position drum holder assembly with bottom jaw of rim clamp directly under top rim of drum.
3. Turn hand wheel clockwise until top jaw is pressing tightly against top of drum (see Figure 1).
4. Secure drum with chain and ratchet mechanism. Drum is now ready to be lifted and tilted.

TO RELEASE DRUM:

1. Lower drum to floor in an upright position.
2. Release chain from ratchet mechanism by applying pressure to ratchet handle in a clockwise direction with one hand and opening pawl to free ratchet with other hand. Remove chain link from ratchet.
3. Open rim clamp by turning hand wheel counter clockwise.

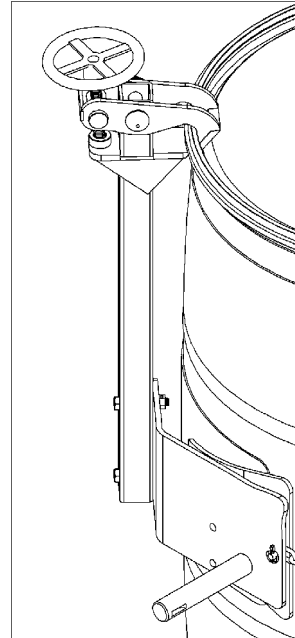

Figure 1
Plastic drum being lifted with Rim Clamp Assembly Kit installed.



WARNING: This product can expose you to chemicals including barium sulfate, cobalt, titanium dioxide, and 2-methylimidazole, which are known to the State of California to cause cancer, and bisphenol-A, which is known to the State of California to cause birth defects or other reproductive harm.
For more information go to www.P65Warnings.ca.gov