

Mix Contents of Closed Steel Drum

- Use common steel drum for mixing
- No permanent container to purge between batches
- Use separate drum for each batch

Agitate your drum's contents without even opening the drum! Incorporate important stratified ingredients and eliminate sediment in the bottom of your drum. Mixing in closed drums eliminates the hazards, worker exposure, and messy cleanup associated with insertion mixers.

This compact, portable mixer and drum cradle rolls a closed drum to agitate the contents. You may also dispense directly from your drum through a faucet. The built-in tipping bar provides leverage to ease loading and unloading. The sides and back are enclosed to protect the drive.

Drum Sizes

- Roll a 6" to 28" (15.2 to 71 cm) diameter drum
- Up to 38" (97 cm) tall. Relocate wheels to accommodate various steel drum sizes.
- The tipping lever will ONLY engage a drum 30" (76.2 cm) or taller

Drum RPM

- Fixed speed models roll a 22.5" (57.2 cm) diameter drum at 20 RPM (16 RPM on 50Hz models)
- Variable speed models roll a drum from 15 to 24 RPM (13 to 20 RPM on 50Hz models)

Capacity of Wheeled Models

- Liquid load: 500 Lb. (227 kg)
- Dry load 300 Lb. (136 kg)

Maximum ambient operating temperature

- 140° F (60° C)

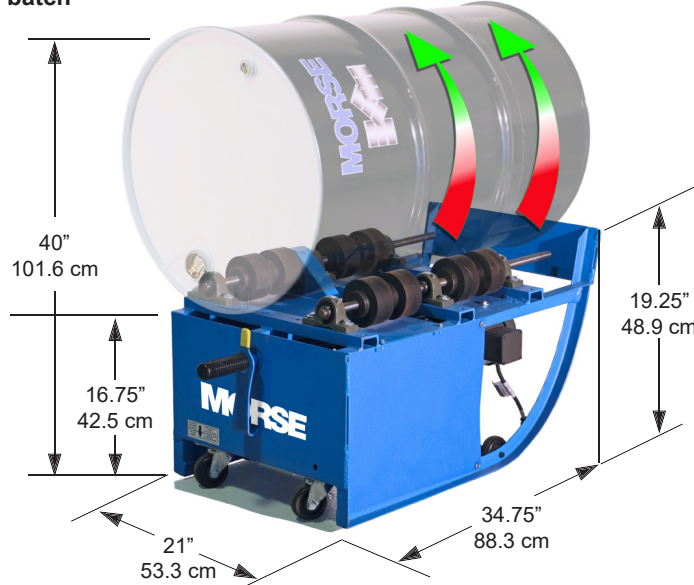

Kick Stand

Deploy Kick Stand to support drum roller in upright position.

Dispense Directly from Drum



Drain the contents of a drum directly into a smaller container for use as needed. A closed faucet can be in place while the drum is rotated.

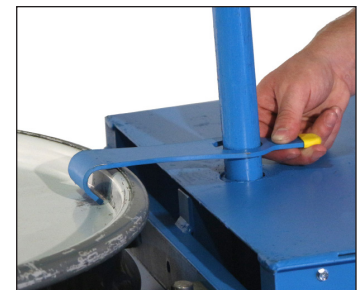

Top Rim Hook

Engage Top Rim Hook to help in tipping it over into rolling position.

Options and Accessories

**Roll a 1 to 5 Gallon Can
Kit # 1-5P**

Install this Idrer Attachment kit to extend the usefulness of your drum roller. Easily attached with 4 bolts, the spacers adjust to roll a 1 to 5 gallon (4 to 20 liter) cylindrical can. Rolls a 5-gallon (20L) can at approximately double the RPM of a 55-gallon (210L) drum.

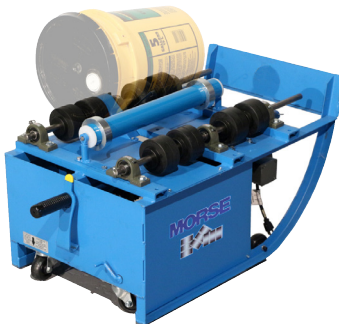

**Roll a Plastic Drum
Option # POLY-201**

Factory installed option to roll a plastic drum on portable drum roller.

- Extra wheels to support flexible soft-sided plastic drum
- End stop to prevent drum from traveling
- Chain to assist in pulling upright drum over into rolling position

POLY-201 is **NOT** a drum roller by itself.

Adds 62 Lb. (28.1 kg) to the ship weight and requires a skid.

Kit # POLY-201FI

Kit for customer to install on wheeled 201 Series drum roller.



Simple Rock-Over Loading

Built-in tipping lever facilitates loading. Frame shape and height make loading easier. Note: Tipping lever only engages drum 30" (76.2 cm) or taller.

Internal Components

Large sprockets and roller chain for years of reliable drum rolling.

Custom Stainless Steel Portable Drum Rollers

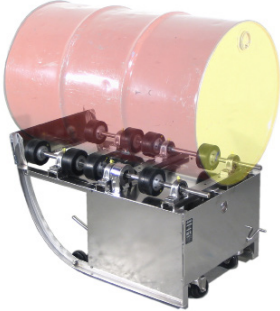

Custom versions made of type 304 stainless steel are valuable for use in clean environments such as food and pharmaceutical companies.

Belted Drum Rollers Only for FIBER Drum

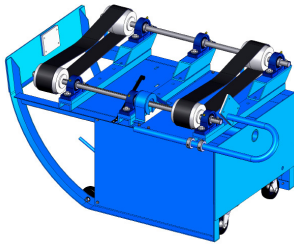

Belted portable drum rollers are designed to roll a fiber drum, and can also be used for a steel drum. They have broad belts, instead of the wheels, to support your drum.

Capacity of Belted Models: 300 Lb. (136 kg)

Construction and Design Features

Bottom shows working parts and their accessibility

1. Built-in tipping lever extends to assist in loading drum
2. Chine hook
3. Variable speed control
4. Two 3" (7.6 cm) swivel casters for mobility.
5. Bearings support two jack shafts.
6. Standard motor is 1/2 HP, 60Hz, 115V, 1800 RPM, single phase, ball-bearing, totally enclosed type with manual reset overload protection, switch, cord and plug. Air motors and other electric motor voltages and types are available without protection, switch, cord or plug.
7. Two 3" (7.6 cm) polyolefin wheels
8. Single-phase AC models have 8" (20.3 cm) long cord and 3-prong plug
9. Kick stand supports unit when standing on end
10. Base plate
11. Kick stand release handle

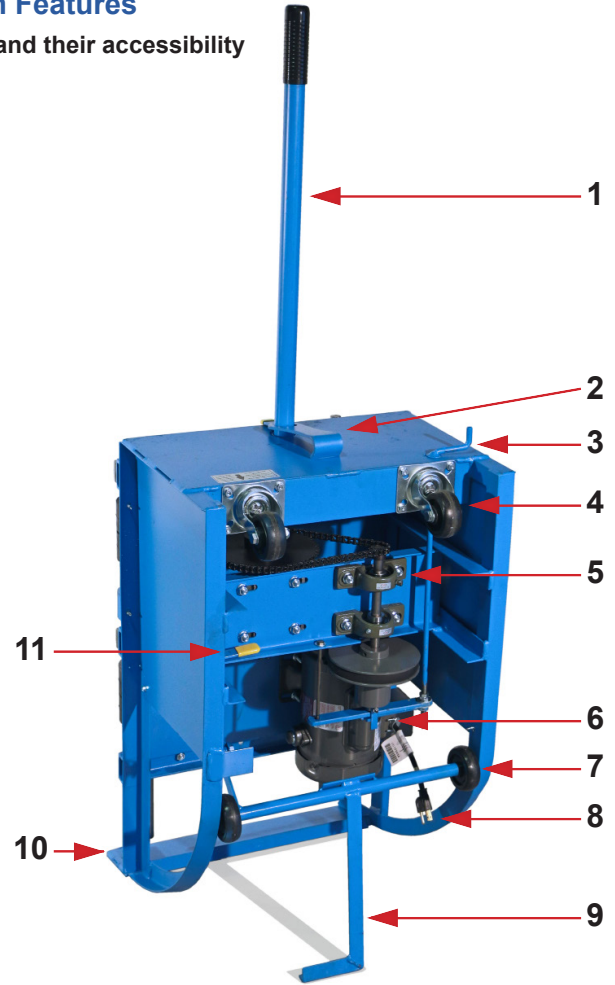

Model # 201VS-1 shown

Steps To Use Portable Drum Roller

A. Extend tipping lever (1) and tilt drum roller to upright

B. Activate kickstand (9) by pulling with foot toward you until locked so drum roller stands by itself

C. Load drum onto base plate (10) with drum truck (model # 160 shown) or below-hook drum lifter

...continued on page 3



Steps To Use Morse Portable Drum Rollers (continued from page 2)

D. Extend tipping lever (1) fully and push toward drum. Engage chine hook (2) on top rim of drum

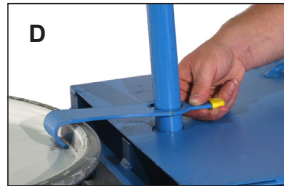

E. To raise kickstand (9), push tipping lever (1) toward drum to allow kick stand to clear the floor. Then pull yellow release handle (11)



F. Pull fully extended tipping lever (1) to tilt drum roller over to horizontal rolling position



G. Move drum roller into enclosure with interlock, connect power (8) and turn on

H. Once rolling is complete, turn off drum roller, disconnect power (8) and remove drum roller from enclosure

I. Extend tipping lever (1) and engage chine hook (2) on top rim of drum



J. Tilt drum roller back to upright and pull kickstand (9) with foot to support drum roller in upright position

K. Remove upright drum with drum truck or below-hook drum lifter

Mixing times vary depending on factors such as...

- Drum RPM
- Drum size
- Fullness of drum (clearance space within drum)
- Liquid vs powder or granulated drum contents
- Degree of uniformity / homogeneity required
- Ambient temperature

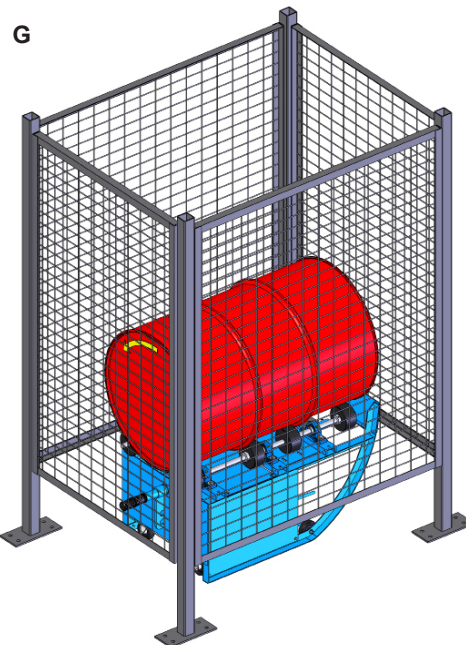

Guard Enclosure Kits with Safety Interlock

Comply with OSHA Requirements
(Drum Roller Sold Separately)

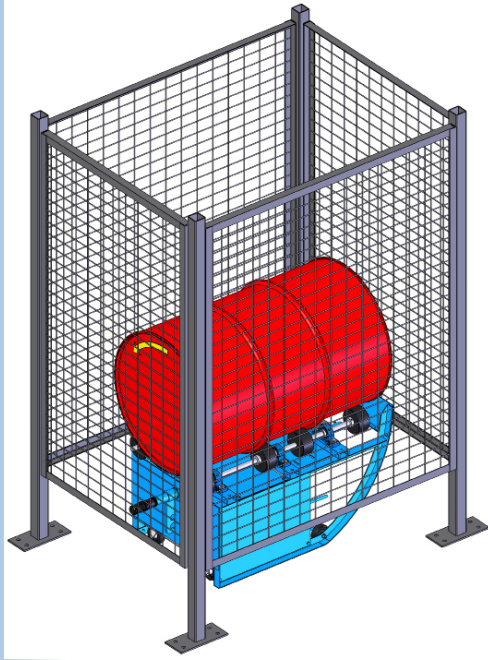

Outside Post-To-Post Dimensions
L52" x W40" x H63.25" (132 x 102 x 161 cm)
3' (91.4 cm) WIDE DOOR OPENING

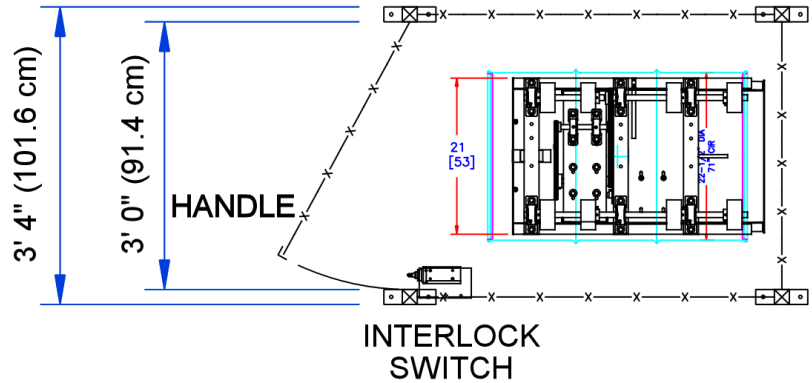

DOOR PANEL

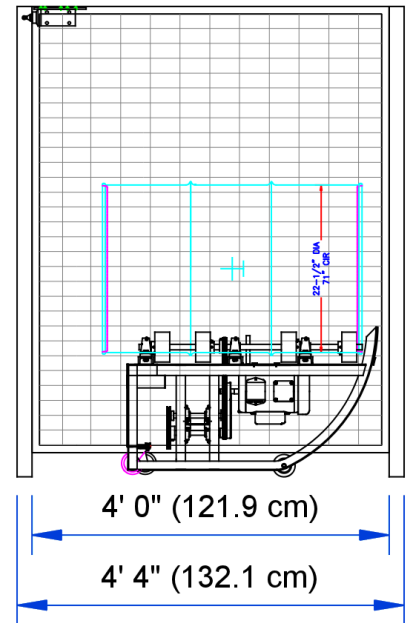
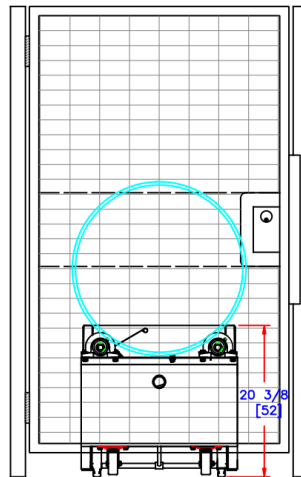
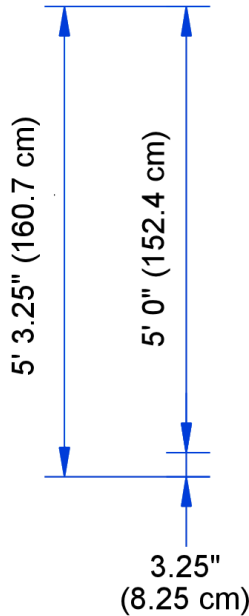

Enclosures for Morse Portable Drum Rollers have a safety interlock to automatically shut off the drum roller when the gate is opened. Open the enclosure gate, place your drum onto the drum roller, then close the gate to allow operation. Connections are included for single-phase AC and for air powered models only. Customer to provide controls and connections for 3-phase AC and for explosion-proof AC models.

Install all Morse Drum Rotators in accordance with OSHA requirements for enclosure and safety interlock, etc. Drum roller automatically turns off when enclosure door is opened.

For OSHA compliance, see OSHA subpart O.1910.212(a)(4) "Barrels, containers, and drums. Revolving drums, barrels, and containers shall be guarded by an enclosure which is interlocked with the drive mechanism, so that the barrel, drum, or container cannot revolve unless the guard enclosure is in place."

Power connections and motor controls must comply with applicable codes.

Guard Enclosure Kit	Guard Enclosure Kit with Safety Interlock	Gate Switch
GEK-201-1	Fits Portable Drum Roller with 1-phase electric motor	AC
GEK-201-3	Fits Portable Drum Roller with 3-phase electric motor	AC
GEK-201-E1	Fits Portable Drum Roller with Explosion-proof 1-phase electric motor	AC
GEK-201-E3	Fits Portable Drum Roller with Explosion-proof 3-phase electric motor	AC
GEK-201-A	Fits Portable Drum Roller with Air motor	Air

* Explosion Proof motors are rated for Class I Group D, and Class II Groups F and G

Control Station Dimensions for NON-Hazardous Areas

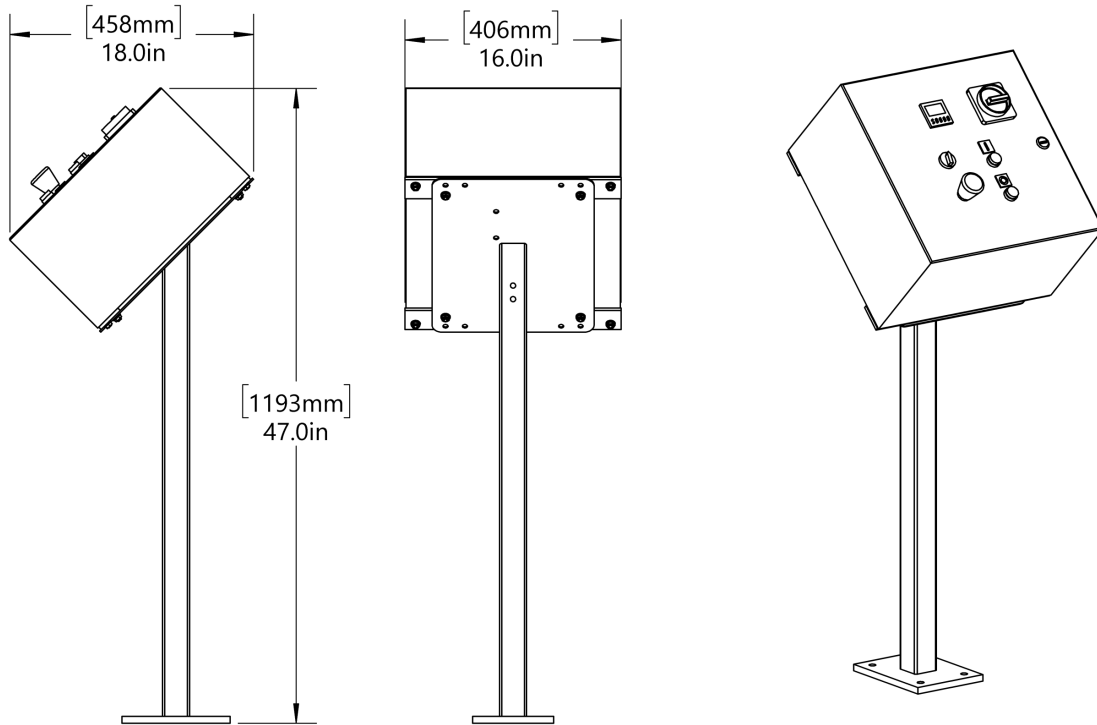

Control Station Dimensions with Explosion-Proof Box for Hazardous Areas

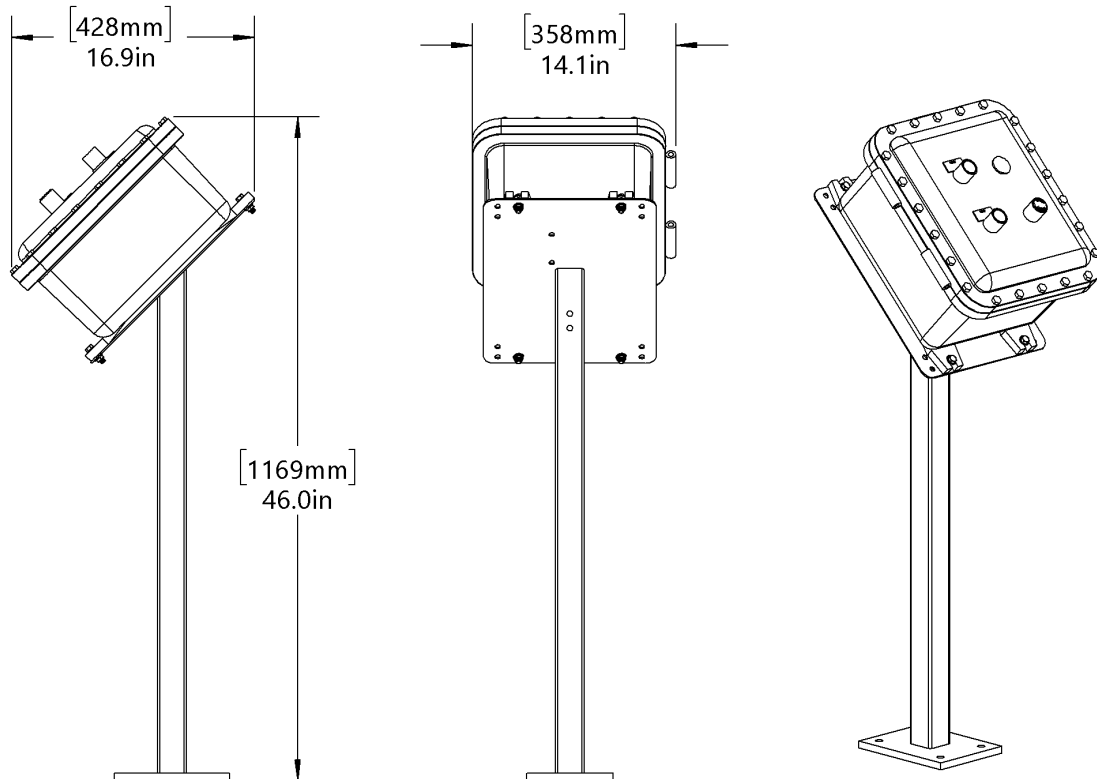

Fixed Speed Wheeled Portable Drum Rollers

Model #	Motor	Volts	Full Load Amp Draw	Drum RPM *	Drum Roller Capacity		Handle Drum Diameter	Maximum Drum Length	Guard Enclosure Kit #	Control Package OUTSIDE Enclosure Model #
					Liquid Contents	Dry Contents **				
201/20-1	1/2 HP, 1-phase, 60Hz	115	7.4	20	500 Lb. (227 kg)	300 Lb. (136 kg)	6" to 28" (15 to 71 cm)	40" (102 cm)	GEK-201-1	N/A
201/20-1-50	1/2 HP, 1-phase, 50Hz	110 / 220	7.2 / 3.6	16	500 Lb. (227 kg)	300 Lb. (136 kg)	6" to 28" (15 to 71 cm)	40" (102 cm)	GEK-201-1	CP-201-1-220-50
201/20-3	1/2 HP, 3-phase, 60Hz	208-230 / 460	2.5-2.0 / 1.0	20	500 Lb. (227 kg)	300 Lb. (136 kg)	6" to 28" (15 to 71 cm)	40" (102 cm)	GEK-201-3	CP-201-3-230 CP-201-3-460
201/20-3-50	1/2 HP, 3-phase, 50Hz	230 / 400	1.7 / 1.0	16	500 Lb. (227 kg)	300 Lb. (136 kg)	6" to 28" (15 to 71 cm)	40" (102 cm)	GEK-201-3	CP-201-3-230-50 CP-201-3-400-50
201/20-575	1/2 HP, 3-phase, 60Hz	575	0.8	20	500 Lb. (227 kg)	300 Lb. (136 kg)	6" to 28" (15 to 71 cm)	40" (102 cm)	GEK-201-3	CP-201-3-575
201/20-E1	Explosion-proof, 1/2 HP, 1-phase, 60Hz	115 / 208-230	7.4 / 3.9-3.7	20	500 Lb. (227 kg)	300 Lb. (136 kg)	6" to 28" (15 to 71 cm)	40" (102 cm)	GEK-201-E1	CP-201-E1-115 CP-201-E1-230
201/20-E1-50	Explosion-proof, 1/2 HP, 1-phase, 50Hz	110 / 220	7.2 / 3.6	16	500 Lb. (227 kg)	300 Lb. (136 kg)	6" to 28" (15 to 71 cm)	40" (102 cm)	GEK-201-E1	CP-201-E1-220-50
201/20-E3	Explosion-proof, 1/2 HP, 3-phase, 60Hz	208-230 / 460	2.1-2.0 / 1.0	20	500 Lb. (227 kg)	300 Lb. (136 kg)	6" to 28" (15 to 71 cm)	40" (102 cm)	GEK-201-E3	CP-201-E3-208 CP-201-E3-230 CP-201-E3-460
201/20-E3-50	Explosion-proof, 1/2 HP, 3-phase, 50Hz	230 / 400	1.7 / 1.0	16	500 Lb. (227 kg)	300 Lb. (136 kg)	6" to 28" (15 to 71 cm)	40" (102 cm)	GEK-201-E3	CP-201-E3-230-50 CP-201-E3-400-50
201/20-E575	Explosion-proof, 1/2 HP, 3-phase, 60Hz	575	0.7	20	500 Lb. (227 kg)	300 Lb. (136 kg)	6" to 28" (15 to 71 cm)	40" (102 cm)	GEK-201-E3	CP-201-E3-575
201/20-A ***	Air Motor	-	-	20	500 Lb. (227 kg)	300 Lb. (136 kg)	6" to 28" (15 to 71 cm)	40" (102 cm)	GEK-201-A	N/A

* RPM is based on standard 22.5" (57.15 cm) diameter 55-gallon (210 liter) drum.

** A shifting dry load exerts greater stress on the drum roller than the fluid motion of a liquid load.

*** Noise Level: 92 dB at distance of 6 feet (1.8 m)

Variable Speed Wheeled Portable Drum Rollers

Model #	Motor	Volts	Full Load Amp Draw	Drum RPM *	Drum Roller Capacity		Handle Drum Diameter	Maximum Drum Length	Guard Enclosure Kit #	Control Package OUTSIDE Enclosure Model #
					Liquid Contents	Dry Contents **				
201VS-1	1/2 HP, 1-phase, 60Hz	115	7.4	Variable 15 to 24	500 Lb. (227 kg)	300 Lb. (136 kg)	6" to 28" (15 to 71 cm)	40" (102 cm)	GEK-201-1	N/A
201VS-1-50	1/2 HP, 1-phase, 50Hz	110 / 220	7.2 / 3.6	Variable 13 to 20	500 Lb. (227 kg)	300 Lb. (136 kg)	6" to 28" (15 to 71 cm)	40" (102 cm)	GEK-201-1	CP-201-1-220-50
201VS-3	1/2 HP, 3-phase, 60Hz	208-230 / 460	2.5-2.0 / 1.0	Variable 15 to 24	500 Lb. (227 kg)	300 Lb. (136 kg)	6" to 28" (15 to 71 cm)	40" (102 cm)	GEK-201-3	CP-201-3-230 CP-201-3-460
201VS-3-50	1/2 HP, 3-phase, 50Hz	230 / 400	1.7 / 1.0	Variable 13 to 20	500 Lb. (227 kg)	300 Lb. (136 kg)	6" to 28" (15 to 71 cm)	40" (102 cm)	GEK-201-3	CP-201-3-230-50 CP-201-3-400-50
201VS-575	1/2 HP, 3-phase, 60Hz	575	0.8	Variable 15 to 24	500 Lb. (227 kg)	300 Lb. (136 kg)	6" to 28" (15 to 71 cm)	40" (102 cm)	GEK-201-3	CP-201-3-575
201VS-E1	Explosion-proof, 1/2 HP, 1-phase, 60Hz	115 / 208-230	7.4 / 3.9-3.7	Variable 15 to 24	500 Lb. (227 kg)	300 Lb. (136 kg)	6" to 28" (15 to 71 cm)	40" (102 cm)	GEK-201-E1	CP-201-E1-115 CP-201-E1-230
201VS-E1-50	Explosion-proof, 1/2 HP, 1-phase, 50Hz	110 / 220	7.2 / 3.6	Variable 13 to 20	500 Lb. (227 kg)	300 Lb. (136 kg)	6" to 28" (15 to 71 cm)	40" (102 cm)	GEK-201-E1	CP-201-E1-220-50
201VS-E3	Explosion-proof, 1/2 HP, 3-phase, 60Hz	208-230 / 460	2.1-2.0 / 1.0	Variable 15 to 24	500 Lb. (227 kg)	300 Lb. (136 kg)	6" to 28" (15 to 71 cm)	40" (102 cm)	GEK-201-E3	CP-201-E3-208 CP-201-E3-230 CP-201-E3-460
201VS-E3-50	Explosion-proof, 1/2 HP, 3-phase, 50Hz	230 / 400	1.7 / 1.0	Variable 13 to 20	500 Lb. (227 kg)	300 Lb. (136 kg)	6" to 28" (15 to 71 cm)	40" (102 cm)	GEK-201-E3	CP-201-E3-230-50 CP-201-E3-400-50
201VS-E575	Explosion-proof, 1/2 HP, 3-phase, 60Hz	575	0.7	Variable 15 to 24	500 Lb. (227 kg)	300 Lb. (136 kg)	6" to 28" (15 to 71 cm)	40" (102 cm)	GEK-201-E3	CP-201-E3-575
201VS-A ***	Air Motor	-	-	Variable 15 to 24	500 Lb. (227 kg)	300 Lb. (136 kg)	6" to 28" (15 to 71 cm)	40" (102 cm)	GEK-201-A	N/A

* RPM is based on standard 22.5" (57.15 cm) diameter 55-gallon (210 liter) drum.

** A shifting dry load exerts greater stress on the drum roller than the fluid motion of a liquid load.

*** Noise Level: 92 dB at distance of 6 feet (1.8 m)ww