

**Ergonomic Dispensing of 5-Gallon Cans or Pails**

- Control dispensing from cans or pails
- Increase employee safety
- Reduce spills of valuable contents and environmental contamination
- Handle 5-gallon (19 liter) can
  - Up to 12.25" (31.2 cm) diameter
  - 10" to 19" (25.4 to 48.3 cm) tall
- Capacity: 75 Lb. (34 kg) per Can



**Model 15  
Can Tipper**

Handles one 5-gallon (19 liter) can or pail. Safety lock holds pail in holder.  
Dispensing height: 10" (25 cm)  
Capacity: 75 Lb. (34 kg).



**Model 2-15  
Double Can Tipper**

Handle 1 or 2 5-gallon (19 liter) cans or pails. Dispense from either can.  
Dispense top pail at 34" (86 cm) high  
Ring of top pail holder is 43" (109 cm) high  
Capacity: 75 Lb. (34 kg) per can.



**Model 15-SS  
Stainless Steel Can Tipper**

Same as model 15, but made of type 304 stainless steel



Top Catch

MADE  
IN  
USA

**Dimensions**

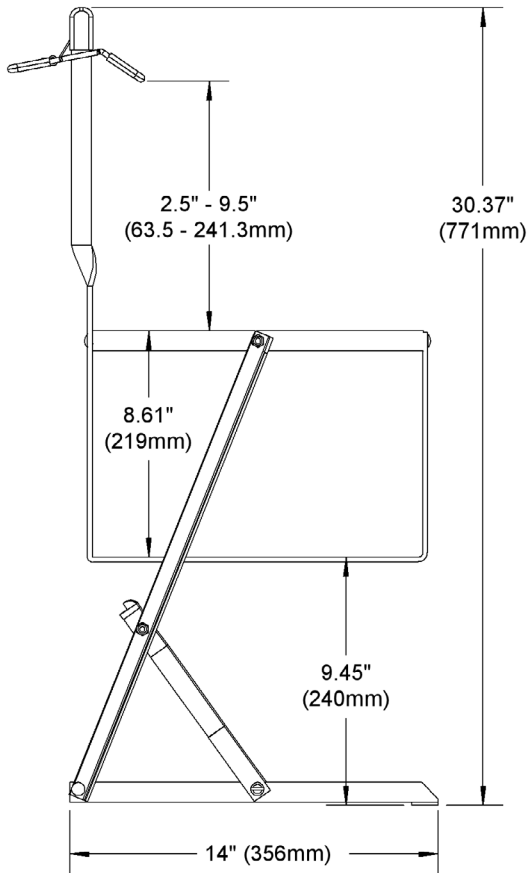
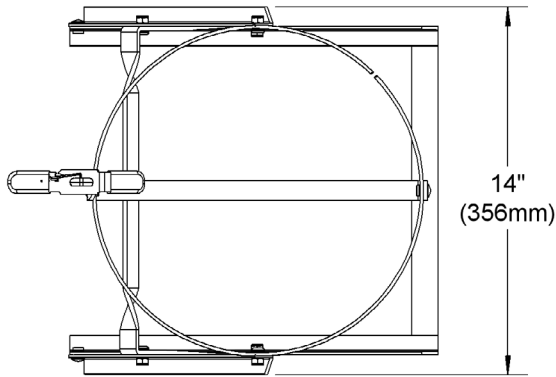

**Models 15 and 15-SS**

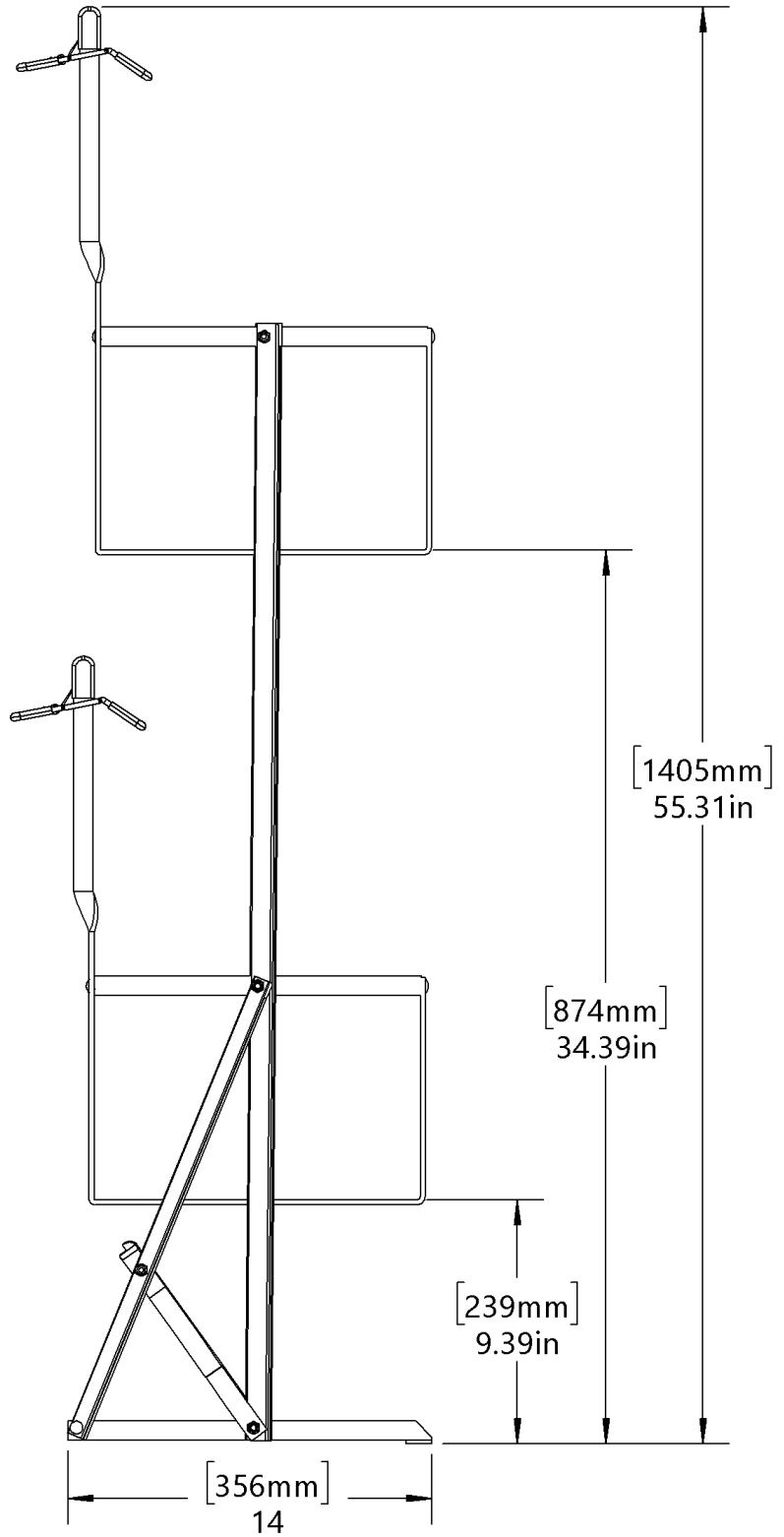

**Model 2-15**

MADE  
IN  
USA