



612 & 622

SPECIFICATIONS SHEET

HORIZONTAL DRUM RACKERS NO-TILT

Efficient & Secure Drum Racking Solutions

Key Features:

- **SAFETY CONSCIOUS** Drum Rackers eliminate dangerous bare fork drum handling
- **Drum rackers with NO tilt function** – ONLY handles horizontal drums
- **Rack drums horizontally** in storage racks, maximizing space efficiency
- **Rack drums side-by-side with virtually zero clearance** for optimal storage
- **Rack drum with faucet or valve in place** to use rack as a dispensing station (max 3 in.)
- **612 Series** racks horizontal drums up to 60" (152 cm) high
- **622 Series** racks horizontal drums up to 104" (264 cm) high
- **Manually operated** or **Powered Hydraulic Pump Lift** for ease of use
- **Durable steel construction** for long-lasting performance
- **Handles drums up to 800 Lb. (363 kg)**
- **Compact footprint** for maneuverability in tight spaces

Benefits:

- Reduces risk of spills and injuries by safely positioning drums
- Saves valuable floor space by optimizing drum storage
- Enhances efficiency in warehouse and manufacturing environments
- Rugged design for reliable, long-term operation

Ideal Applications:

- Warehouses & Distribution Centers
- Manufacturing & Industrial Facilities
- Chemical & Pharmaceutical Storage
- Food & Beverage Processing





MODELS 612 & 622

Horizontal Drum Rackers

SPECIFICATIONS SHEET

SPECIFICATIONS

MODEL	MAX RACKING HEIGHT	MOTOR TYPE	MAX LOAD CAPACITY	DRUM MATERIAL COMPATIBILITY
612	60" (152 cm)	Manual	800 Lb. (363 kg)	Steel, Plastic
612-120	60" (152 cm)	AC, 1HP/115V, TEFC	800 Lb. (363 kg)	Steel, Plastic
612-124	60" (152 cm)	Air, Vane Type	800 Lb. (363 kg)	Steel, Plastic
612-125	60" (152 cm)	DC, 12V	800 Lb. (363 kg)	Steel, Plastic
622	104" (264 cm)	Manual	800 Lb. (363 kg)	Steel, Plastic
622-120	104" (264 cm)	AC, 1HP/115V, TEFC	800 Lb. (363 kg)	Steel, Plastic
622-124	104" (264 cm)	Air, Vane Type	800 Lb. (363 kg)	Steel, Plastic
622-125	104" (264 cm)	DC, 12V	800 Lb. (363 kg)	Steel, Plastic

*All models handle 55-gallon drums.

POWER LIFT MODELS

POWER SUFFIX	MOTOR TYPE	MOTOR CONTROL	SHIP WEIGHT ADDER
-120	AC, 1HP/115V, TEFC	Switch, Cord, Plug	40 lb. (18.1 kg)
-124	Air, Vane Type	On/Off Valve	25 lb. (11.4 kg)
-125	DC, 12V	Built-in	85 lb. (38.6 kg)

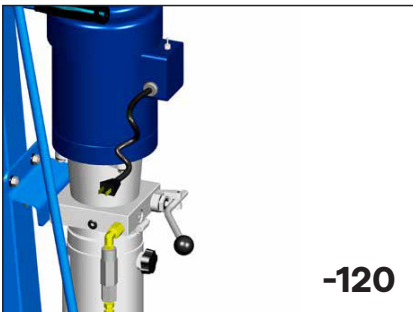

-120

Electric Power Lift

Use switch to raise drum. Lower drum with manual release valve.

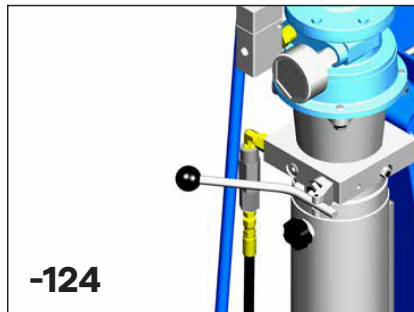

-124

Air Motor Power Lift

Use on/off valve to raise the drum. Lower drum with manual release valve. Air motor Requirements: 40 to 60 PSI at 40 SCFM.

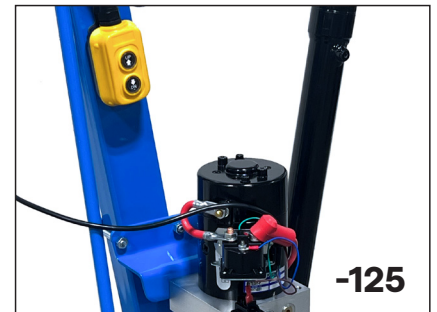

-125

Battery Power Lift

Self contained battery power-lift. Operate battery power controls to raise and lower drum. Separate charger is included.



MODELS 612 & 622

Horizontal Drum Rackers

SPECIFICATIONS SHEET

MORSE MODEL 612

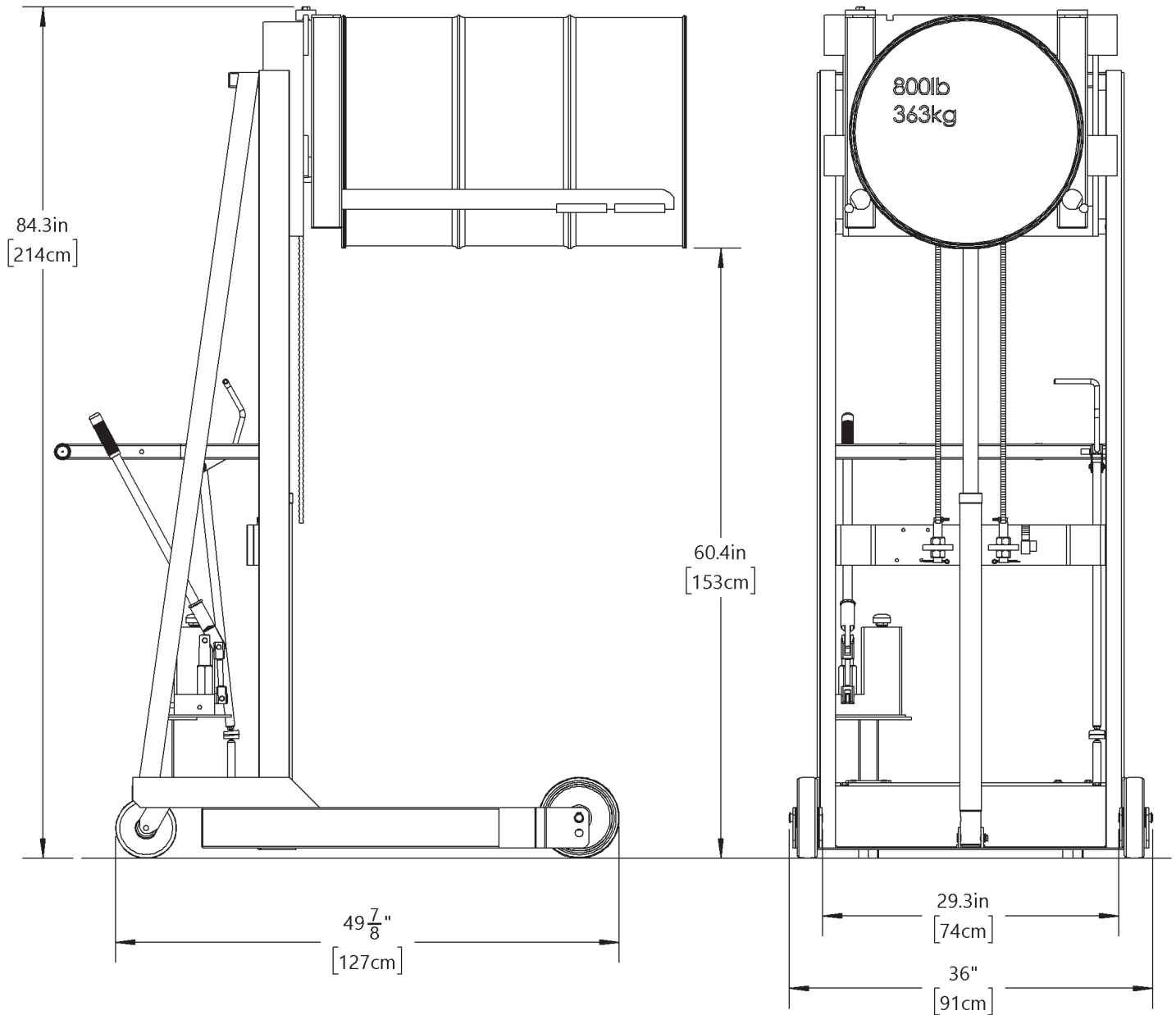



MODELS 612 & 622

Horizontal Drum Rackers

SPECIFICATIONS SHEET

MORSE MODEL 622

