

CONTENTS

- Receiving Procedures
- Warranty
- Safety Information
- Description
- Installation Instructions

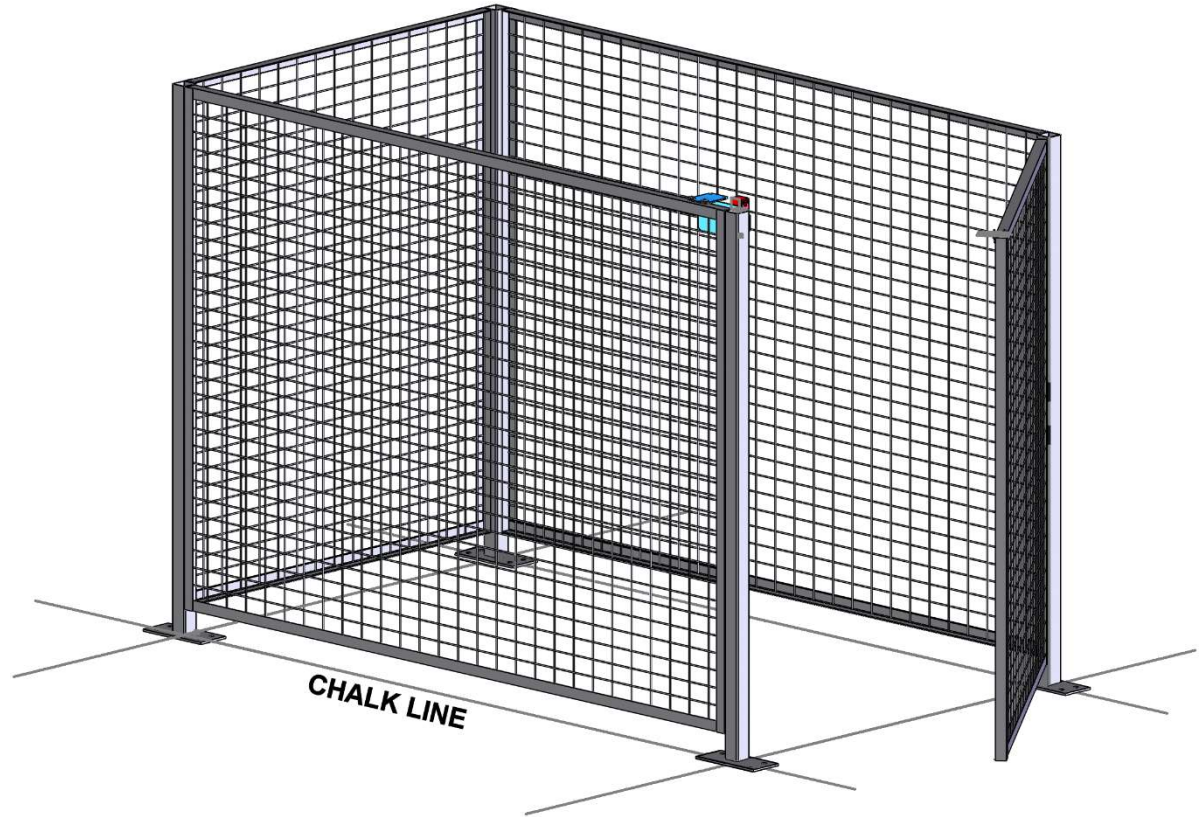

Receiving Procedures

Every Morse drum handler is inspected prior to shipping. However, damage may be incurred during transit.

- Check for visible damage. If you choose to accept damaged freight, always sign noting the damage on the **BILL OF LADING**.
- Document the damage and have the truck driver sign. We recommend keeping a digital camera at your receiving dock for this purpose.
- Open packages expeditiously to check the condition of the goods. There is only a 24 hour window to notify the carrier of any concealed damage.
- **IMMEDIATELY REPORT ALL DAMAGE TO THE SHIPPING COMPANY!** Then you may contact Morse for assistance with your freight claim.
- Morse Manufacturing will not be held responsible for any damaged freight that is not signed for as damaged.

Delivery to non-business addresses without a loading dock result in additional freight charges. Residential delivery fees, inside delivery fees, re-delivery charges, and lift gate services will be added by the truck line, and are non-negotiable.

Limited 2 Year Warranty

Morse drum handling equipment is guaranteed against defects in workmanship or materials for **TWO YEARS** when used properly within its rated capacity. Warranty does not cover wear from normal use or damage from accident or abuse. Motors and other purchased parts carry the warranties of their manufacturers.

For warranty claims, contact your Morse Dealer to obtain a return authorization number, and for return freight advice. Return freight must be prepaid.

In all instances, liability is limited to the purchase price paid or to repairing or replacing the product. Customer assumes liability for any modifications, unauthorized repairs or parts substitution.

Safety Information

While Morse Manufacturing Co. drum handling equipment is engineered for safety and efficiency, a high degree of responsibility must be placed upon the machine operator to follow safe practices, based primarily on common sense, upon which true safety depends.

Failure to follow the safety precautions in this manual can result in personal injury or property damage. Observe the same precautions as with similar machinery where carelessness in operating or maintenance is hazardous to personnel. Carefully read the safety precautions below and throughout this manual.

Review the Material Safety Data Sheet(s) for the material(s) in the drum(s) and take all necessary precautions. Safety shoes, work gloves, hard hat and other personal protective devices are recommended.

Prior to initial use, inspect all moving parts and test rotation of wheels. Perform necessary inspections, operator training, etc.

General Information

The following General Installation Instructions should be used as a guide for installing guard enclosures. Because of the varying job site conditions, and infinite layout possibilities, there is no “recommended” way to install the product. **Good common sense and proper safety precautions must be used during installation.** The guard enclosure may be unstable during installation; proper temporary bracing should be used until all hardware is tightened and the guard enclosure is properly anchored to the floor. Permanent field bracing may be installed at installer’s/owner’s discretion. Install problems arising from job site conditions should be referred to a professional installer.

Tools Recommended

Chalk line and marker	Drill with adjustable clutch and 3/8” nut drivers	
Tape Measure	Hammer Drill with 3/8” masonry bit	(2) C Clamps or Vise-Grip ® type clamps
Level	(2) 9/16” open end wrenches	#1 and #2 Phillips Head Screw Driver
Hacksaw	(2) 9/16” deep socket ratchets	1/2” deep socket or 1/2” open end wrench

Self-tapping Screw Installation Recommendations

When installing self-tapping screws, use standard variable speed screw gun equipped with an adjustable clutch or depth locating nose piece. Take care not to over tighten or strip. Set drill accordingly. **DO NOT USE IMPACT GUN WHEN INSTALLING Self-tapping SCREWS.** Securely clamp component parts in place before attaching with self-tapping screws.

Installer Tips

1. Installation is best accomplished with a two or three person crew.
2. Before starting, review all installation instructions pertinent to your layout (i.e. panels, doors, etc.)
3. “Face Side” of partition is outside, where nuts and bolts will NOT be visible or accessible. “Inside” of the partition has one leg of the panel frame pointing in. Assembly hardware will be on the inside of most layouts.
4. Panels install horizontally between posts with 2” mesh opening parallel to floor.
5. Identify all panels by part number. If possible, stage parts where they will be installed.
6. Make sure all posts are installed plumb (vertically perpendicular to floor). Shims (not provided) may be necessary.
7. Use a 3-1/4” (8.26 cm) spacer block (not provided) to support far end of panel during set up.
8. Begin installation process at a building wall, end or corner of layout.
9. Hinge door is universal, and may be installed left or right hand.
10. Installer should cut off any bolts or hardware protruding into aisle ways or around door openings.
11. Installer should touch up all nicks, marks and scratches with touch up paint provided.

Physical Barrier Height: 1.6 m (5' 3.25")

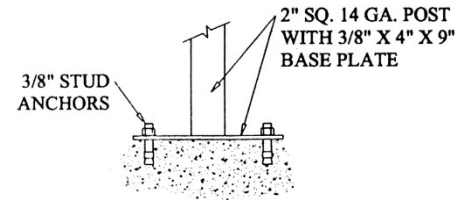
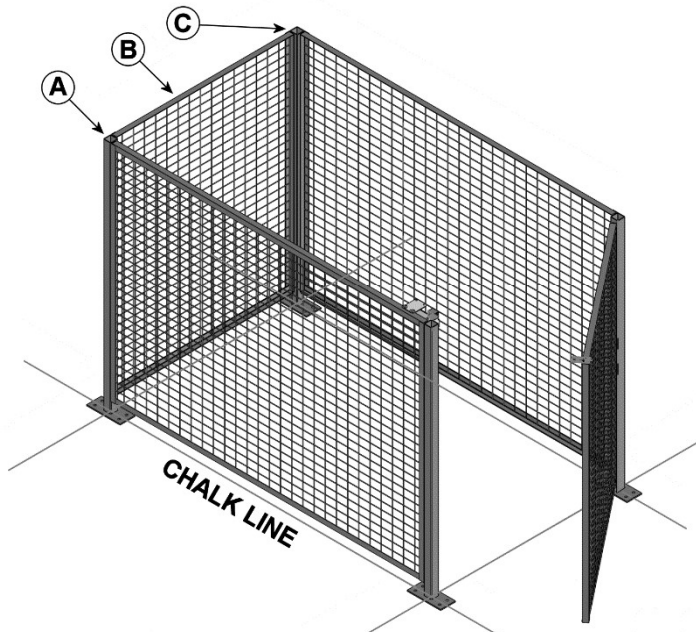

TYPICAL POST TO FLOOR CONNECTION

Fig.1

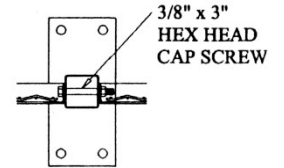

TYPICAL RUN POST CONNECTION

Fig.2

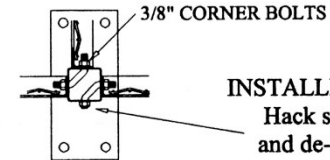

TYPICAL CORNER & TEE POST CONNECTION

Fig.3

INSTALLER NOTE
Hack saw off and de-burr all protruding threads

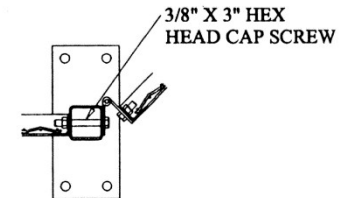

ADJUSTABLE HINGE CONNECTION

Fig.4

Panel and Post Installation

1. Use chalk line to outline partition layout on the floor
 - a. Dimensions below are to outside face of posts
 - b. Post base plates project beyond outline of partition
2. Lag end post (A) to floor per Fig. 1 using anchors
3. Mount panel (B) to post (A)
 - a. Per Fig. 2 for straight run using two 3/8" x 3" straight bolts, or
 - b. Per Fig. 3 for 90 degree corner using two 3/8" corner bolts, or
 - c. Per Fig. 4 for adjustable angle, mount hinge with 3/8" x 3" straight bolts, or
 - d. If mounting directly to building wall skip this step.
 - e. NOTE: Panels install horizontally; 5.1 cm (2") opening parallel with floor.
4. Attach opposite end of panel (B) to second post (C).
 - a. Per Fig. 2 for run post, or
 - b. Per Fig. 3 for corner post.
5. Lag post to floor using anchors.

Barrier Hinge Door - Outside swing right hand shown

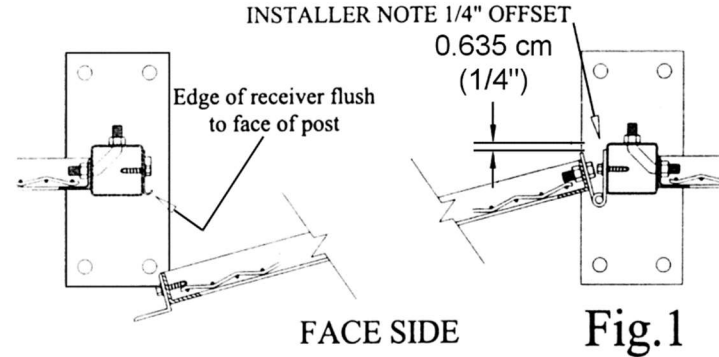
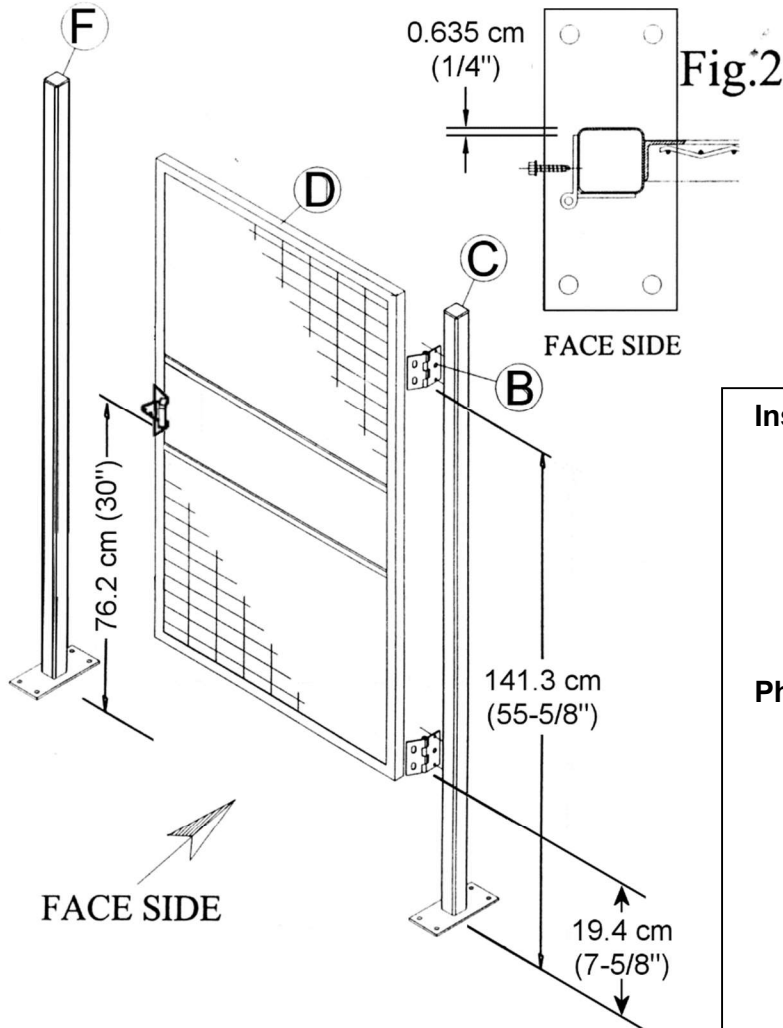

Installer Notes

- Component parts attach using self-tapping screws. Use variable speed screw gun with adjustable clutch or depth locating nose piece. Use care not to over tighten and strip threads. **DO NOT USE IMPACT TYPE GUNS.** Securely clamp part in place before attaching with self-tapping screws.
- The dimensions shown on this page are for standard physical barrier hinge doors 152.4 cm (5'-0") tall with a sweep space of 9.2 cm (3-5/8") from floor to bottom of gate.
- When attaching hinge to door post, wrap hinge around post (as shown in drawing) to set proper offset alignment.
- Partition wall should be set up and anchored to floor, with posts plumb before attempting to install doors.

Physical Barrier Hinge Door Outside Swing

- Check opening width at floor, and anchor posts to floor.
 - Check that posts are plumb and opening is square.
- Attach hinges (B) to door post (C) using two self-tapping screws per hinge.
 - Note hinge placement offset detailed in Fig.1 and install tip Fig. 2.
 - If necessary, remove two 3/8" x 3" panel mounting bolts and replace with corner bolts. Cut off and file smooth any protruding bolt threads.
- Attach door panel (D) to hinges with two 3/8" x 1" bolts and nuts per hinge.
 - Set desired sweep space: 152.4 cm (3-5/8") for stock door.



- Yellow handle bracket with magnet mount
- Black plastic handle
- Rubber coated magnet with threaded stud
- (2) 1/4" Button head cap screw
- Washer
- Acorn head finishing nut

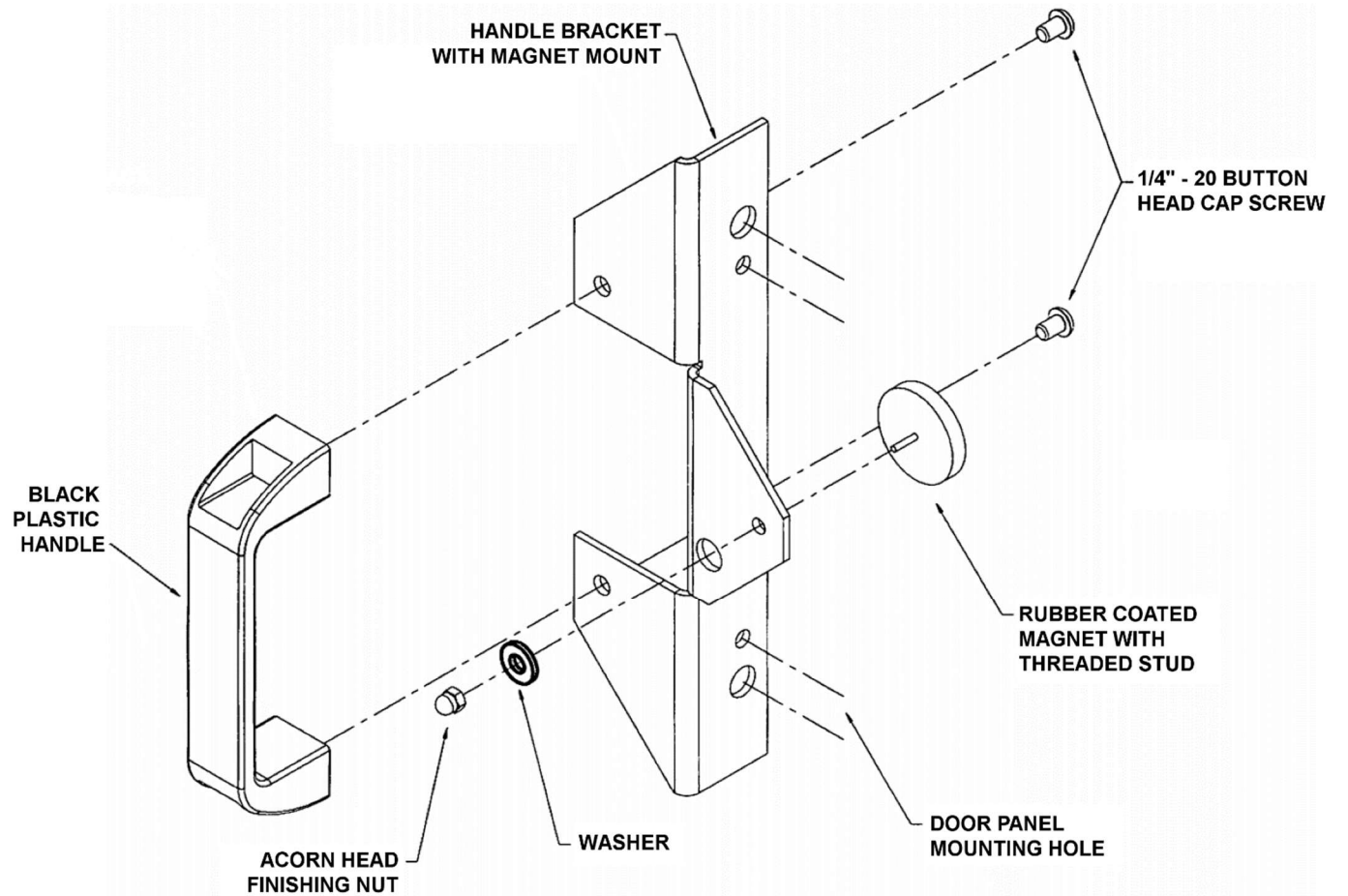



Enclosure Kit packaged for domestic shipment will arrive on pallet as shown.



Enclosure Kit exported from the USA with drum rotator are packaged in crate with the rotator.



Position the drum rotator at the desired location, ensuring there is ample room for enclosure, and for loading a drum onto the drum rotator.



Attach enclosure side panels to posts with provided hardware.

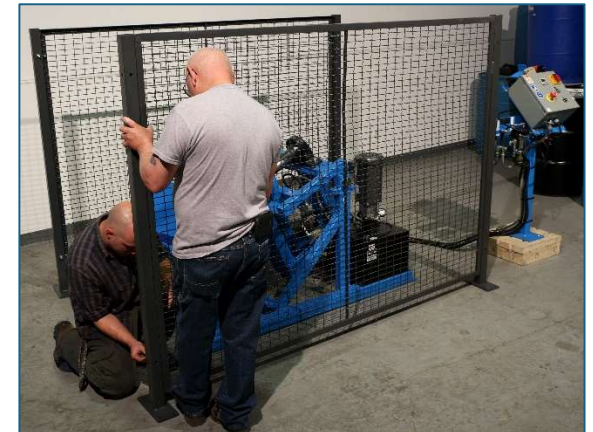



Attach enclosure end panel to posts with provided hardware.



Attach hinges to enclosure door with bolts and nuts.



Use spacer blocks (not provided) to support door panel during set up.



Drill holes for hinges in posts to mount door at desired height.



Attach top door hinge to post with self-tapping screws.



Attach bottom door hinge to post with self-tapping screws.

Installation of Interlock Switch Assembly (Kit 5152KIT-P) for **NON Explosion Proof Enclosures**

Kit 5152KIT-P			
ITEM	QTY.	PART #	DESCRIPTION
1	1	5151-P	BEAM FASTENER, KEY SAFE SWITCH
2	1	4823A-P	KEY, SAFETY SWITCH, DRILLED
3	1	1518-P	NUT, 1/4-20 NYLON LOCK
4	1	1866-P	WASHER, 1/4 USS 3/4 OD
5	1	4822-P	SWITCH, AC SAFETY, CAGE
6	4	1867-P	BHCS, 10-24 X 1-3/4
7	4	1869-P	NUT, 10-24 NYLON LOCK
8	1	6483-P	MOUNT, SAFETY SWITCH, LC
11	1	4574-P	CABLE, INTERLOCK, 22'
12	9	2182-P	WIRE / CABLE TIE, 3-5/8
13	1	5838-P	CORD GRIP, M20, SWITCH, BOX
14	4	3292-P	WASHER, SAE 10 7/32 ID 1/2 OD



Ensure switch (item 5) is configured to receive key (item 2) with latch on left side of door.



If necessary, reverse orientation of switch. . .



. . .and re-assemble switch.

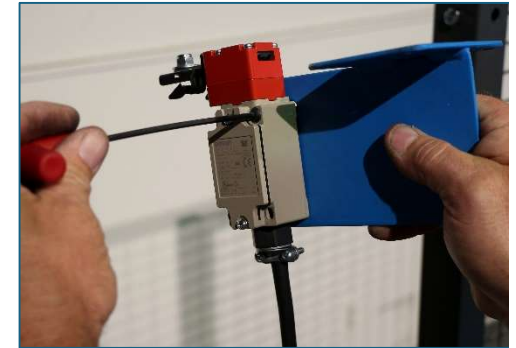

Attach switch to mounting plate using two bolts and two nuts.



Mark where to drill holes in top of side panel for switch mounting plate.



Drill holes for switch mounting plate.



Install switch mounting plate on top of side panel with two bolts, two nuts and 4 washers.



Install key on the door of the enclosure so that it aligns with the switch on the side panel.



Close enclosure and verify that the key aligns properly with the switch. If key is not aligned properly, adjust accordingly. Key may be adjusted by loosening its screws and moving, then re-tightening screws. Use zip ties to retain cable from switch to control station.

