

PDS 30/40

SELF-PROPELLED, STRADDLE LIFT TRUCK

**Operation
Maintenance
Repair Parts List**

WARNING

Do not operate this truck unless you have been authorized and trained to do so, and have read all warnings and instructions in Operator's Manual and on this truck.

Do not operate this truck until you have checked its condition. Give special attention to tires, horn, battery, controller, lift system (including forks or attachments, chains, cables and limit switches), brakes, steering mechanism, guards and safety devices.

Operate truck only from designated operating position. Never place any part of your body into the mast structure or between the mast and the truck. Do not carry passengers. Keep feet clear of truck and wear foot protection.

Observe applicable traffic regulations. Yield right of way to pedestrians. Slow down and sound horn at cross aisles and wherever vision is obstructed.

Start, stop, travel, steer and brake smoothly. Slow down for turns and on uneven or slippery surfaces that could cause truck to slide or overturn. Use special care when traveling without load as the risk of overturn may be greater.

Travel with lifting mechanism as low as possible. Always look in direction of travel. Keep a clear view, and when load interferes with visibility, travel with load trailing.

Use special care when operating on ramps travel slowly, and do not angle or turn. Travel with load downhill.

Do not overload truck. Check nameplate for capacity and load center information.

When using forks, space forks as far apart as load will permit. Before lifting, be sure load is centered, forks are completely under load, and load is as far back as possible against load backrest.

Do not handle unstable or loosely stacked loads. Use special care when handling long, high or wide loads, to avoid losing the load, striking bystanders, or tipping the truck.

Do not handle loads which are higher than the load backrest or load backrest extension unless load is secured so that no part of it could fall backward.

Elevate forks or other lifting mechanism only to pick up or stack a load. Watch out for obstructions, especially overhead.

Do not lift personnel except on a securely attached specially designed work platform. **USE EXTREME CARE WHEN LIFTING PERSONNEL.** Make sure mast is vertical, place truck controls in neutral and apply brakes. Lift and lower smoothly. Remain in operating position or immediate vicinity as long as personnel are on the work platform. Never transport personnel on forks or work platform.

Do not allow anyone to stand or pass under load or lifting mechanism.

When leaving truck, neutralize travel control, fully lower lifting mechanism and set brake. When leaving truck unattended, also shut off power.

TABLE OF CONTENTS

Section	Page	Section	Page
1		6	
DESCRIPTION	1-1	6-1. BRAKES	6-1
1-1. INTRODUCTION.....	1-1	6-1.1. AIR GAP ADJUSTMENT.....	6-1
1-2. GENERAL DESCRIPTION.....	1-1	12-2017.6-1	
1-3. SAFETY FEATURES.....	1-1	6-1.2. STOPPING DISTANCE ADJUSTMENT.....	6-2
2		6-1.3. BRAKE ASSEMBLY REPLACEMENT	6-2
OPERATION.....	2-1	7	
2-1. GENERAL.....	2-1	TRANSMISSION, DRIVE WHEEL, LOAD WHEEL.....	7-1
2-2. OPERATING PRECAUTIONS.....	2-1	7-1. DRIVE WHEEL.....	7-1
2-3. BEFORE OPERATION	2-2	7-2. TRANSMISSION.....	7-1
2-4. GENERAL CONTROL OPERATION.....	2-4	7-3. LOAD WHEEL.....	7-1
2-5. DRIVING AND STOPPING PROCEDURES.....	2-4	7-3.1. REMOVAL	7-1
2-6. BELLY-BUTTON SWITCH.....	2-4	7-3.2. LOAD WHEEL INSTALLATION.....	7-1
2-7. STEERING ARM GAS SPRING.....	2-5	8	
2-8. LIFT AND LOWER CONTROLS.....	2-5	ELEVATION SYSTEM SERVICING.....	8-1
2-9. LOADING AND UNLOADING.....	2-5	8-1. GENERAL.....	8-1
2-10. PARKING.....	2-5	8-2. LIFT CHAIN LENGTH ADJUSTMENT.....	8-1
3		8-2.1. TELESCOPIC.....	8-1
PLANNED MAINTENANCE.....	3-1	8-2.2. TRIMAST FREE LIFT CHAIN.....	8-3
3-1. GENERAL.....	3-1	8-2.3. TRIMAST SECONDARY LIFT CHAIN.....	8-3
3-2. MONTHLY AND QUARTERLY CHECKS.....	3-1	8-3. LIFT CHAIN WEAR INSPECTION.....	8-3
3-3. BATTERY CARE.....	3-1	8-4. LIFT CHAIN REPLACEMENT.....	8-5
3-3.1. GENERAL.....	3-1	8-4.1. TELESCOPIC.....	8-5
3-3.2. SAFETY RULES	3-2	8-4.2. TRIMAST FREE LIFT CHAIN.....	8-5
3-3.3. BATTERY CARE AND CHARGING.....	3-2	8-4.3. TRIMAST SECONDARY LIFT CHAIN.....	8-5
3-3.4. BATTERY CLEANING	3-2	8-5. LIFT CYLINDERS.....	8-5
3-3.5. MAINTENANCE FREE BATTERIES	3-3	9	
3-4. CHARGING BATTERIES.....	3-3	HYDRAULIC SYSTEM SERVICING.....	9-1
3-5. LUBRICATION.....	3-4	9-1. LINES AND FITTINGS	9-1
3-6. LIFT CHAIN MAINTENANCE.....	3-4	9-2. HYDRAULIC PUMP, MOTOR, AND RESERVOIR ASSY	9-1
4		9-2.1. REMOVAL	9-1
TROUBLESHOOTING.....	4-1	9-2.2. DISASSEMBLY AND REASSEMBLY	9-1
4-1. GENERAL.....	4-1	9-2.3. INSTALLATION	9-2
4-2. CONTROLLER TROUBLESHOOTING	4-4	9-2.4. LIFT CYLINDER (TELESCOPIC).....	9-3
4-2.1. ZAPI HANDSET	4-4	9-2.5. LIFT CYLINDER (TRIMAST FREE LIFT).....	9-6
4-2.2. FAULT DETECTION.....	4-4	9-2.6. LIFT CYLINDER (TRIMAST SECONDARY).....	9-9
4-2.3. TESTING TRUCK OPERATION.....	4-4	10	
4-2.4. SETTINGS AND ADJUSTMENTS	4-5	ELECTRICAL COMPONENTS	10-1
5		10-1. ELECTRICAL CONTROL PANEL	10-1
STEER ARM, CONTROL HEAD & COMPARTMENT.....	5-1	10-1.1.MAINTENANCE	10-1
5-1. CONTROL HEAD.....	5-1	10-1.2.CLEANING	10-1
5-1.1. CAP ASSEMBLY REMOVAL.....	5-1	10-1.3.PANEL REMOVAL.....	10-1
5-1.2. CAP ASSEMBLY INSTALLATION.....	5-2	10-1.4.PANEL DISASSEMBLY.....	10-1
5-1.3. CONTROL HEAD REMOVAL	5-3	10-1.5.PANEL INSTALLATION.....	10-1
5-1.4. CONTROL HEAD INSTALLATION	5-3	10-2. HORN REPLACEMENT	10-3
5-1.5. SPEED POTENTIOMETER REPLACEMENT.....	5-3	10-3. PUMP MOTOR.....	10-4
5-1.6. BELLY-BUTTON SWITCH REPLACEMENT.....	5-3	10-4. DRIVE MOTOR.....	10-4
5-1.7. HORN SWITCH REPLACEMENT.....	5-4	10-4.1.MOTOR REMOVAL.....	10-4
5-1.8. LIFT & LOWER SWITCH REPLACEMENT.....	5-6	10-4.2.MOTOR INSTALLATION.....	10-4
5-2. STEERING ARM.....	5-6	10-5. DEADMAN SWITCH.....	10-4
5-2.1. RETURN SPRING REPLACEMENT.....	5-6	10-5.1.REPLACEMENT.....	10-4
5-2.2. STEERING ARM REMOVAL.....	5-6	11	
5-2.3. STEERING ARM INSTALLATION.....	5-6	OPTIONAL EQUIPMENT.....	11-1
5-3. COMPARTMENT COVERS.....	5-6	11-1. LOAD BACKREST.....	11-1
5-3.1. REMOVAL.....	5-6	12	
5-3.2. INSTALLATION.....	5-6	ILLUSTRATED PARTS BREAKDOWN	12-1

TABLE OF CONTENTS - CONTINUED

Figure	Page	Figure	Page
1-1	NAME PLATE..... 1-1	10-3	TRANSMISSION, MOTOR, BRAKE ASSEMBLY..... 10-5
1-2	PDS LIFT TRUCK..... 1-2	12-1	STEERING SYSTEM..... 12-2
2-1	LOAD CENTER..... 2-1	12-2	CONTROL HEAD..... 12-4
2-2	SAMPLE OF OPERATOR CHECK LIST..... 2-3	12-3	CAP ASSEMBLY..... 12-6
2-3	FORWARD/REVERSE CONTROL..... 2-4	12-4	EMERGENCY REVERSE SWITCH ASSEMBLY..... 12-8
2-4	PUSHBUTTON SWITCHES..... 2-4	12-5	TRANSMISSION, MOTOR, BRAKE ASSEMBLY..... 12-10
2-5	BRAKE ACTUATION..... 2-4	12-6	COMPARTMENT..... 12-12
2-6	BELLY-BUTTON SWITCH..... 2-5	12-7	ADJUSTABLE STRADDLE..... 12-14
3-1	LUBRICATION DIAGRAM..... 3-5	12-8	FIXED STRADDLE (PDS 40 ONLY)..... 12-16
4-1	CONNECTING THE HANDSET..... 4-4	12-9	CASTER (ADJUSTABLE STRADDLE)..... 12-18
4-2	ZAPI HANDSET..... 4-5	12-10	CASTER (FIXED STRADDLE)..... 12-20
4-3	ZAPI HANDSET..... 4-9	12-11	ELEVATION SYSTEM (TELESCOPIC)..... 12-22
4-4	THROTTLE REGULATION..... 4-10	12-12	ELEVATION SYSTEM (TRIMAST)..... 12-24
4-5	ZAPI HANDSET..... 4-11	12-13	FORK CARRIAGE..... 12-26
4-6	ZAPI CONTROLLER CONNECTORS..... 4-13	12-14	CHAIN ASSEMBLY..... 12-28
5-1	CONTROL HEAD..... 5-1	12-15	HYDRAULIC SYSTEM..... 12-29
5-2	STEERING ARM..... 5-2	12-16	PUMP & MOTOR ASSY..... 12-30
5-3	EMERGENCY REVERSE SWITCH ASSEMBLY..... 5-4	12-17	HYDRAULIC SYSTEM (TELESCOPIC)..... 12-32
5-4	CAP ASSEMBLY..... 5-5	12-18	HYDRAULIC SYSTEM (TELESCOPIC)..... 12-34
6-1	BRAKE ASSEMBLY..... 6-1	12-19	HYDRAULIC SYSTEM (TRIMAST)..... 12-36
7-1	TRANSMISSION, MOTOR, BRAKE ASSEMBLY..... 7-2	12-20	HYDRAULIC SYSTEM (TRIMAST)..... 12-38
7-2	ADJUSTABLE STRADDLE..... 7-3	12-21	LIFT CYLINDER (TELESCOPIC)..... 12-40
8-1	CHAIN ASSEMBLY..... 8-1	12-22	FREE LIFT CYLINDER (TRIMAST)..... 12-42
8-2	ELEVATION SYSTEM (TELESCOPIC)..... 8-2	12-23	SECONDARY LIFT CYLINDER (TRIMAST)..... 12-44
8-3	MAST (TRIMAST)..... 8-4	12-24	ELECTRICAL SYSTEM..... 12-46
9-1	HYDRAULIC SYSTEM..... 9-2	12-25	ELECTRICAL PANEL..... 12-48
9-2	MAST (TELESCOPIC)..... 9-4	12-26	DRIVE MOTOR..... 12-50
9-3	LIFT CYLINDER (TELESCOPIC)..... 9-5	12-27	WIRING HARNESS..... 12-52
9-4	MAST (TRIMAST)..... 9-7	12-28	WIRING CABLES..... 12-53
9-5	FREE LIFT CYLINDER (TRIMAST)..... 9-8	12-29	BATTERY COMPARTMENT..... 12-54
9-6	SECONDARY LIFT CYLINDER (TRIMAST)..... 9-10		
10-1	ELECTRICAL SYSTEM..... 10-2		
10-2	ELECTRICAL PANEL..... 10-3		
Table	Page	Table	Page
2-1	OPERATOR CHECKS..... 2-2	4-1	TROUBLESHOOTING CHART..... 4-1
3-1	MONTHLY AND QUARTERLY INSPECTION AND SERVICE CHART..... 3-1	4-2	SET OPTIONS..... 4-5
3-2	RECOMMENDED LUBRICANTS..... 3-4	4-3	ADJUSTMENTS..... 4-9
3-3	LUBRICATION CHART..... 3-5	4-4	PARAMETER ADJUSTMENTS..... 4-11
		4-5	ZAPI CONTROLLER CONNECTOR PINS..... 4-13

SECTION 1 DESCRIPTION

1-1. INTRODUCTION.

This publication describes the 24 volt transistor PDS lift truck distributed by Big Lift LLC. Included are operating instructions, planned maintenance instructions, lubrication procedures, corrective maintenance procedures and a complete parts list with part location illustrations.

Users shall comply with all requirements indicated in applicable OSHA standards and current edition of A.N.S.I. B56.1 Part II. By following these requirements and the recommendations contained in this manual, you will receive many years of dependable service from your PDS lift truck.

1-2. GENERAL DESCRIPTION.

The self-propelled PDS 30 truck, lifts and transports payloads up to 3000 pounds on either rigid or adjustable forks. The self-propelled PDS 40 truck, lifts and transports payloads up to 4000 pounds on either rigid or adjustable forks.

The Telescopic truck has either a 104, 126 or 141 inch lift. The TRIMAST truck has either a 158, 177, or 189 inch lift. The TRIMAST fork carriage will free lift the first

4 feet without changing the overall lift height. Then the mast will start to rise. However, if the truck has an optional load backrest, the backrest will raise above the mast before the end of the full free lift.

The forward and reverse motion is controlled by either of two controller levers mounted on the control head. Stopping and turning is controlled by the steering arm. Lift and Lower is controlled by pushbuttons on the control head. The battery powered lift truck is quiet and without exhaust fumes.

The reversible AC motor propels the lift truck in forward or reverse direction throughout the available speed range. The PDS lift truck can be driven with forks raised or lowered; however, the speed is restricted when the platform is raised above a preset limit.

The model number will be found on the name plate (Figure 1-1) along with the serial number, lifting capacity, and load center. Figure 1-2 shows the locations of the truck's main components and controls.

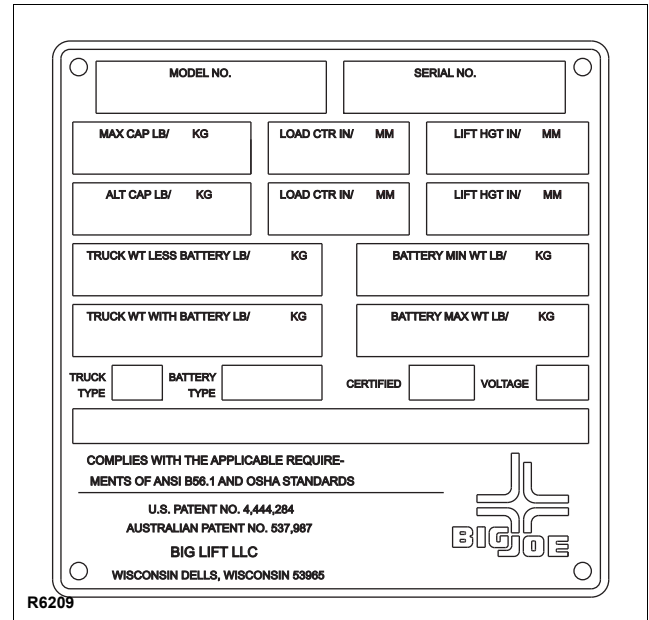
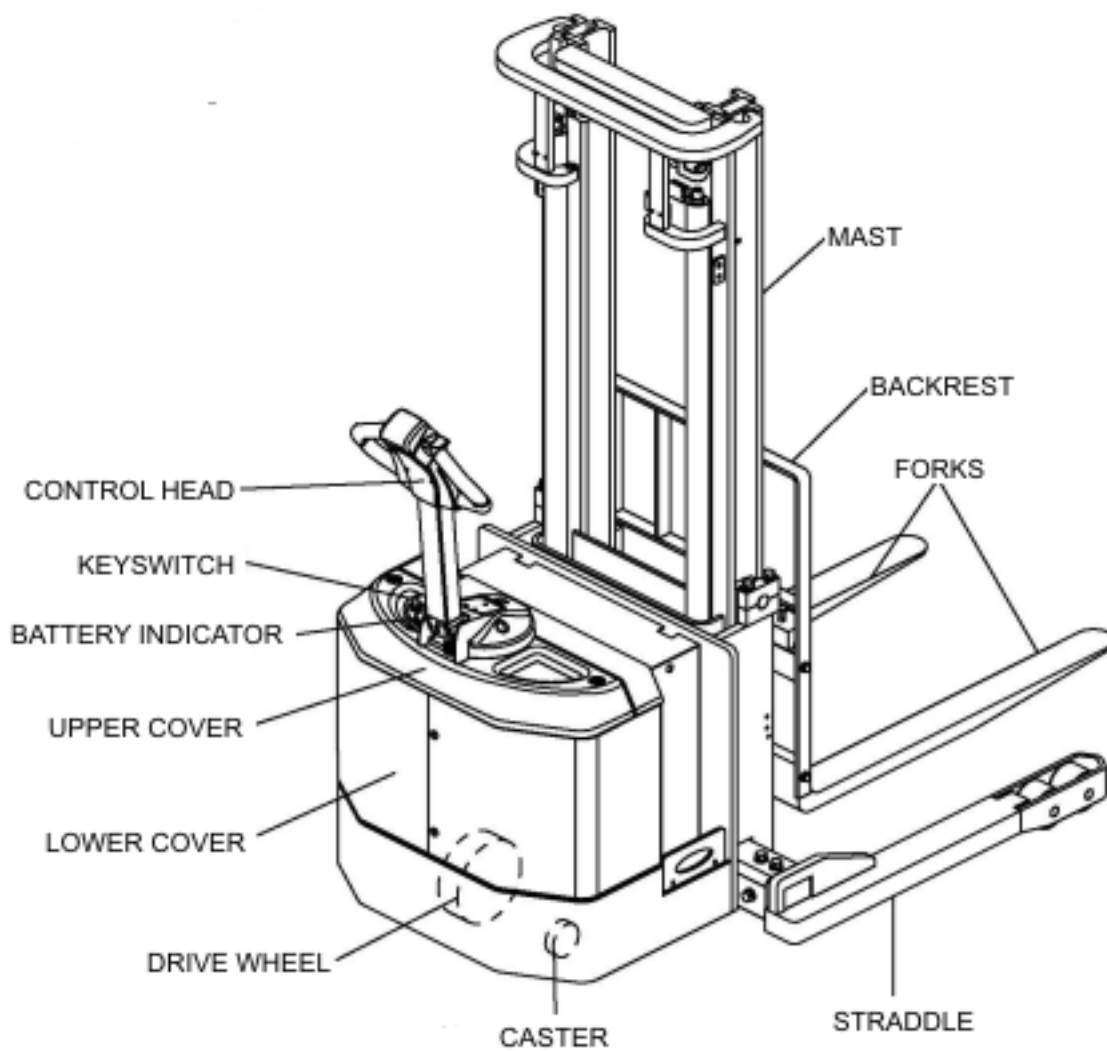

Figure 1-1 Name Plate

1-3. SAFETY FEATURES.

The PDS is designed engineered to provide maximum safety for operator and payload. Some of the safety features incorporated into the design are:

- Dead-man brake to apply the brake and cut off drive power when the steering arm is released.
- Belly-button switch to reverse truck should the operator accidentally pin himself against a wall or obstruction when backing up in slow speed.
- High speed limit switch to restrict speed when fork carriage is raised above the preset limit.
- All control functions automatically return to "OFF" when released.
- Externally accessible quick-disconnect battery plug within operator's reach.
- Separately fused control circuits and power circuits.
- Readily accessible horn button.
- Fork carriage backrest to help stabilize the load.
- Handle to provide a firm hand hold for operator.
- Flow control valve regulates maximum lowering speed within prescribed limits.
- Relief valve maintains hydraulic pressure within prescribed limits.
- High visibility color scheme of truck provides visual alert of truck's presence.
- Battery Indicator
- Casters.



R6765

Figure 1-2. PDS Lift Truck

SECTION 2 OPERATION

2-1. GENERAL.

This section gives detailed operating instructions for the PDS lift truck. The instructions are divided into the various phases of operations, such as operating lift, driving, and stopping. Routine precautions are included for safe operation.

2-2. OPERATING PRECAUTIONS.

WARNING: Improper operation of the lift truck may result in operator injury, or load and/or lift truck damage. Observe the following precautions when operating the PDS lift truck.

The following safety precautions must be adhered to at all times.

- Do not operate this truck unless you have been trained and authorized to do so.
- All warnings and instructions must be read and understood before using the equipment.
- Equipment must not be altered in any way.
- Equipment must be inspected by a qualified person on a regular basis.
- Do not exceed the rated capacity. Overloading may result in damage to the hydraulic system and structural components.

- Be certain that the lifting mechanism is operating smoothly throughout its entire height, both empty and loaded.
- Be sure that mast is vertical - do not operate on a side slope.
- Be sure the truck has a firm and level footing.
- Avoid overhead wires and obstructions.
- Check for obstructions when raising or lowering the fork carriage.
- Do not handle unstable or loosely stacked loads. Use special care when handling long, high, or wide loads to avoid tipping, loss of load, or striking bystanders.
- Center and carry the load as far back as possible toward the fork carriage back rest. The center-of-gravity of the load must not exceed the load center listed on the nameplate. See [Figure 2-1](#) for load center limitations.
- Pick up loads on both forks. Do not pick up on only one fork.
- When traveling, always lower the load as far as possible.

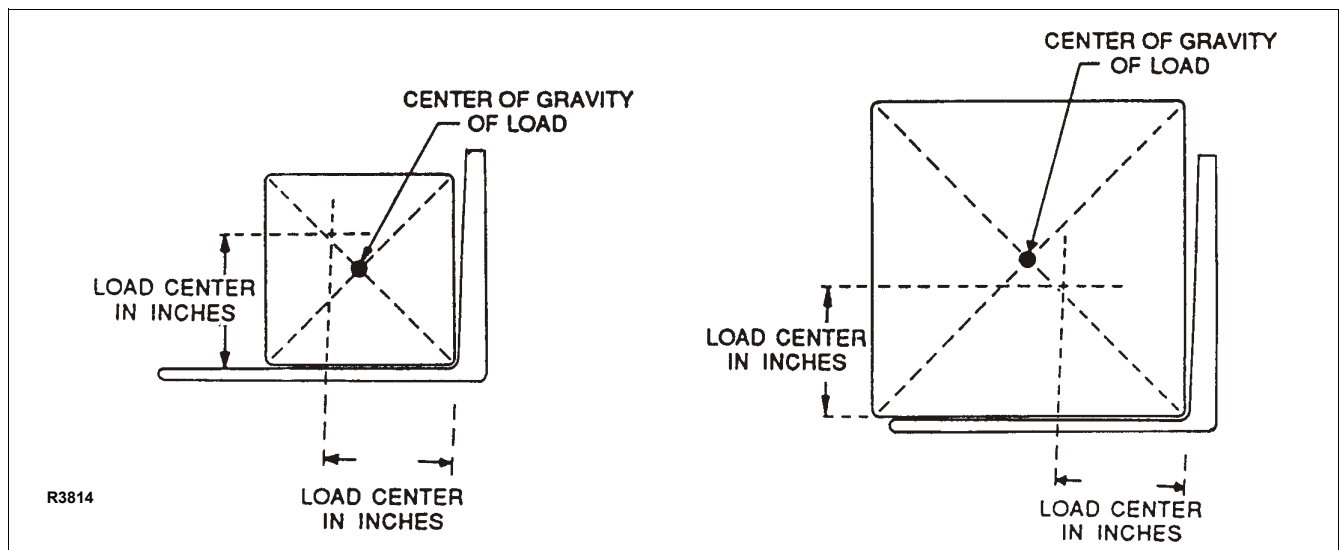

Figure 2-1 Load Center

- When stacking pallets in racks and it is necessary to move the load in a raised position, use caution. Operate truck smoothly.
- Observe applicable traffic regulations. Yield right of way to pedestrians. Slow down and sound horn at cross aisles and wherever vision is obstructed.
- Operate truck only from designated operation position. Never place any part of your body between the mast uprights. Do not carry passengers.
- Do not allow anyone to stand or pass under load or lifting mechanism.
- When leaving truck, neutralize travel control. Fully lower lifting mechanism and set brake. When leaving truck unattended, turn off key switch, remove key and disconnect battery.

2-3. BEFORE OPERATION

The PDS lift truck which should be checked prior to operation. Depending on use, some trucks may require additional checks

Figure 2-2 shows a sample format for an Operator Checklist, which can be modified as necessary to fit your operation.

WARNING: Periodic maintenance of this truck by a QUALIFIED TECHNICIAN is required.

CAUTION: A QUALIFIED SERVICE TECHNICIAN should check the truck monthly for proper lubrication, proper fluid levels, brake maintenance, motor maintenance and other areas specified in the SECTION 3.

WARNING: If the truck is found to be unsafe and in need of repair, or contributes to an unsafe condition, report it immediately to the designated authority. Do not operate it until it has been restored to a safe operating condition. Do not make any unauthorized repairs or adjustments. All service must be performed by a qualified maintenance technician.

Table 2-1 Operator Checks

ITEM	PROCEDURE
Transmission and hydraulic systems.	Check for signs of fluid leakage.
Forks	Check for cracks and damage; and, that they are properly secured.
Chains, cables and hoses	Check that they are in place, secured correctly, functioning properly and free of binding or damage.
Guards and load backrest	Check that safety guards are in place, properly secured and not damaged.
Safety signs	Check that warning labels, nameplate, etc., are in good condition and legible.
Horn	Check that horn sounds when operated.
Steering	Check for binding or looseness in steering arm when steering.
Travel controls	Check that speed controls on control head operate in all speed ranges in forward and reverse and that belly button switch functions.

ITEM	PROCEDURE
Wheels	Check drive wheel for cracks or damage. Move truck to check load for freedom of rotation.
Hydraulic controls	Check operation of lift and lower to their maximum positions.
Brakes	Check that brakes actuate when steering arm is raised to upright position, and when lowered to horizontal position.
Deadman/ Parking brake	Check that steering arm raises to upright position when released and brake applies.
Battery disconnect	Check that battery can be disconnected and reconnected. Check for connector damage.
Battery charge	Check the battery indicator.
High speed limit switch	Allow for enough space to operate truck in high speed. Elevate forks approximately two feet, then test drive truck to check if high speed is cut out.



Electric Truck Daily Operator Check-Off List

Date _____ Operator _____

Truck No. _____ Model No. _____

Dept. _____ Shift _____

Hour Meter
Reading—Drive _____ Hoist _____

Check	O.K. (✓)	Need Maintenance
Tires		
Load Wheels		
Horn		
Lift—Lower Control		
Attachment Operation		
Forward & Reverse Controls		
Steering		
Brakes		
Hydraulic Leaks, Cylinders, Valves, Hoses, Etc.		

R6479

Figure 2-2 Sample of Operator Check List

2-4. GENERAL CONTROL OPERATION.

The speed control (See [Figure 2-3](#)) located on each side of the control head provides fingertip control for driving the truck. Rotate the control in the direction you want to travel. The farther you rotate the control from the neutral position, the faster the truck will travel.

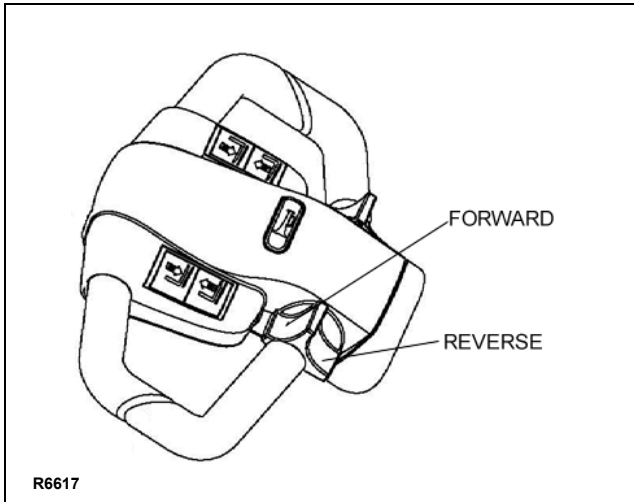

Figure 2-3. Forward/Reverse Control

The pushbutton switches (See [Figure 2-4](#)), located on the front of the control head activate the lift-lower controls and the horn.

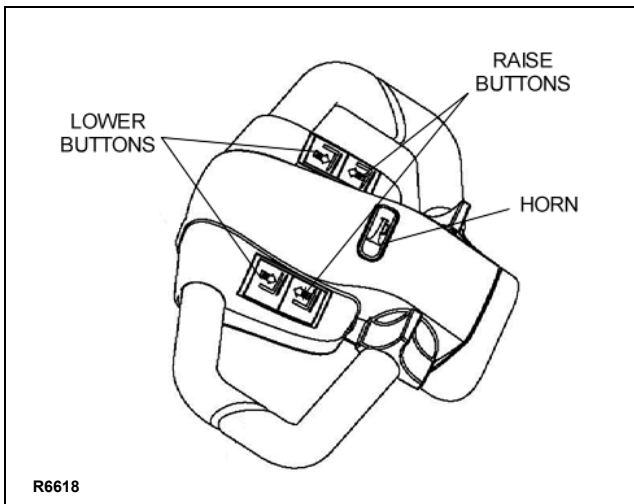

Figure 2-4. Pushbutton Switches

The brake is fully applied by lowering or raising the steering arm. (See [Figure 2-5](#)) All traction control power is shut off when the brake is engaged. When the steering arm is in the upright position, the brake acts as a parking brake. Deadman braking occurs when the handle is released and spring action raises steering arm to the upright position.

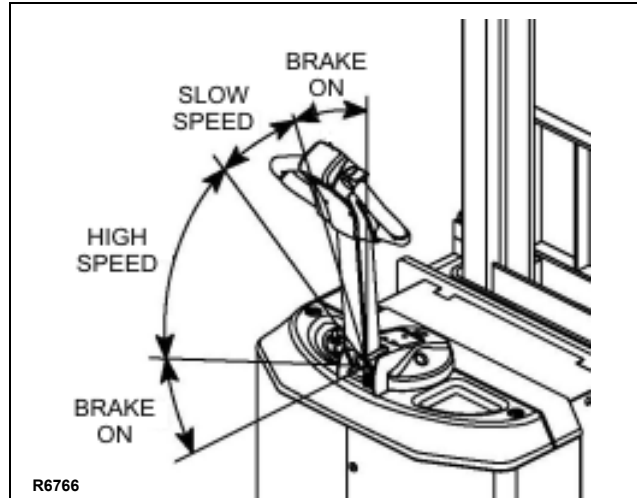

Figure 2-5. Brake Actuation

2-5. DRIVING AND STOPPING PROCEDURES.

1. Connect the batteries and turn on the key switch. Grasp the grips of the steering head so that the speed control can be comfortably operated by either thumb.
2. Lower the steering arm to a comfortable position above horizontal to disengage the brake and to energize the electrical circuits. If the truck is not moved, the electrical circuits will time out and will deenergize. See [Figure 2-5](#).
3. To move forward (with load in front), slowly press the speed control forward. See [Figure 2-3](#). Press the forward speed control farther to increase speed.
4. To slow down or stop, release the speed control and lower or raise the steering arm to the horizontal or vertical position. See [Figure 2-5](#). In those positions, the brake engages, slowing or stopping the truck.
5. Procedures for movement in reverse are the same as in the forward direction except slowly press the speed control backward. See [Figure 2-3](#).

2-6. BELLY-BUTTON SWITCH.

The belly-button switch ([Figure 2-6](#)) minimizes the possibility of the driver being pinned by the steering arm while driving the lift truck in slow speed. If the switch presses against the operator while the lift truck is being driven toward the operator, the switch changes the direction of the lift truck.

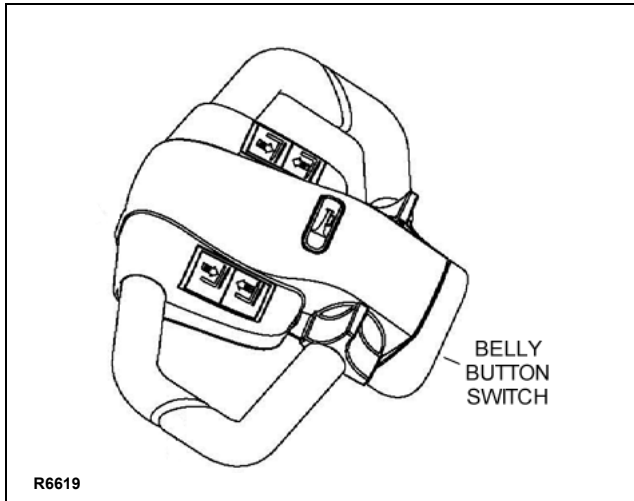

Figure 2-6. Belly-Button Switch

2-7. STEERING ARM GAS SPRING.

The steering arm gas spring automatically raises the steering arm to the upright position when the steering arm is released. If the steering arm does not return fully, the steering arm gas spring requires replacement. Return truck to maintenance for repair.

2-8. LIFT AND LOWER CONTROLS.

Lift/Lower Control buttons are located on the steering control head. ([Figure 2-4](#))

To lift forks, push in either LIFT button and hold until forks reach desired height. To lower forks, push in either LOWER button and hold until forks descend to desired height.

2-9. LOADING AND UNLOADING.

1. Move truck to location where load is to be picked up.
2. Move the truck into position so forks are within pallet or skid, and the load is centered over the forks and as far back as possible.
3. Raise forks to lift load.
4. Drive to area where load is to be placed.
5. Move truck to align load with its new position.
6. Lower the load until it rests squarely in place and the forks are free.
7. Slowly move the truck out from under the load.

2-10. PARKING.

When finished with moving loads, return the truck to its maintenance or storage area. Turn off the key switch and disconnect the batteries. Charge batteries as necessary. Refer to battery care instructions,

NOTES

SECTION 3 PLANNED MAINTENANCE

3-1. GENERAL.

Planned maintenance consists of periodic visual and operational checks, parts inspection, lubrication, and scheduled maintenance designed to prevent or discover malfunctions and defective parts. The operator performs the checks in [SECTION 2](#), , and refers any required servicing to a qualified maintenance technician who performs the scheduled maintenance and any required servicing.

3-2. MONTHLY AND QUARTERLY CHECKS.

[Table 3-1](#) is a monthly and quarterly inspection and service chart based on normal usage of equipment eight hours per day, five days per week. If the lift truck is used in excess of forty hours per week, the frequency of inspection and service should be increased accordingly. These procedures must be performed by a qualified service technician or your Big Lift LLC Service Representative.

3-3. BATTERY CARE.

3-3.1. General

The PDS may be equipped with maintenance free or industrial wet cell batteries.

The care and maintenance of the battery is very important to obtain efficient truck operation and maximum battery life.

CAUTION: Gases produced by a battery can be explosive. Do not smoke, use an open flame, create an arc or sparks in the vicinity of the battery. Ventilate an enclosed area well when charging.

CAUTION: Batteries contain sulfuric acid which may cause severe burns. Avoid contact with eyes, skin or clothing. In case of contact, flush immediately and thoroughly with clean water. Obtain medical attention when eyes are affected. A baking soda solution (one pound to one gallon of water) applied to spilled acid until bubbling stops, neutralizes the acid for safe handling and disposal.

Leakage voltage from battery terminals to battery case can cause misleading trouble symptoms with the truck electrical system. Since components of the truck electrical system are insulated from truck frame, leakage voltage will not normally affect truck operation unless a short circuit or breakdown of circuit wire insulation to truck frame occurs.

A voltage check from battery connector terminal to battery case should indicate near zero volts. Typically, however, the sum of the voltages at both terminals will equal battery volts. This leakage voltage will discharge the battery. As battery cleanliness deteriorates, the usable charge of the battery decreases due to this self discharge.

Table 3-1 Monthly and Quarterly Inspection and Service Chart

VISUAL CHECKS	
INTERVAL	INSPECTION OR SERVICE
Monthly	Check electrical brake for proper operation.
Monthly	Check load wheels for wear. A poly load wheel must be replaced if worn to within 1/16 inch of hub. Check for separation from hub.
Monthly	Check drive wheel for wear. A poly drive wheel must be replaced if worn to within 3/4 inch of hub. Check for separation from hub.
Monthly	Inspect wiring for loose connections and damaged insulation.
Monthly	Inspect contactors for proper operation.
Monthly	Check deadman brake switch for proper operation.
Monthly	Check lift chain tension, lubrication & operation (see paragraph 3-6 .)
Quarterly	Check lift cylinder for leakage.
Quarterly	Check for excessive jerking of steering arm when stopping or starting.
Semi-annually	Inspect for chain wear (See SECTION 8)

Although a leakage voltage reading of zero volts may not be possible, a cleaner battery will have more usable charge for truck operation and not affect operation of electronic devices on the unit.

3-3.2. Safety Rules

- Wear protective clothing, such as rubber apron, gloves, boots and goggles when performing any maintenance on batteries. Do not allow electrolyte to come in contact with eyes, skin, clothing or floor. If electrolyte comes in contact with eyes, flush immediately and thoroughly with clean water. Obtain medical attention immediately. Should electrolyte be spilled on skin, rinse promptly with clean water and wash with soap. A baking soda solution (one pound to one gallon of water) will neutralize acid spilled on clothing, floor or any other surface. Apply solution until bubbling stops and rinse with clean water.
- If truck is equipped with wet cell batteries, keep vent plugs firmly in place at all times except when adding water or taking hydrometer readings. Do not allow dirt, cleaning solution or other foreign material to enter cells. Impurities in electrolyte has a neutralizing effect reducing available charge.
- Do not bring any type of flame, spark, etc., near the battery. Gas formed while the battery is charging, is highly explosive. This gas remains in cell long after charging has stopped.
- Do not lay metallic or conductive objects on battery. Arcing will result.
- Do not touch non-insulated parts of DC output connector or battery terminals to avoid possible electrical shock.
- De-energize all AC and DC power connections before servicing battery.
- Do not charge a frozen battery.
- Do not use charger if it has been dropped or otherwise damaged.

3-3.3. Battery Care and Charging

CAUTION: Never smoke or bring open flame near the battery. Gas formed during charging is highly explosive and can cause serious injury.

1. 1.Charge the battery only in areas designated for that use.
2. 2.Make certain the charger being used matches the voltage and amperage of the truck battery.
3. 3.Before disconnecting or connecting batteries to a charger, make sure the charger is "OFF". If an attempt is made to do this while the charger is "ON", serious injury to you, the battery and the charger could result.
4. 4.Before connecting the battery cable to the trucks receptacle, make sure the key switch is off. The battery cable must be fully connected before the truck is used. If the plug is not making good contact, heat will weld the two parts of the battery connector together, making it difficult to remove and necessary to replace.
5. 5.Battery terminals should be checked and cleaned of corrosion regularly. Good battery terminal contact is essential not only for operation, but also for proper charging of the battery.
6. 6.The charging requirements will vary depending on the use of the truck. The battery should be given as equalizing charge on a weekly basis. This charge should normally be an additional three hours at the finish rate.
7. 7.Make certain battery used meets weight and size requirements of truck. NEVER operate truck with an undersized battery.

3-3.4. Battery Cleaning

For more information please see

Battery Manufacturers Recommendations

3-3.5. MAINTENANCE FREE BATTERIES

Some trucks may be equipped with maintenance free batteries. These batteries are completely sealed, will not require any watering and have a full 80% discharge available.

Sealed Maintenance Free batteries contain a pressure release valve and under normal operating conditions do not require any special ventilation.

CAUTION: Do not try to open this battery or remove the pressure release valve.

Only under severe overcharging, such as connected to an improperly sized charger, will any significant amount of gasses be released from the battery. Also, being a valve regulated battery, it never requires watering.

3-4. CHARGING BATTERIES

Charging requirements will vary depending on depth of discharge and temperature. Follow safety rules when placing a battery on charge.

1. Proceed as follows:
2. Park truck at charging station with carriage lowered and turn the key switch off.
3. Check the condition of the AC cord, the battery connector and battery cables. If there are any cuts in the cable, any exposed wires, loose plugs or connectors, DO NOT attempt to charge the batteries. Contact appropriate personnel for repairs to be made.
4. Disconnect the batteries from the truck and connect the batteries to the charger. Make sure connectors are mated properly.
5. Connect the charger to the appropriate power supply.
6. Follow the instructions for the charger being used.

<p>BATTERY HAZARD</p> 	<p>⚠ DANGER</p> <p>EXPLOSIVE/POISON/CAUSTIC NO SPARKS, FLAMES, SMOKING BATTERY ACID can cause blindness and severe burns SHIELD EYES, AVOID SKIN CONTACT IF SPLASHED flush immediatly with water, get medical help fast.</p> <p>Do not service battery while on charge. Do not connect or disconnect battery from charger while charger is on. Only qualified and experienced personnel should perform maintenance and repair on batteries. Use caution while servicing or removing battery. (Refer to Battery Safety Sheet).</p>
---	---

3-5. LUBRICATION.

Refer to [Table 3-2](#) for the recommended types of grease and oil. [Table 3-3](#) in conjunction with [Figure 3-1](#) identifies the items requiring lubrication.

3-6. LIFT CHAIN MAINTENANCE.

Fully raise and lower fork carriage while observing chains as they move over chain sheaves. Ensure chain is aligned and tracking properly and all links are pivoting freely. With fork carriage fully lowered, spray or brush on a film of SAE 30 or 40 engine oil.

**Table 3-2 Recommended Lubricants
(See [Table 3-3](#) for Application)**

No. 1	Transmission oil—EP SAE 80W-90 Transmission oil—EP SAE 10W-30 (Note)
No. 2	Grease—Lithium base, general purpose.
No. 3	Hydraulic oil-Heavy duty with a viscosity of 150 SUS foam suppressing agent and rust and oxidation inhibitors Hydraulic oil-Heavy duty with a viscosity of 100 SUS foam suppressing agent and rust and oxidation inhibitors (Note)
No. 4	SAE 30 or 40 Engine lubricating oil

NOTE: USED ON COLD CONDITIONED TRUCKS

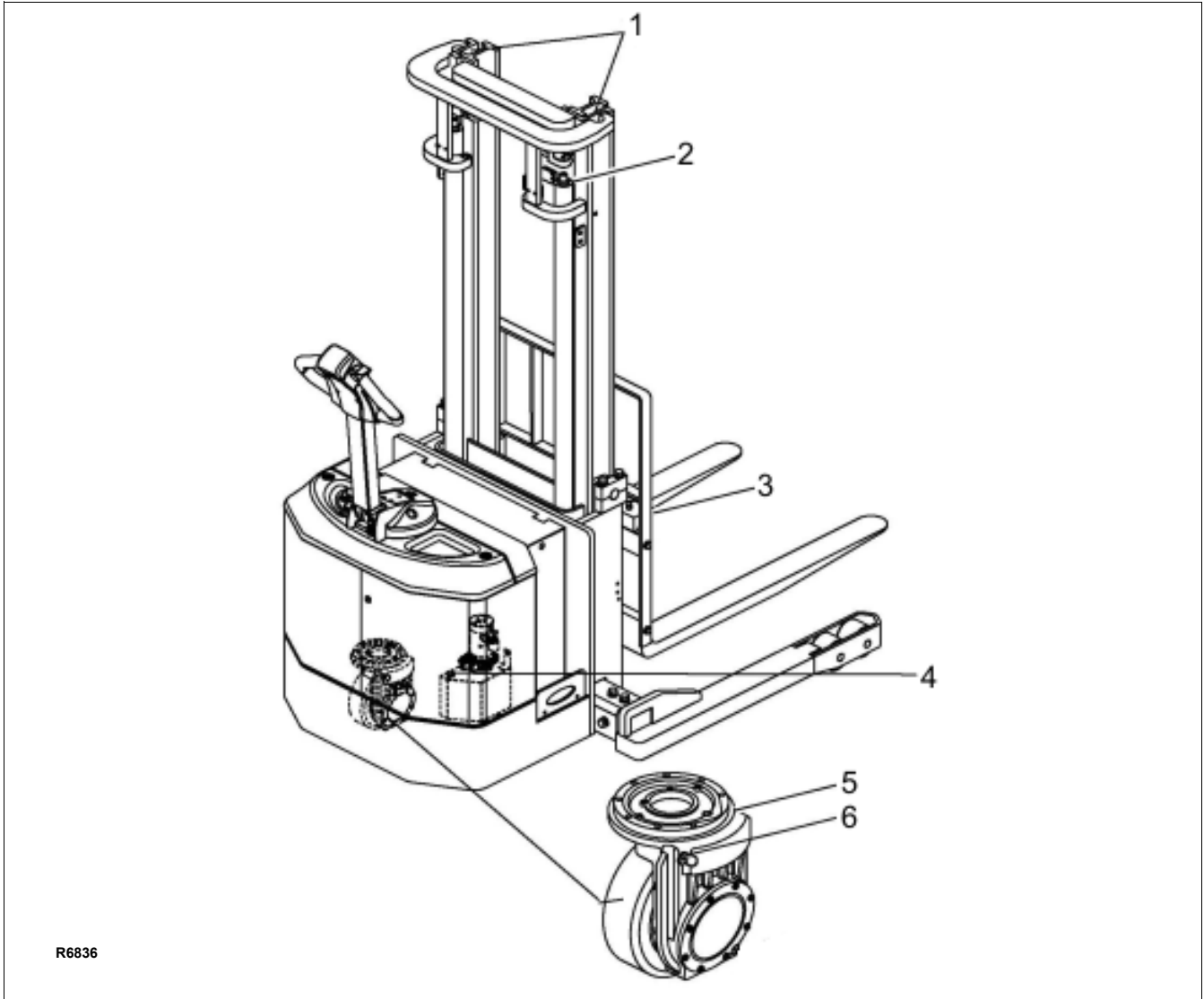

R6836

Figure 3-1 Lubrication Diagram

Table 3-3 Lubrication Chart

FIG 3-2 INDEX NO.	LOCATION	METHOD OF APPLICATION	TYPE (Table 3-3)	APPLICATION OF LUBRICANT
1	Inner & Outer Mast	Brush	No. 2	Full length of channel where rollers operate.
2	Lift Chain	Brush or Spray	No. 4	See Paragraph 3-6.
3	Fork Carriage	Brush	No. 2	Light coating where forks slide
4	Hydraulic Reservoir Capacity-1 quarts	Can	No. 3	With fork carriage fully lowered, fill reservoir with hydraulic oil to 1 inch below opening
5	Pivot Bearing Fitting	Gun	No. 2	Pressure lubricate
6	Transmission Capacity 2 pints	Can	No. 1	Fill to level plug opening

NOTES

SECTION 4 TROUBLESHOOTING

4-1. GENERAL

Use [Table 4-1](#) as a guide to determine possible causes of trouble. The table is divided into five main categories: Truck and Hydraulic System Will Not Oper-

ate: Truck Does Not Operate Forward or Reverse: Trouble With Braking: Trouble With Lifting Or Lowering, and Miscellaneous malfunctions.

Table 4-1 Troubleshooting Chart

MALFUNCTION	PROBABLE CAUSE	CORRECTIVE ACTION
<p>TRUCK AND HYDRAULIC SYSTEM WILL NOT OPERATE Truck will not travel nor will lift system operate.</p>	<p>a. Fuse blown. b. Battery dead or disconnected. c. Keyswitch defective. d. Defective wiring.</p>	<p>Check fuse and replace if necessary. Check battery quick-disconnect plug and check battery voltage. Bypass keyswitch to determine if it is malfunctioning. Check for open circuit. Repair as required.</p>
<p>TRUCK DOES NOT OPERATE FORWARD OR REVERSE Truck does not travel forward or reverse. All other functions operate normally.</p> <p>Truck travels forward but not in reverse.</p> <p>Truck travels reverse but not in forward.</p> <p>Truck travels forward and in reverse at lower speeds; will not travel at high speed.</p>	<p>a. Check all wiring. A loose connection may be the cause of malfunction. b. Defective deadman switch. c. Defective main contactor. d. Defective potentiometer.</p> <p>Defective potentiometer.</p> <p>Defective potentiometer.</p> <p>Defective potentiometer.</p>	<p>Tighten all loose connections before further troubleshooting. Check and replace switch if defective. Check for proper operation and replace if necessary. Check and replace potentiometer if defective. Check and replace potentiometer if defective. Check and replace potentiometer if defective.</p>
<p>TROUBLE WITH BRAKING Truck does not slow with brake, or brake does not engage.</p> <p>Brake will not release.</p>	<p>a. Defective deadman switch. b. Defective electric brake.</p> <p>a. Air gap more than 0.01 in (0.25mm). b. Brake temperature above 281° F (140° C). c. Open brake circuitry or wiring.</p>	<p>Check deadman switch for continuity. If none found when the control arm is in the brake position, replace switch. Adjust or replace brake. Adjust. Allow to cool and check air gap. Make voltage checks.</p>

Table 4-1 Troubleshooting Chart - Continued

MALFUNCTION	PROBABLE CAUSE	CORRECTIVE ACTION
<p>TROUBLE WITH BRAKING - Continued</p> <p>Brake drags.</p> <p>Brake grabs.</p> <p>Abnormal noise and chatter when brake is applied.</p>	<p>a. Air gap less than 0.01 in (0.25mm).</p> <p>b. Defective electric brake.</p> <p>a. Incorrect stopping distance adjustment.</p> <p>b. Defective electric brake.</p> <p>Defective electric brake.</p>	<p>Adjust.</p> <p>Replace.</p> <p>Adjust.</p> <p>Replace.</p> <p>Replace.</p>
<p>TROUBLE WITH LIFTING OR LOWERING</p> <p>Oil sprays or flows from the top of the lift cylinder.</p> <p>Squealing sounds when lifting forks.</p> <p>Forks do not lift to top.</p> <p>Weak, slow or uneven action of hydraulic system.</p> <p>Forks do not lift, pump motor does not run.</p> <p>Forks do not lift, motor runs.</p> <p>Forks lift, but will not go down.</p>	<p>.</p> <p>Defective packing in lift cylinder</p> <p>a. Oil level too low.</p> <p>b. Dry channels in mast.</p> <p>c. Defective mast or carriage rollers</p> <p>a. Oil level too low.</p> <p>b. Load larger than capacity.</p> <p>a. Defective pump or relief valve.</p> <p>b. Worn lift cylinder.</p> <p>c. Load larger than capacity.</p> <p>d. Defective lift motor solenoid.</p> <p>e. Battery charge low.</p> <p>a. Battery is dead or disconnected.</p> <p>b. Defective wiring.</p> <p>c. Defect in electrical system for operating pump motor.</p> <p>Defect in hydraulic system.</p> <p>Defect in hydraulic system</p>	<p>Repair lift cylinder.</p> <p>Identify oil leak.</p> <p>Apply grease.</p> <p>Replace rollers.</p> <p>Add oil to reservoir.</p> <p>Refer to I.D.plate for capacity.</p> <p>Check pressure. Adjust as necessary.</p> <p>Replace cylinder.</p> <p>Refer to I.D.platefor capacity.</p> <p>Replace solenoid on pump motor</p> <p>Charge battery.</p> <p>Check and recharge if required.</p> <p>Check and repair as required.</p> <p>Check lift switch in control head, as well as the solenoid.</p> <p>Check the oil level in the reservoir and the oil lines to the lift cylinder, and repair as required. If normal, check the hydraulic pump, and relief valve. Repair, or adjust.</p> <p>Check lowering control switch in control head and lowering solenoid on valve assembly. Replace as required.</p>

Table 4-1 Troubleshooting Chart - Continued

MALFUNCTION	PROBABLE CAUSE	CORRECTIVE ACTION
<p>TROUBLE WITH LIFTING OR LOWERING - Continued</p> <p>Load will not hold</p>	<p>a. Oil bypassing internally in control valve</p> <p>b. Worn lift cylinder or packing.</p>	<p>Replace valve assembly.</p> <p>Repack cylinder.</p>
<p>Platform does not lift to top. Pump motor runs.</p> <p>Forks creep downward under load when in a raised position.</p>	<p>a. Oil level too low.</p> <p>b. Load larger than capacity.</p> <p>c. Batteries need charging.</p> <p>Leak in hydraulic system, lift cylinder or lowering valve.</p>	<p>Add oil to reservoir.</p> <p>Refer to nameplate on side of mast for maximum load capacity.</p> <p>Change batteries.</p> <p>Check for leaking fitting in hydraulic line and repair as required.</p> <p>Repack lift cylinder or replace valve assembly.</p>
<p>MISCELLANEOUS</p> <p>Steering arm does not return to the upright position.</p> <p>Truck moves forward when arm is pulled down.</p> <p>Steering arm jerks excessively starting or stopping the truck.</p> <p>Drive motor is jerky.</p>	<p>a. Weak return spring.</p> <p>b. Binding.</p> <p>a. Belly-button switch defective.</p> <p>b. Short in control head.</p> <p>Drive wheel worn.</p> <p>Motor internally damaged or worn.</p>	<p>Replace spring.</p> <p>Check and free the binding item. Verify that the cable has not been damaged. Repair or replace as needed.</p> <p>Check for short, and repair or replace as necessary.</p> <p>Check wiring and repair as required.</p> <p>Replace drive wheel if worn to within 3/4 inch of hub.</p> <p>Replace motor.</p>

4-2. CONTROLLER TROUBLESHOOTING

4-2.1. Zapi Handset

A Zapi Handset is available that is designed specifically for use with the Zapi controller. It serves multiple functions of reading diagnostic data, testing truck operation, setting options, adjustments and parameter changes of the controller. The Zapi Handset is available through your Big Lift LLC dealer. If you require dealer location information, contact Big Lift LLC.

Remove the rubber plug from the CNC connector of the controller and plug in the Zapi Handset connector as shown in [Figure 4-1](#).



Figure 4-1 Connecting the Handset

4-2.2. Fault Detection.

4-2.2.1. General

The controller provides diagnostics information to assist technicians in troubleshooting problems. When a fault is detected, an alarm is recorded in the logbook. It has a FIFO (First Input First Output) structure that means the oldest alarm is lost when the database is full and a new alarm occurs. The logbook is composed of alarms with the following information:

- The alarm code
- The times that each alarm occurs consecutively
- The Hour Meter value when the latest event of every alarm occurred

- The invert temperature when the latest event of every alarm occurred.

This function permits a deeper diagnosis of problems as the recent history can be revisited.

4-2.2.2. Logbook Access

To view the alarm logbook proceed as follows:

1. Connect the Zapi Handset, refer to paragraph [4-2.1](#).
2. Press the ROLL down button (1, [Figure 4-2](#)) and the ENTER button (3) at the same time to enter the MAIN MENU.
3. Press the ROLL down button (2) or the ROLL up button (1) to find the ALARMS display.
4. Press the ENTER button (3) to view the alarms.
5. Press the OUT button (6) to exit the alarms.

NOTE: Refer to bigjoesupport.com for the Zapi supplement containing detailed information on alarm codes. There are two versions shown. The PDS uses the Standard version which lists the error by: Alarm Name, Repetitions, Temperature and Hour Meter reading.

6.

4-2.3. Testing Truck Operation.

The Zapi Handset can be used to test certain truck operations as follows:

1. Connect the Zapi Handset, refer to paragraph [4-2.1](#).
2. Press the ROLL down button (1, [Figure 4-2](#)) and the ENTER button (3) at the same time to enter the MAIN MENU.
3. Press the ROLL down button (2) or the ROLL up button (1) to find the TESTER display.
4. Press the ENTER button (3) to view the tests.
5. To verify various switch functions, locate the switch on the display and then operate that function to verify operation
6. Press the OUT button (6) to exit the tests.

4-2.4. Settings and Adjustments

4-2.4.1. Set Options

To set options proceed as follows and refer to [Table 4-2](#):

1. Connect the Zapi Handset, refer to paragraph [4-2.1](#).
2. Press the ROLL up button (1, [Figure 4-2](#)) and the SET up button (5) at the same time to enter the CONFIG MENU.
3. Press the ROLL down button (1) or the ROLL up button (2) to find the SET OPTIONS display.
4. Press the ENTER button (3) to view the options.
5. Press the ROLL down (2) or the ROLL up button (1) to find the option to be changed.
6. Press the SET up button (5) or the SET down button (6) until the desired value setting is reached. The option is now set at the desired value.
7. Press the OUT button (4) to exit the options.

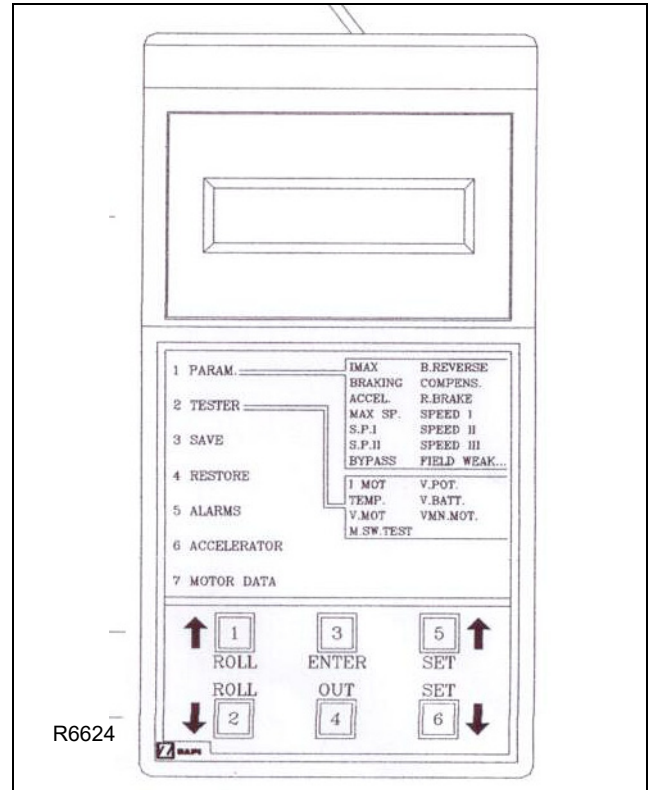

Figure 4-2 Zapi Handset

Table 4-2 Set Options

Parameter	Factory Setting	Description
TILLER switch	HANDLE	This option handles the input CNB#3 (Table 4-5). This input opens when the operator leaves the truck (released). It is connected to a Keyswitch controlled voltage when the operator is present.
SET INPUT #1	OPTION #1	<p>(Standard Version only). This option handles the digital input CNA#15. It can be set as:</p> <ul style="list-style-type: none"> • OPTION #1: CNA is managed as a cutback speed input (SR#1). • OPTION #2: CNA is managed as a digital handbrake input. • OPTION #3: CNA is managed as an inching backward. <p>The input CNA#15 (Table 4-5) can only be used as Aux Lowering request when the MDIPRC is PRESENT.</p> <p>This input must be connected to a Keyswitch controlled voltage. The SR#1 becomes active when CNA#15 (Table 4-5) is open. The inching backward becomes active when the CNA#15 (Table 4-5) is closed to a Keyswitch controlled voltage.</p>

Table 4-2 Set Options - Continued

Parameter	Factory Setting	Description
SET INPUT #2	PRESENT	<p>It can be can be set as:</p> <ul style="list-style-type: none"> • PRESENT: CNA#14 (Table 4-5) is managed as a cutback speed input (SR#2). • OPTION #1: CNA#14 (Table 4-5) is managed as an inching backward. <p>The input CNA#14 (Table 4-5) can only be used as Aux Lifting request when the MDIPRC is PRESENT.</p> <p>This input must be connected to a Keyswitch controlled voltage. The SR#2 becomes active when CNA#14 (Table 4-5) is open. The inching backward becomes active when the CNA#14 (Table 4-5) is closed to a Keyswitch controlled voltage.</p>
SET INPUT #4	OPTION #1	<p>This option handles the digital input CNB#7 (Table 4-5). It can be can be set as:</p> <ul style="list-style-type: none"> • BELLY CNB#7 (Table 4-5) is managed as a Belly Switch input. • BRAKE CNB#7 (Table 4-5) is managed as service brake input. This information can be used also to recognize when the operator is driving with a pressed pedal braking. • EX.HYDRO: CNB#7 (Table 4-5) is managed as Exclusive Hydro. This input must be connected to a Keyswitch controlled voltage. The Belly switch active level is specified on the QUICK INV LOGIC below. <p>The service brake of the exclusive hydro becomes active when CNB#7 is opened.</p>
HOUR COUNTER	RUNNING	<p>This option specifies the hour counter mode. It can be set as:</p> <ul style="list-style-type: none"> • RUNNING: The counter registers travel time only. • key on: The counter registers when the keyswitch is closed.
BATTERY CHECK	Level = 1	<p>This option specifies the handling of the low battery charge detection. It can be set as:</p> <ul style="list-style-type: none"> • Level 0: Nothing happens, the battery charge level is ignored. • Level 1: A BATTERY LOW alarm is raised when the battery level is calculated being less than 10% of the full charge. A BATTERY LOW alarm inhibits the Lifting function. • Level 2: A BATTERY LOW alarm is raised when the battery level is calculated being less than 10% of the full charge. A BATTERY LOW alarm reduces the maximum truck speed down to 24% of the full truck speed then, if the MDI-PRC is absent, inhibits the Lifting function. • Level 3 Equivalent to Level 1; a BATTERY LOW alarm is raised when the battery level is calculated being less than 10% of the full charge. A BATTERY LOW alarm inhibits the Lifting function.
HYDRO KEY ON	OFF	<p>ON/OFF: If this options is programmed ON the traction Inverter manages a hydraulic steering function when the keyswitch is switched ON (only if the AUX OUTPUT #1 option is programmed as HYDRO CONTACT or as WXCLUSIVE HYDRO).</p>
STOP ON RAMP	OFF	<p>Not used.</p>

Table 4-2 Set Options - Continued

Parameter	Factory Setting	Description
AUX OUTPUT #1	BRAKE	<p>This option handles output CNA#3 (Table 4-5). It can be used as:</p> <ul style="list-style-type: none"> • BRAKE: CNA#3 (Table 4-5) drives an electromechanical Brake. • HYDROCOMNT: CNA#3 (Table 4-5) drives the contractor for a hydraulic steering function when the direction input or brake pedal input are active or a movement of the truck is detected. • EX.HYDRO: CNA#3 (Table 4-5) drives the contractor for a hydraulic steering function when the exclusive hydro input is active. • FREE: CNA#3 (Table 4-5) is not used. <p>The current this output can sink is up to 3Adc.</p>
PEDAL BRAKING	NONE	<p>The analog input CNA#18 (Table 4-5) has one of two functions:</p> <ul style="list-style-type: none"> • Pedal Braking input. • Command input for lifting/lowering proportional valves in MDI-PRC version. <p>To turn from the first to the second function is just enough to set PEDAL BRAKING to HNONE.</p> <p>This option handles the analog input CNA#18 (Table 4-5) when used as pedal braking input:</p> <ul style="list-style-type: none"> • ANALOG: With this setting it is possible to modulate the strength of the braking when the accelerator is released. The strength of the braking is proportional to the brake pedal potentiometer connected to this input. When the pedal potentiometer voltage is equal/less than the SET POT BRK MIN, the minimum release braking strength is applied (following the RELEASE BRAKING setting). When the pedal potentiometer voltage is equal/higher than the SET POT BRK MAX, the maximum release braking strength is applied (following the PEDAL BRAKING setting). In the intermediate position, the electrical braking strength is a linear function between the minimum (RELEASED BRAKING) and maximum (PEDAL BRAKING) intensity. When there is also a switch connected to the pedal braking (i.e. SET INPUT #4 to level BRAKE), it must be closed, otherwise the release braking is stuck to the minimum strength disregarding the pedal potentiometer position. • DIGITAL: No pedal potentiometer is expected. Only when both the SET INPUT #4 is Level BRAKE and the brake switch connected to CNB#4 (Table 4-5) is closed, the release electrical braking follows the PEDAL BRAKING setting (maximum strength); in all of the other conditions the release electrical braking follows the RELEASE BRAKING setting (minimum strength). • NONE: The analog input CNA#18 (Table 4-5) is not used for the release braking modulation.
QUICK INVERSION	BELLY	<p>This option specifies the quick inversion mode when the SET INPUT #4 is set BELLY. It can be set as:</p> <ul style="list-style-type: none"> • NONE: The quick inversion function is not managed (no effect when CNB#7 (Table 4-5) switches over). • TIMED: The quick inversion function is timed. • BELLY: The quick inversion function is managed but not timed.

Table 4-2 Set Options - Continued

Parameter	Factory Setting	Description
AUX VOLTAGE #1	100%	This option specifies the percentage of the keyswitch controlled voltage to be applied to the loads on CNA#1 (Table 4-5) (main contactor coil) and CNA#3 (Table 4-5) (electromechanical brake). The voltage modulation is set with a PWM at 1 kHz frequency. After an initial delay of about 1 sec in which the entire keyswitch controlled voltage is applied to the loads, the PWM reduces the voltage at the loads down to the specified percentage.
PERFORMANCE	OPTION #1	This option can be set <ul style="list-style-type: none"> • OPTION#1 • OPTION#2
QUICK INV. LOGIC	OPTION #1	This option specifies the active level for the Belly switch input (CNB#7) <ul style="list-style-type: none"> • OPTION#1: The quick inversion is executed when CNB#7 (Table 4-5) is closed to a Keyswitch controlled voltage. • OPTION#2: The quick inversion is executed when CNB#7 (Table 4-5) is opened from a Keyswitch controlled voltage.
MDI-PRC	ABSENT	This option specifies: <ul style="list-style-type: none"> • PRESENT: The MDI-PRC is connected to the ACO via the CAN Bus: the handling of the Hydraulics is specified on the TRUCK TYPE setting. • ABSENT: The MDI-PRC is not connected to the ACO: the TRUCK TYPE disappears from the SET OPTIONS function list.
MOT SET-UP	OFF	Not used.

4-2.4.2. Adjustments

To change an adjustment proceed as follows and refer to [Table 4-3](#):

1. Connect the Zapi Handset, refer to paragraph 4-2.1.
2. Press the ROLL up button (1, [Figure 4-3](#)) and the SET up button (5) at the same time to enter the CONFIG MENU.
3. Press the ROLL down button (1) or the ROLL up button (2) to find the ADJUSTMENTS display.
4. Press the ENTER button (3) to view the adjustments.
5. Press the ROLL down button (2) or the ROLL up button (1) to find the adjustment to be changed.
6. Press the SET up button (5) or the SET down button (6) until the desired value setting is reached. The adjustment is now set at the desired value.
7. Press the OUT button (4) to exit the adjustments.

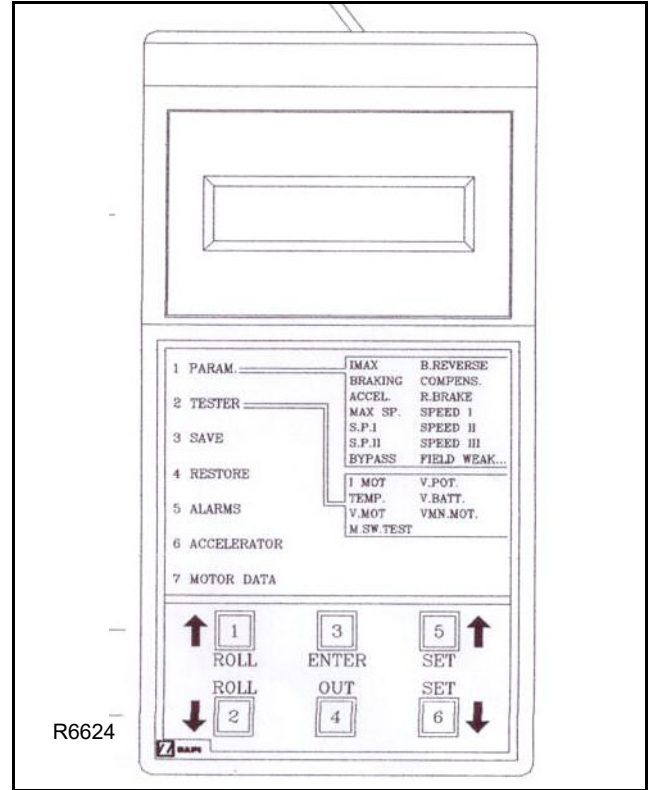

Figure 4-3 Zapi Handset

Table 4-3 Adjustments

Parameter	Factory Setting	Description
SET POT BRK MIN	0.5 V	This setting records the minimum value of braking pedal potentiometer when the braking pedal switch is closed; the procedure is similar to the PROGRAM VACC function. This procedure must be carried out only if the PEDAL BRAKING option is programmed as ANALOG. No adjustment is necessary when PEDAL BRAKING options is programmed as NONE.
SET POT BRK MAX	4.5 V	This setting records the maximum value of braking pedal potentiometer when the braking pedal is fully pressed; the procedure is similar to the PROGRAM VACC function. This procedure must be carried out only if the PEDAL BRAKING option is programmed as ANALOG. No adjustment is necessary when PEDAL BRAKING options is programmed as NONE.
SET BATTERY TYPE	24V	Selects the nominal battery voltage.
ADJUST BATTERY	XX V	Do not modify - Factory adjusted (Fine adjustment of the battery voltage measured by the controller.)
THROTTLE 0 ZONE	9%	Establishes a deadband in the accelerator input curve.

Table 4-3 Adjustments - Continued

Parameter	Factory Setting	Description
THROTTLE X POINT	45%	This parameter together with the THROTTLE Y POINT, changes the characteristic of the accelerator input curve: when the accelerator is de-pressed to X point percent, the corresponding truck speed is Y point percent of the Maximum truck speed. The relationship between the accelerator position and the truck speed is linear between the THROTTLE 0 ZONE and the X point and also between the X point and the maximum accelerator position but with two different slopes (Figure 4-4).
THROTTLE Y POINT	68%	This parameter together with the THROTTLE X POINT, changes the characteristic of the accelerator input curve: when the accelerator is de-pressed to X point percent, the corresponding truck speed is Y point percent of the Maximum truck speed. The relationship between the accelerator position and the truck speed is linear between the THROTTLE 0 ZONE and the X point and also between the X point and the maximum accelerator position but with two different slopes (Figure 4-4).
ADJUSTMENT #01	LEVEL = 5	Adjust the upper level of the battery charge table (Level 0 to 9).
ADJUSTMENT #02	LEVEL = 5	Adjust the lower level of the battery charge table (Level 0 to 9).
LOAD HM FROM MDI	OFF	When set On, the Hourmeter of the Controller is transferred and recorded on the Hourmeter of the Standard MDI (connected on the Serial Link).
CHECK UP DONE	OFF	Turn it On when asked Maintenance service has been executed to cancel the CHECK UP NEEDED warning.
CHECK UP TYPE	NONE	It specifies the handling of the CHECK UP NEEDED warning: <ul style="list-style-type: none"> • NONE: No CHECK UP NEEDED warning. • OPTION#1: CHECK UP NEEDED warning on the handset and MDIPRC after 300 hours. • OPTION#2: Equal to OPTION#1 but Speed reduction after 340 hours. • OPTION#3: Equal to OPTION#2 but the truck definitively stops after 380 hours.

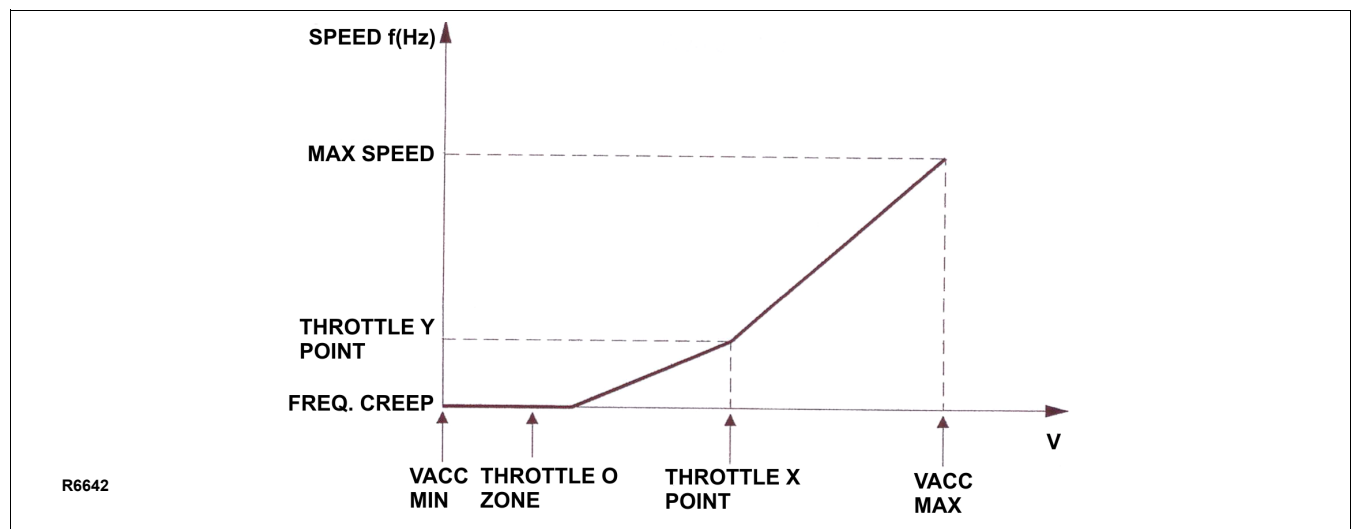

Figure 4-4 Throttle Regulation

4-2.4.3. Parameter Change

To change a parameter proceed as follows and refer to [Table 4-4](#):

1. Connect the Zapi Handset, refer to paragraph [4-2.1](#).
2. Press the ROLL down button (1, [Figure 4-5](#)) and the ENTER button (3) at the same time to enter the MAIN MENU.
3. Press the ROLL down button (1) or the ROLL up button (2) to find the PARAMETER CHANGE display.
4. Press the ENTER button (3) to view the parameters.
5. Press the ROLL down button (2) or the ROLL up button (1) to find the parameter to be changed.
6. Press the SET up button (5) or the SET down button (6) until the desired value setting is reached. The parameter is now set at the desired value.
7. Press the OUT button (4) to exit the parameters.

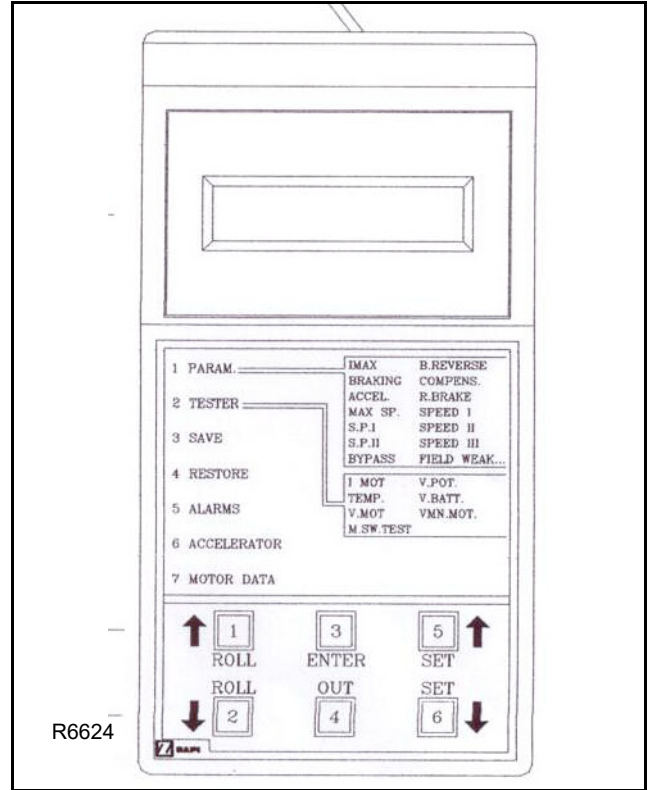

Figure 4-5 Zapi Handset

Table 4-4 Parameter Adjustments

Parameter	Factory Setting	Description
ACCELER. DELAY	LEVEL = 8	Level 0 to 9. It determines the acceleration ramp. At Level 9 the truck takes a long time to accelerate.
RELEASE BRAKING	LEVEL = 5	Level 0 to 9. It controls the deceleration ramp when the travel request is released. At Level 9 the truck brakes abruptly.
INVERS. BRAKING	LEVEL = 4	Level 0 to 9. It controls the deceleration ramp when the direction switch is inverted during travel. At Level 9 the truck brakes abruptly.
PEDAL BRAKING	LEVEL = 9	Level 0 to 9. It controls the deceleration ramp when the travel request is released and the brake pedal switch is pressed to its maximum. At Level 9 the truck brakes abruptly.
SPEED LIMIT BRK	LEVEL = 1	Level 0 to 9. It controls the deceleration ramp when the accelerator has turned down but not completely released. At Level 9 the truck decelerates abruptly.
BRAKE CUTBACK	LEVEL = 5	Level 0 to 9. It controls the deceleration ramp when the a speed reduction input becomes active and the motor slows down. At Level 9 the truck decelerates abruptly.
MAX SPEED FORW	100 Hz	Typically from 90 Hz to 160 Hz. It determines the maximum speed in forward direction.
MAX SPEED BACK	100 Hz	Typically from 90 Hz to 160 Hz. It determines the maximum speed in backward direction.

Table 4-4 Parameter Adjustments - Continued

Parameter	Factory Setting	Description
CUTBACK SPEED	100%	Typically from 10% to 100%. It determines the percentage of the max speed applied when the cutback switch 1 (SR#1 on CNA#15 (Table 4-5) is active. When set to 100% the speed reduction is ineffective.
CUTBACK SPEED 2	37%	Typically from 10% to 100%. It determines the percentage of the max speed applied when the cutback switch 2 (SR#2 on CNA#14 (Table 4-5) is active. When set to 100% the speed reduction is ineffective.
HS CUTBACK	100%	Typically from 10% to 100%. It determine the percentage of the max speed applied when the Hard & Soft function (H&S switch on CNB#4 (Table 4-5) is active. When set to 100% the speed reduction is ineffective.
FREQUENCY CREEP	5.00 Hz	Hz value. This is the minimum speed applied when the forward or reverse switch is closed, but the accelerator at its minimum. In the ACO sense Coils this setting is higher equal than 5 Hz.
RPM CREEP	100%	A Percentage value. Set to 100% and not Used.
MAXIMUM CURRENT	96%	It specifies the percentage of the absolute current (150A) at which the current will be limited. Normally MAXIMUM CURRENT is 100%. DO NOT CHANGE.
INCHING SPEED	0 Hz	Hz value. It determines the speed when the “Inching function” is active.
INCHING TIME	LEVEL = 0	Level 0 to 9. It determines the duration time when the “Inching function” is active.
AUXILIARY TIME	1	Time units value (seconds). For the encoder version, it determines the time duration (in seconds) in which the the frequency was arrived to zero.
ANTIROLLBACK	80%	A Percentage of the Maximum Current. This setting increases the phase current when low frequency during starting operation. It is used to push up, in feedforward way, the torque when it is not possible to control the flux, in feedback way, because of the low frequency.

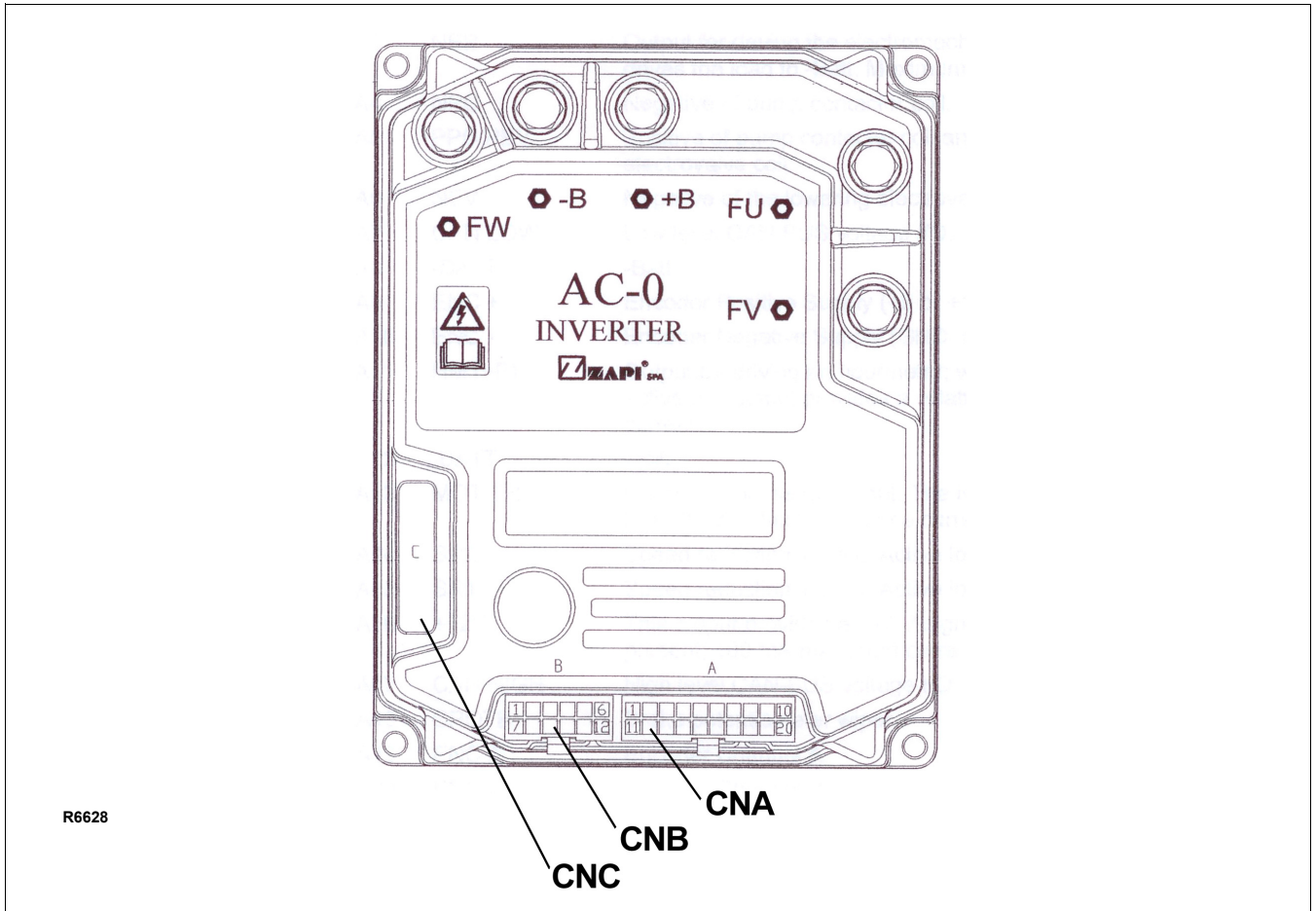

Figure 4-6 Zapi Controller Connectors

Table 4-5 Zapi Controller Connector Pins

CNA Connector		
PIN	ABBREVIATION	DESCRIPTION
CNA#1	NMC	Negative of main contactor coil.
CNA#2	PMC	Positive of main contactor coil.
CNA#3	NEB	Output for driving the electromechanical brake coil; drives the load to -Batt. Maximum current: 3 A.
CNA#4	NPC	Negative of pump contactor soil.
CNA#5	PPC/PEV	Positive of pump contactor coil and lowering electrovalve coil.
CNA#6	NEV	Negative of the lowering electrovalve coil.
CNA#7	CAN LOW	Low level CAN-BUS voltage I/O.
CNA#8	-BAT	-Bat.
CNA#9	ENC+	Encoder Positive Supply (+5 or +12 Vdc)
CNA#10	ENC-	Encoder Negative Supply (GND to minus battery)
CNA#11	HM(+B)	Output for driving an hourmeter; when the hourmeter is active this output provides a +Batt signal; 3 maximum current.

Table 4-5 Zapi Controller Connector Pins - Continued

CNA Connector - Continued

PIN	ABBREVIATION	DESCRIPTION
CNA#12	-BATT	-Batt.
CNA#13	MOT TH	Motor thermal sensor input. The internal pull-up is a fixed 2mA (Max 5V) source current.
CNA#14	SR2	Speed reduction 2 input. Active low (switch opened).
CNA#15	SR1	Speed reduction 1 input. Active low (switch opened).
CNA#16	+12V	This output provides a +12V signal for the MDI PRC, it present; mA maximum current.
CNA#17	CAN HIGH	High level CAN-BUS voltage I/O.
CNA#18	CPOTB	Brake potentiometer wiper.
CNA#19	ENC A	Encoder Channel A.
CNA#20	ENC B	Encoder Channel B.

CNB Connector

CONNECTOR PIN	ABBREVIATION	DESCRIPTION
CNB#1	KEY SW	Connected to the power supply through a microswitch (KEY) with a 6.3-10 A fuse in series (this could be mounted on the AC-0 cover).
CNB#2	CM	Common for FW/BW/SR1/SR2/TILLER/H&S/BELLY/LIFTING/ LOWERING microswitches. This connection supplies a keyswitch voltage level.
CNB#3	TILLER SW	Tiller request input. Must be connected to the tiller microswitch, active high.
CNB#4	H&S SW	Hard & Soft request input. Must be connected to the Hard & Soft microswitch, active high.
CNB#5	BACKWARD SW	Backward direction request input. Must be connected to the backward direction microswitch, active high.
CNB#6	FORWARD SW	Forward direction request input. Must be connected to the forward direction microswitch, active high.
CNB#7	BELLY SW	Quick inversion function input; must be connected to the Belly microswitch; it is active high.
CNB#8	LOWERING SW	Lowering request input, active high.
CNB#9	LIFTING SW	Lifting request input, active high.
CNB#10	CPOT	Lifting request input, active high.
CNB#11	NPOT	Negative of accelerator unit, tested for wire disconnection diagnosis.
CNB#12	PPOT	Potentiometer positive: 10V output; keep load >1kΩ.

Table 4-5 Zapi Controller Connector Pins - Continued

CNC Connector		
CONNECTOR PIN	ABBREVIATION	DESCRIPTION
CNC#1	PCLRxD	Positive serial reception.
CNC#2	NCLRxD	Negative serial reception.
CNC#3	PCLTxD	Positive serial transmission.
CNC#4	NCLTxD	Negative serial transmission.
CNC#5	GND	Negative console power supply.
CNC#6	+12V	Positive console power supply.
CNC#7	FLASH	Must be connected to C8 for the Flash memory programming (if used).
CNC#8	FLASH	Must be connected to C7 for the Flash memory programming (if used).

NOTES

SECTION 5 STEERING ARM, CONTROL HEAD AND COMPARTMENT

5-1. CONTROL HEAD

5-1.1. Cap Assembly Removal.

1. Turn off the key switch and disconnect the batteries.

2. Remove four screws, lift up cap assembly and disconnect harness from harness.

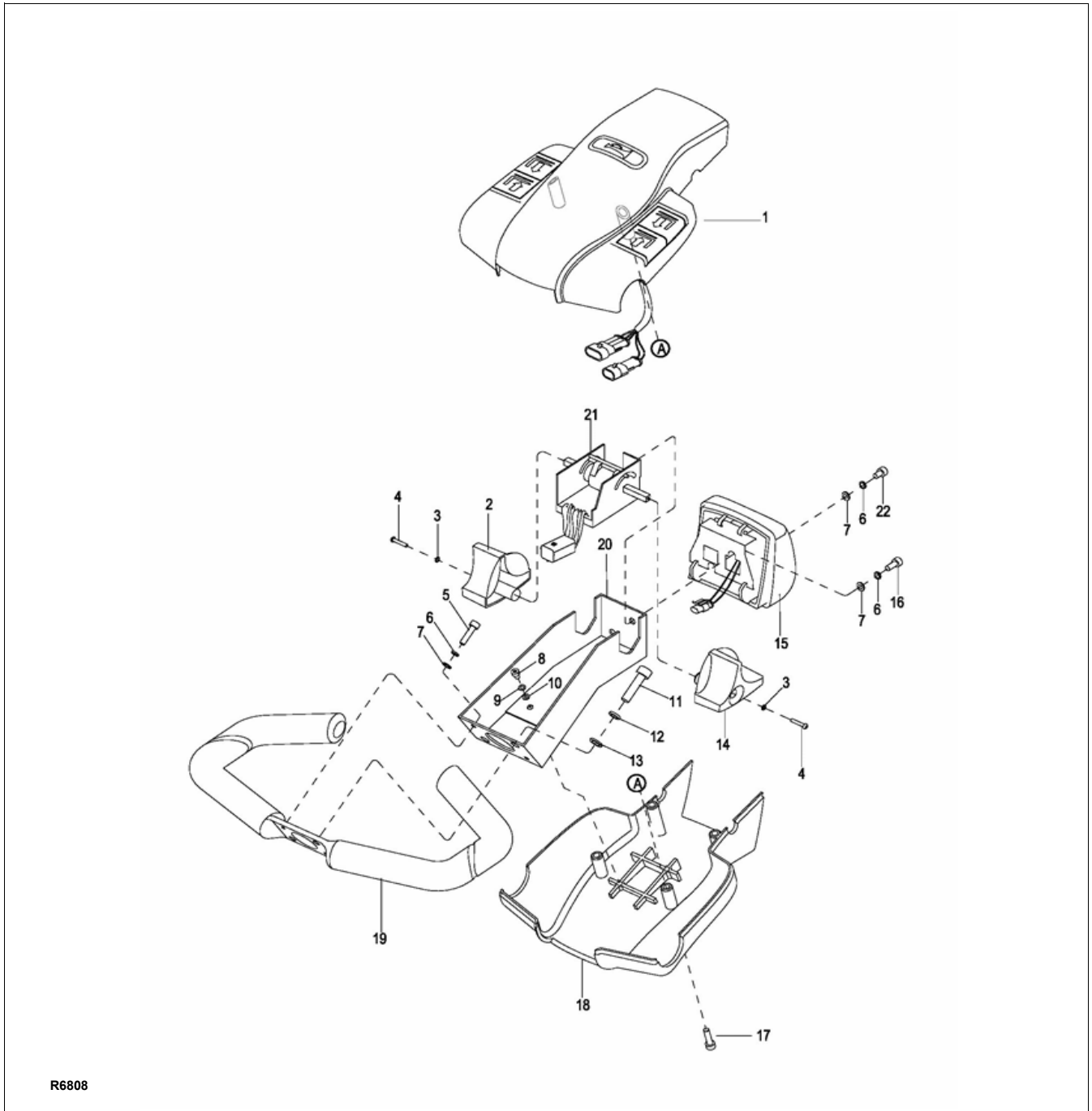

R6808

Figure 5-1 Control Head

5-1.2. Cap Assembly Installation.

1. Hold cap assembly in place and connect harness (23) to harness.

2. 2. Position cap assembly on control head and secure with four screws.
 3. 3. Reconnect the batteries and turn on the key switch.

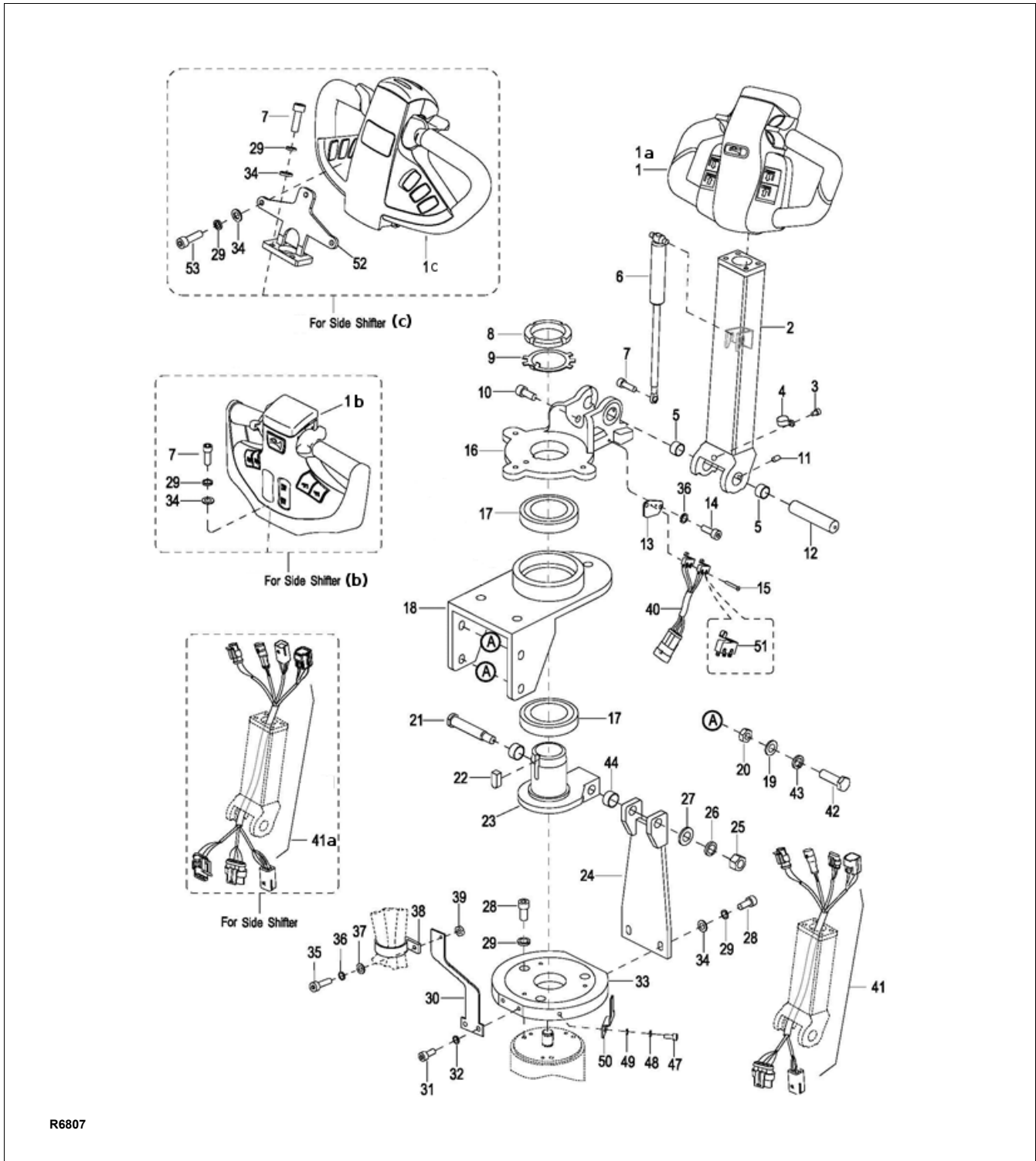

Figure 5-2 Steering Arm

5-1.3. Control Head Removal

1. Remove the cap assembly as described in paragraph 5-1.1.
2. Disconnect harness from potentiometer and reversing switch.
3. Remove two screws, two lock washers and two flat washers.

WARNING: When removing the control head in the following steps, be sure to hold it in place until the control harness is disconnected.

4. Remove two screws, two washers and two flat washers.
5. Remove the control head and handle

5-1.4. Control Head Installation

1. Hold control head and handle in place and install two screws, two washers and two flat washers.
2. Install two screws, two lock washers and two flat washers.
3. Reconnect harness to potentiometer and reversing switch.
4. Install the cap assembly as described in paragraph 5-1.2.

5-1.5. Speed Potentiometer Replacement.

1. Remove the cap assembly as described in paragraph 5-1.1.
2. Disconnect harness from potentiometer.
3. Remove screw, washer and control knob from potentiometer.
4. Remove screw, washer and control knob from other side of potentiometer.
5. Remove screw, lock washer and flat washer.

6. Remove screw , lock washer and flat washer and remove potentiometer from bracket.
7. Position new potentiometer in bracket and secure with screw, lock washer and flat washer.
8. Install screw, lock washer and flat washer.
9. Install control knob on potentiometer and secure with screw , and washer.
10. Install control knob on the other side of potentiometer and secure with screw, and washer.
11. Connect harness to potentiometer.
12. Install the cap assembly as described in paragraph 5-1.2.

5-1.6. Belly-Button Switch Replacement.

1. Remove the cap assembly as described in paragraph 5-1.1.
2. Disconnect harness from reversing switch.
3. Remove screw, lock washer and flat washer.
4. Remove screw , lock washer and flat washer and remove switch assembly from bracket.
5. Remove pin and bracket, and spring from button.
6. Remove two pins and switch assembly from bracket.
7. Position the new switch assembly in bracket and secure with two pins.
8. Position bracket in button and install pin.
9. Position switch assembly on bracket and secure with two screws.
10. Reconnect harness to reversing switch
11. Install the cap assembly as described in paragraph 5-1.2.

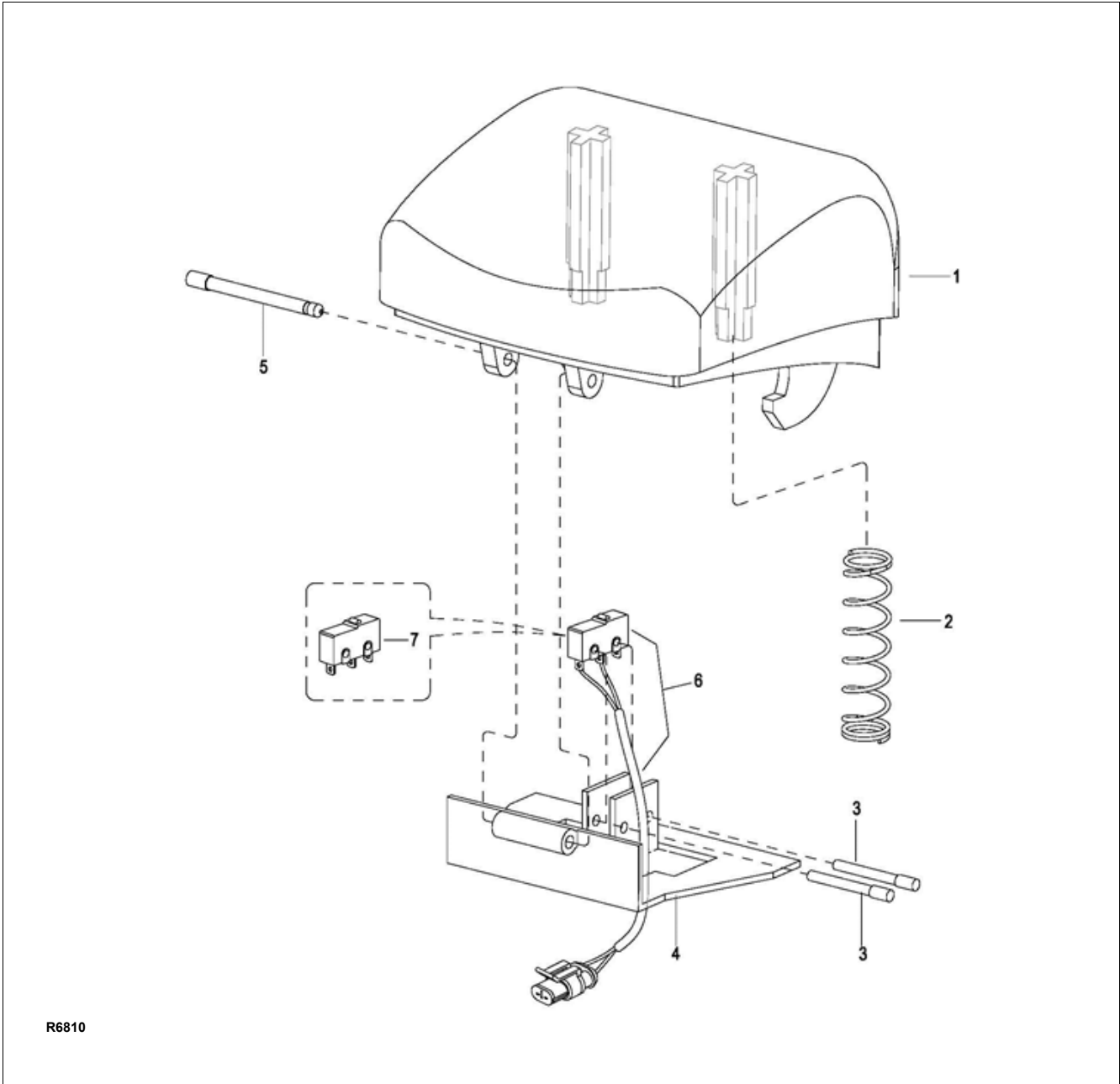

R6810

Figure 5-3 Emergency Reverse Switch Assembly

5-1.7. Horn Switch Replacement.

1. Remove the cap assembly as described in paragraph 5-1.1.
2. Remove three screws, bracket and springs.
3. Remove two pins and defective switch from bracket.
4. Unsolder harness from defective switch and connect it to the new switch.
5. Position the new switch in bracket and secure with two pins.
6. Position bracket in cover and secure with three screws .
7. Install the cap assembly as described in paragraph 5-1.2.

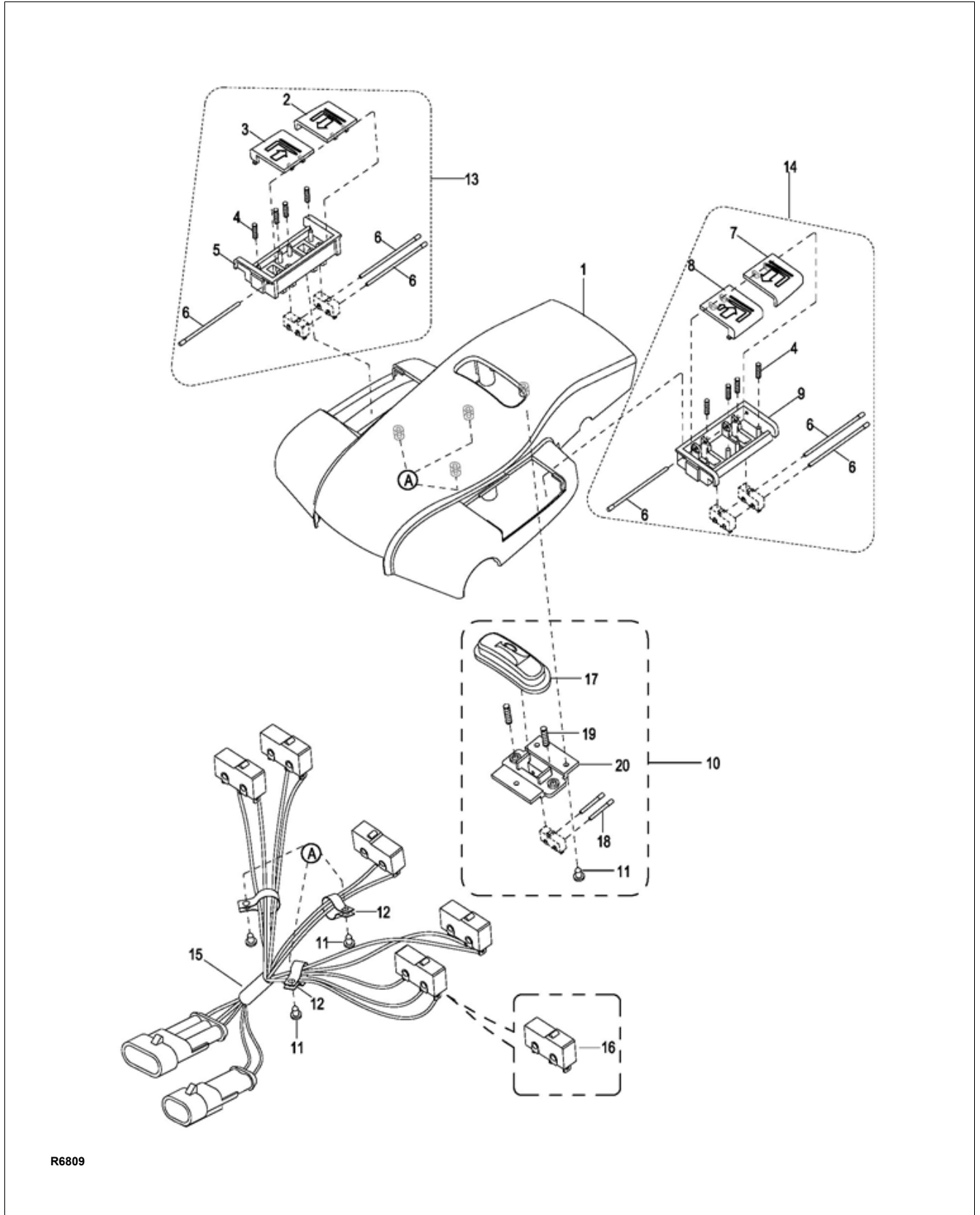

R6809

Figure 5-4 Cap Assembly

5-1.8. Lift and Lower Switch Replacement.

1. Remove the cap assembly as described in paragraph 5-1.1.
2. Remove switch assembly from cap.
3. Remove pin securing buttons and remove the buttons.
4. Remove two pins, two switches and four springs from bracket.
5. Unsolder harness from defective switch.
6. Solder the harness to new switch.
7. Position the new switches and four springs in bracket and secure with two pins.
8. Position switch assembly in cover and secure with pin.
9. Install the cap assembly as described in paragraph 5-1.2.

5-2. STEERING ARM

5-2.1. Return Spring Replacement.

The steering arm gas return spring is replaced while the steering arm is in the upright position.

1. Turn off the key switch and disconnect the batteries.
2. Remove three screws and middle cover.
3. Secure the steering arm in the upright position.
4. Remove screw and free the gas return spring from bracket.
5. Pull downward on the gas return spring to free it from its seat inside steering arm.
6. Position the new gas return spring inside the steering arm being sure it fully engages its seat.
7. Position the opposite end of the gas return spring on bracket and install screw.
8. Install middle cover and secure with three screws.

9. Reconnect the batteries and turn on the key switch.

5-2.2. Steering Arm Removal.

1. Turn off the key switch and disconnect the batteries.
2. Disconnect harness from harness.
3. Attach a hoist to steering arm.
4. Remove screw, shaft and the steering arm.

5-2.3. Steering Arm Installation.

1. Position steering arm over the bracket and secure with the shaft and screw.
2. Reconnect harness from harness.
3. Reconnect the batteries and turn on the key switch.

5-3. COMPARTMENT COVERS

5-3.1. Removal.

1. Turn off the key switch and disconnect the batteries.
2. Remove three screws and middle cover.
3. Remove three screws and upper cover.
4. Remove two screws and two washers.
5. Open covers

5-3.2. Installation.

1. Close covers.
2. Install two screws and two washers.
3. Install upper cover and secure with three screws.
4. Install middle cover and secure with three screws.
5. Reconnect the batteries and turn on the key switch.

SECTION 6 BRAKE SERVICING

6-1. BRAKES.

The brake system consists of a drive motor mounted brake. This brake is spring applied and electrically released.

6-1.1. Air Gap Adjustment.

The "air gap" is the distance between the magnet body and the rotor plate with the brake applied. As the brake pads and rotor wear normally, the air gap will increase and should be readjusted when it measures more than 0.25 mm.

NOTE: If the air gap measures more than 0.25 mm, the brake may not release properly. Air gap adjustment can be performed as long as the brake pads and rotor function properly or until the adjustable spacer threads are fully engaged (adjustment limit reached).

1. Block load wheels.
2. Remove the compartment covers as described in paragraph 5-3.
3. Using low pressure air, remove any dirt between armatures and magnet body.
4. Using standard feeler gauges, check the gap between the magnet body and the rotor plate. The gap should be 0.25 mm.
5. If necessary, refer to [Figure 6-1](#) and adjust the gap as follows:
 - a. Loosen the three mounting screws by half a turn.
 - f. The threaded air gap adjusting nuts can then be screwed into Magnet Body by turning counterclockwise.
 - g. Turn the three mounting screws clockwise until the gap measures 0.012" (0.25 mm).
 - h. The threaded air gap adjusting nuts are then screwed clockwise until they bottom.
 - i. Finally tighten the three mounting screws to 52 in-lb (6 Nm).

j. Recheck the gap.

11. Remove load wheel blocks and check operation.
12. Install the compartment covers as described in paragraph 5-3.

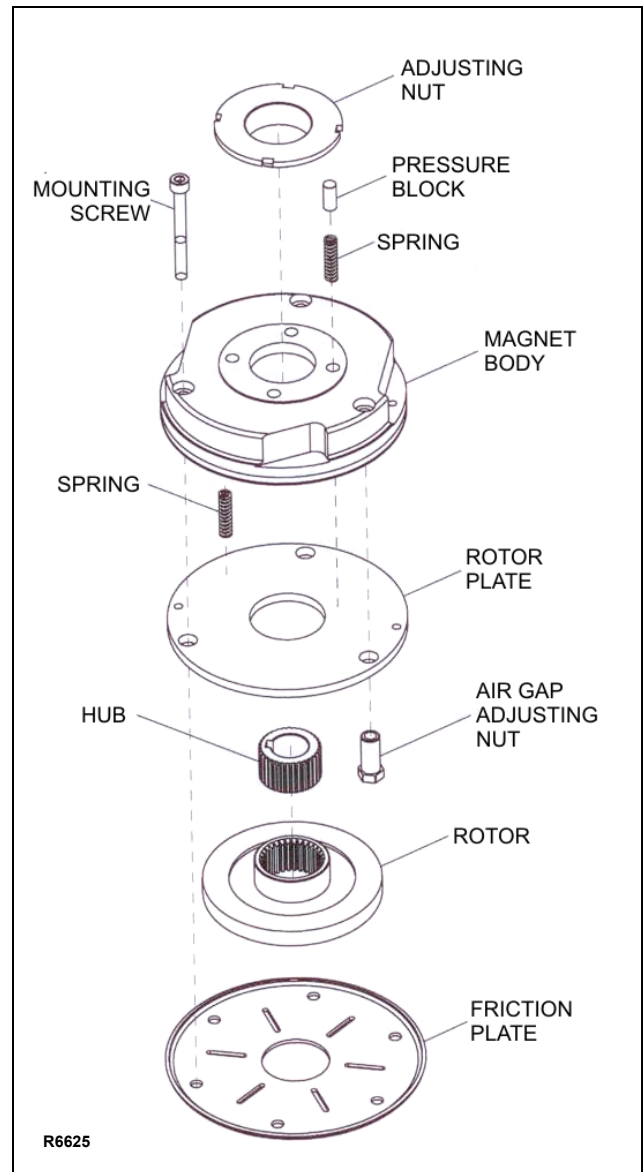

Figure 6-1 Brake Assembly

6-1.2. Stopping Distance Adjustment.

The stopping distance of the truck should require minimal adjustment. However, this distance should be checked with each planned maintenance.

Using an unloaded truck, run truck to its top speed on an even dry concrete surface. Move control handle into the lower braking position. Measure length of braking path from the actuation point of the brakes until the truck has stopped. The actual length of the braking path should be between approximately 1.5 - 2.5 ft (0.5-0.7 m).

To adjust stopping distance, proceed as follows:

1. Block load wheels.
2. Remove the compartment covers as described in paragraph 5-3.
3. Rotate the adjusting nut (Figure 6-1) clockwise to SHORTEN the stopping distance or counterclockwise to LENGTHEN the stopping distance.
4. Remove load wheel blocks and check operation.

5. Install the compartment covers as described in paragraph 5-3.

6-1.3. Brake Assembly Replacement

1. Block load wheels.
2. Remove the compartment covers as described in paragraph 5-3.
3. Disconnect electric brake from harness.
4. Remove the three mounting screws (Figure 6-1) and the brake.
5. Place the new brake into position and secure with the three mounting screws.
6. Finally tighten the three mounting screws to 52 in-lb (6 Nm).
7. Reconnect electric brake from harness.
8. Remove load wheel blocks and check operation.
9. Install the compartment covers as described in paragraph 5-3.

SECTION 7 TRANSMISSION, DRIVE WHEEL, LOAD WHEEL

7-1. Drive Wheel.

1. Turn off the key switch and disconnect the batteries.
2. Remove the compartment covers as described in paragraph 5-3.
3. Loosen but do not remove the five nuts.
4. Jack up the truck so the drive wheel is off the ground; then securely block the truck to prevent movement.
5. Remove the five nuts five washers and drive wheel from the transmission.
6. Install new drive wheel in reverse order of removal.
7. Install the compartment covers as described in paragraph 5-3.
8. Reconnect the batteries and turn on the key-switch.

7-2. Transmission.

1. Turn off the key switch and disconnect the batteries.
2. Remove the compartment covers as described in paragraph 5-3.
3. Remove the brake as described in paragraph 6-1.3.
4. Remove the drive wheel as described in paragraph 7-1.
5. Remove two screws, two lock washers and two flat washers.
6. Note routing of cables to ensure proper installation.
7. Tag the cables connected to the drive motor; then disconnect these cables from the drive motor.
8. Support the transmission and remove the six screws, six lock washers and six flat washers.
9. Slowly lower the transmission out the bottom of the frame.
10. Install new transmission by reversing the steps above.

7-3. Load Wheel.

7-3.1. Removal

1. Raise forks.
2. Turn off the key switch and disconnect the batteries.
3. Block the drive wheel to prevent the truck from rolling.
4. Jack up the forks to raise the load wheels off the floor. Securely block the forks in the raised position by positioning supports under both fork tips.
5. Remove screw or retaining ring securing shaft.

NOTE: When shaft is removed, load wheel will drop free.

6. Remove shaft, load wheel and washers.
7. Remove bearings from load wheel.

NOTE: Inspect the load wheel assembly. If the load wheel is worn within 1/8" of the metal sleeve, or is cracked or damaged, replace the entire load wheel and bearing assembly. Big Lift LLC recommends that both load wheel assemblies be replaced at the same time. This ensures level and safe operation of the lift truck.

7-3.2. Load Wheel Installation

NOTE: Adjustable straddle shown, fixed straddle similar.

1. Install bearings in load wheel.
2. Position load wheel and washers in straddle.
3. Install shaft and secure with screw or retaining ring.
4. Remove blocking from under the truck.
5. Lower the forks.
6. Reconnect the batteries and turn on the key-switch.

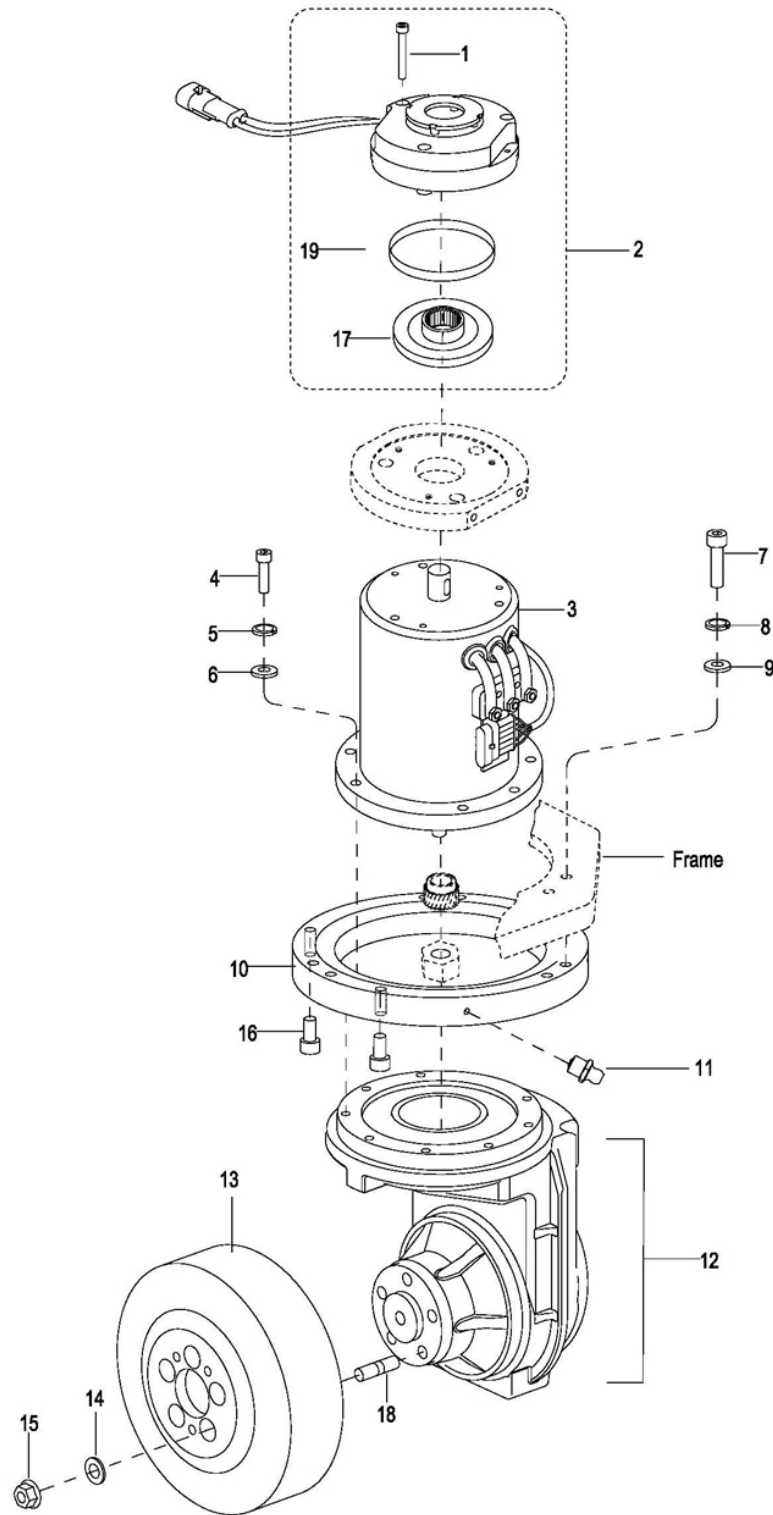

R6811

Figure 7-1 Transmission, Motor, Brake Assembly

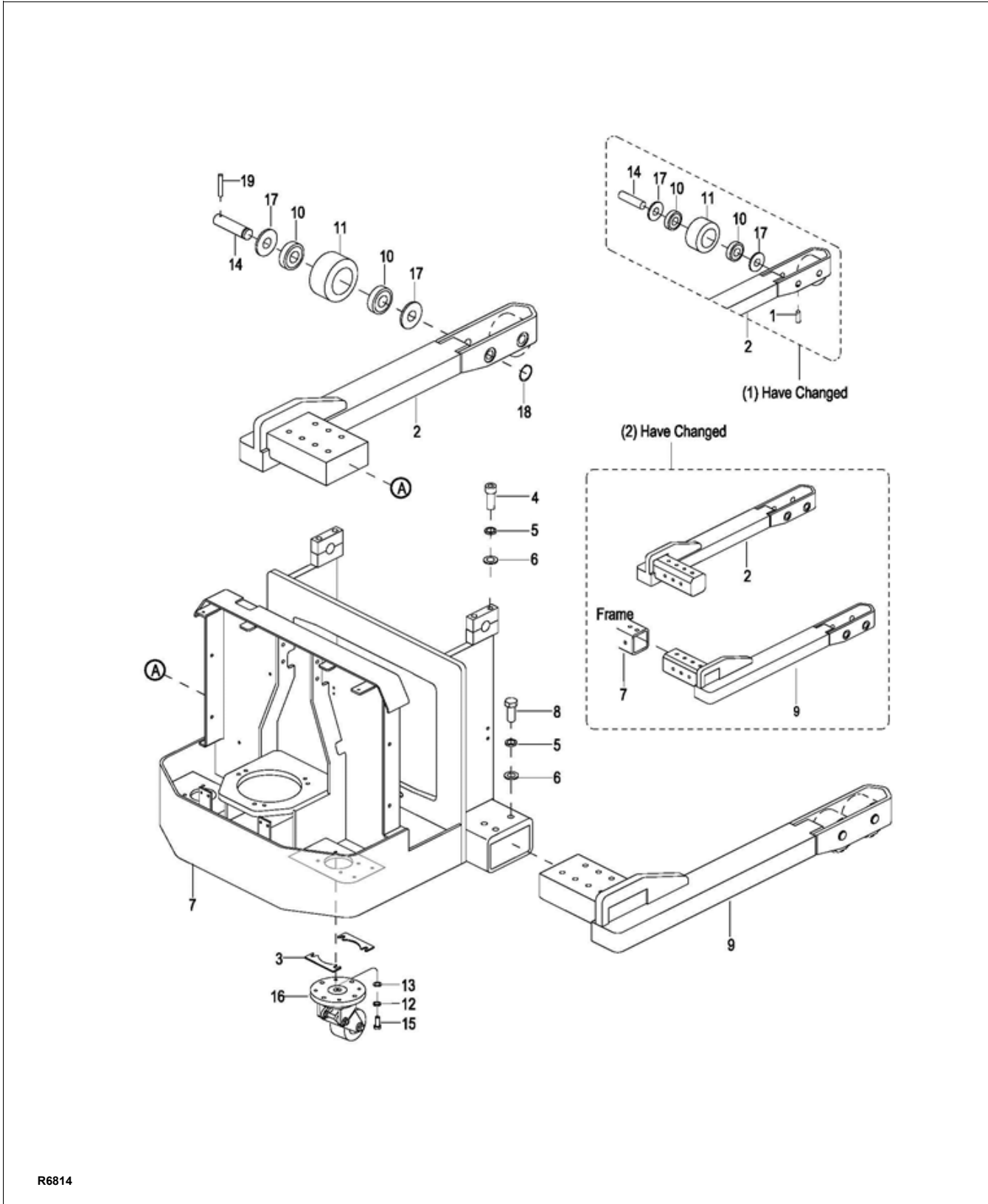

R6814

Figure 7-2 Adjustable Straddle

NOTES

SECTION 8 ELEVATION SYSTEM SERVICING

8-1. GENERAL.

The elevation system includes the outer mast, inner mast, lift linkage, lift chains, lift cylinder and ram head.

8-2. LIFT CHAIN LENGTH ADJUSTMENT.

8-2.1. Telescopic

1. Fully lower the fork carriage.
2. Turn off the key switch and disconnect the batteries.

WARNING: Before attempting any adjustment, make certain power is disconnected.

3. Loosen jam nuts (2, Figure 8-1), located above the mount of outer mast (20, Figure 8-2), to allow for adjustment of middle jam nut.
4. Break the lower jam nuts (2, Figure 8-1), located below the mount of outer mast, free from the middle jam nuts (2).
5. Take up slack in both lift chains with middle jam nut (2). Strive for equal tension on both chains.
6. Align anchors (1) so each clevis pin (4) is parallel to outer mast cross (20, Figure 8-2).

CAUTION: At least 3 full threads must be present below lower nut (2, Figure 8-1) after adjustment.

7. Tighten jam nuts securely while maintaining alignment of clevis pins (4).
8. Reconnect the batteries and turn on the key-switch.
9. Test chain by operating carriage. If slack is still apparent, repeat above procedure

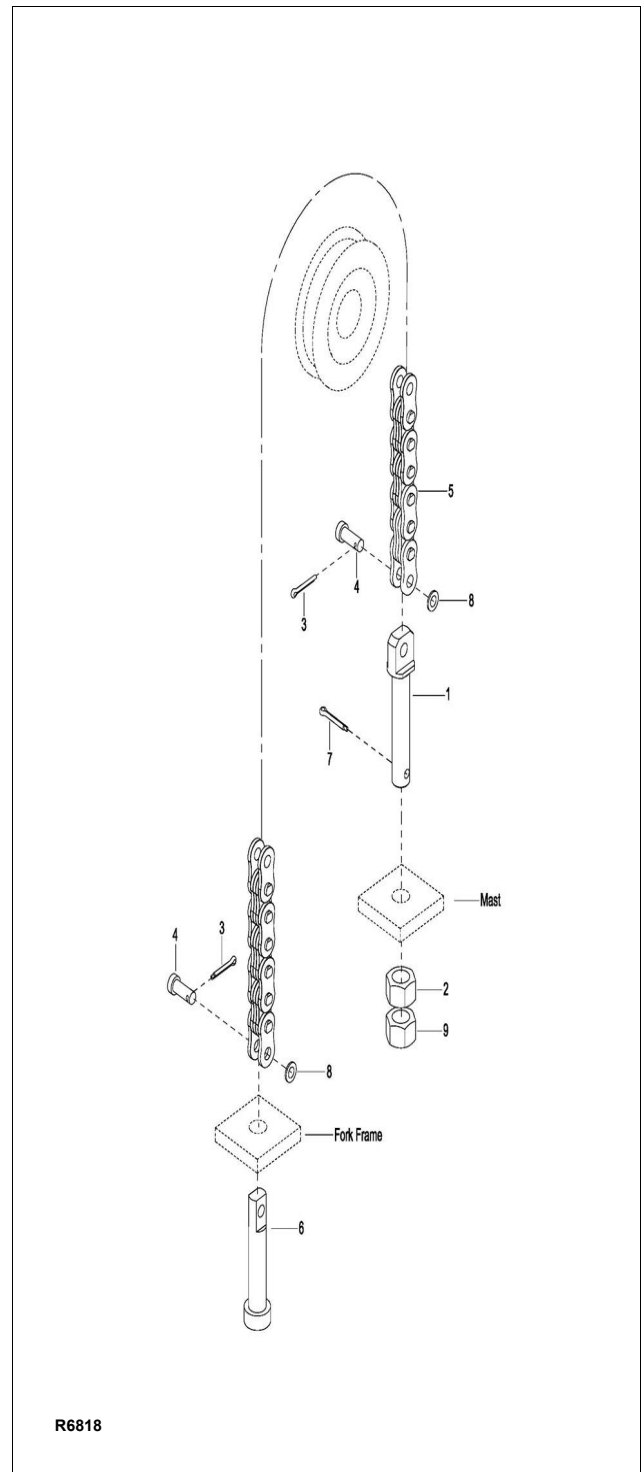
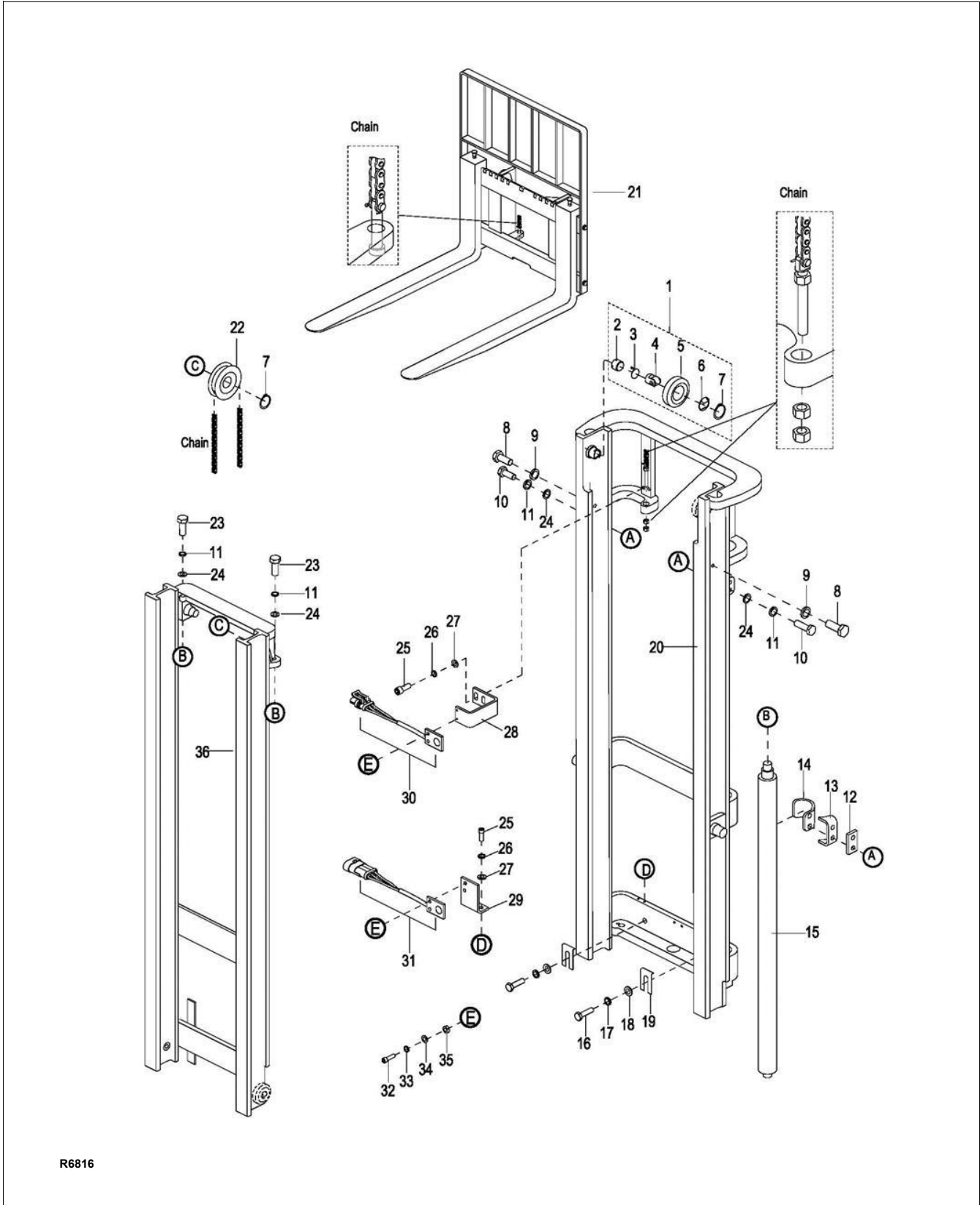

Figure 8-1 Chain Assembly



R6816

Figure 8-2 Elevation System (Telescopic)

8-2.2. TRIMAST Free Lift Chain

1. Fully lower the lift carriage.
2. Turn off the key switch and disconnect the batteries.

WARNING: Before attempting any adjustment, make certain power is disconnected.

3. Loosen jam nuts located the above the mounts of cylinder, to allow for adjustment of middle jam nut.
4. Break the lower jam nuts located below the mounts of cylinder free from the middle jam nuts.
5. Take up slack in both lift chains with middle jam nut. Strive for equal tension on both chains.
6. Align anchors (1) so each clevis pin (4) is parallel to inner mast.

CAUTION: At least 3 full threads must be present below lower nut after adjustment.

7. Tighten jam nuts securely while maintaining alignment of clevis pins.
8. Reconnect the batteries and turn on the key-switch.
9. Test chain by operating carriage. If slack is still apparent, repeat above procedure.

8-2.3. TRIMAST Secondary Lift Chain

1. Fully lower the lift carriage.
2. Turn off the key switch and disconnect the batteries.

WARNING: Before attempting any adjustment, make certain power is disconnected.

3. Loosen jam nuts, the mount of outer mast, to allow for adjustment of middle jam nut.

4. Break the lower jam nuts, located below the mount of outer mas, free from the middle jam nuts.
5. Take up slack in both lift chains with middle jam nut. Strive for equal tension on both chains.
6. Align anchors so each clevis pin is parallel to the outer mast.

CAUTION: At least 3 full threads must be present below lower nut after adjustment.

7. Tighten jam nuts securely while maintaining alignment of clevis pins.
8. Reconnect the batteries and turn on the key-switch.
9. Test chain by operating carriage. If slack is still apparent, repeat above procedure.

8-3. LIFT CHAIN WEAR INSPECTION.

Both lift chains should be replaced when either chain is worn enough to increase it's length by 3% or more. To make this determination proceed as follows.

Using a section of chain that sees the most frequent operation over the chain sheaves, isolate a vertical portion under tension from the weight of carriage and forks.

Measure the distance between pin centers on 20 vertical links. If the section measures 12.88" or more, the chain should be replaced.

New chain anchor pins should be installed when chains are replaced. Never replace a partial section of chain and never repair chain. Refer to paragraph 8-4. when installing new chain.

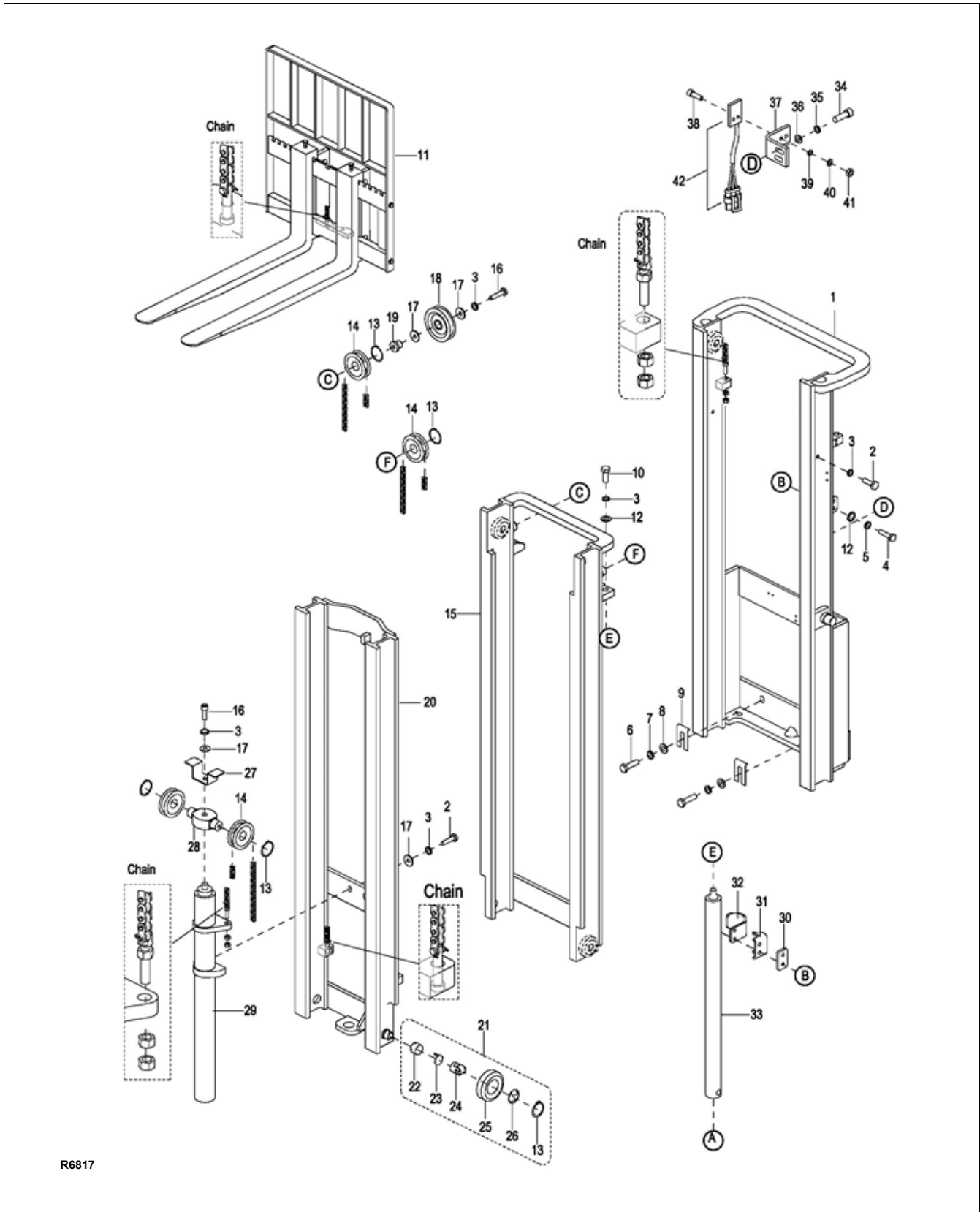

R6817

Figure 8-3 Mast (TRIMAST)

8-4. LIFT CHAIN REPLACEMENT.

8-4.1. Telescopic

1. With the lift truck wheels securely blocked, raise the forks approximately three feet from floor and position blocks or strong supports under inner mast.
2. Lower inner mast onto the support. Check that arrangement is secure before proceeding.
3. Turn off the key switch and disconnect the batteries.

WARNING: Before attempting any replacement, make certain power is disconnected.

4. Remove cotter pin and clevis pin connecting chain to chain anchor at the lift carriage.
5. Remove cotter pin and clevis pin connecting chain to chain anchor at the outer mast.
6. Remove chain from sheave.
7. Position new chain on sheave.
8. Secure chain to chain anchor at the outer mast with clevis pin and cotter pin.
9. Connect the opposite end of chain to chain anchor at the lift carriage with clevis pin and cotter pin.
10. Adjust the chains according to paragraph 8-2..
11. Reconnect the batteries and turn on the keyswitch

8-4.2. TRIMAST Free Lift Chain

1. With the lift truck wheels securely blocked, raise the forks approximately three feet from floor and position blocks or strong supports under the lift carriage.
2. Lower the lift carriage onto the support. Check that arrangement is secure before proceeding.
3. Turn off the key switch and disconnect the batteries.

WARNING: Before attempting any replacement, make certain power is disconnected.

4. Remove cotter pin and clevis pin connecting chain to chain anchor at the lift carriage.

5. Remove cotter pin and clevis pin connecting chain to chain anchor at free lift cylinder.
6. Remove chain from sheave.
7. Position new chain on sheave.
8. Secure chain to chain anchor at free lift cylinder with clevis pin and cotter pin.
9. Connect the opposite end of chain to chain anchor at the lift carriage with clevis pin and cotter pin.
10. Adjust the chains according to paragraph 8-2.
11. Reconnect the batteries and turn on the keyswitch

8-4.3. TRIMAST Secondary Lift Chain

1. With the lift truck wheels securely blocked, raise the forks approximately five feet from floor and position blocks or strong supports under masts.
2. Lower the masts onto the support. Check that arrangement is secure before proceeding.
3. Turn off the key switch and disconnect the batteries.

WARNING: Before attempting any replacement, make certain power is disconnected.

4. Remove cotter pin and clevis pin connecting chain to chain anchor at inner mast.
5. Remove cotter pin and clevis pin and connecting chain to chain anchor at outer mast.
6. Remove chain from sheave.
7. Position new chain on sheave.
8. Secure chain to chain anchor at outer mast with clevis pin and cotter pin.
9. Connect the opposite end of chain to chain anchor at inner mast with clevis pin and cotter pin.
10. Adjust the chains according to paragraph 8-2.
11. Reconnect the batteries and turn on the keyswitch.

8-5. LIFT CYLINDERS.

NOTE: Removal and repair of lift cylinders are covered in [SECTION 9](#).

NOTES

SECTION 9 HYDRAULIC SYSTEM SERVICING

9-1. LINES AND FITTINGS

WARNING: When forks are raised, pressure exists in the hydraulic system lines and fittings. To ensure release of pressure, forks must be fully lowered and the batteries disconnected before performing any maintenance on the hydraulic system.

NOTE: Leaking hydraulic fittings may be remedied by simply tightening fittings. If this does not remedy the leak, the fittings or line must be replaced.

1. Lower forks fully.
2. Turn off the key switch and disconnect the batteries.
3. Remove the compartment covers as described in paragraph 5-3.

CAUTION: Hydraulic oil can damage parts. Wipe off any oil immediately. Provide a container under the line or fitting before disconnecting.

Telescopic Trucks: Refer to and parts pictures for Hydraulic System (Telescopic) trucks and remove leaking line or fitting and replace it with a new line or fitting.

Trimast Trucks: Hydraulic System (TRIMAST) trucks and remove leaking line or fitting and replace it with a new line or fitting.

4. Check level of hydraulic oil. If required, add hydraulic oil to bring to proper level. Use hydraulic oil listed in [Table 3-2](#).
5. Reconnect the batteries and turn on the keyswitch (14, [Figure 12-42](#) or 14, [Figure 12-43](#)).
6. Operate the lift and lower buttons to refill the cylinder and lines with hydraulic oil.
7. Check level of hydraulic oil. If required, add hydraulic oil to bring to proper level. Use hydraulic oil listed in [Table 3-2](#).

8. Install the compartment covers as described in paragraph 5-3.

9-2. HYDRAULIC PUMP, MOTOR, AND RESERVOIR ASSY

The hydraulic pump/motor assembly can be disassembled and repaired. However, a defective pump, valve or motor requires replacement of that component.

WARNING: When forks are raised, pressure exists in the hydraulic system lines and fittings. To ensure release of pressure, forks must be fully lowered and the batteries disconnected before performing any maintenance on the hydraulic system.

9-2.1. Removal

1. Lower forks fully.
2. Turn off the key switch and disconnect the batteries.
3. Remove the compartment covers as described in paragraph 5-3.
4. Tag and disconnect electrical leads from motor and solenoid of pump/motor assembly

NOTE: The reservoir and hose will be filled with hydraulic oil. Place a container under the pump assembly to catch any hydraulic oil.

5. Disconnect hose from pump/motor assembly.
6. While supporting pump/motor assembly remove four screws and four lock washers.
7. Remove the pump/motor assembly (1).

9-2.2. Disassembly and Reassembly

1. Remove the hydraulic pump/motor assembly as described in paragraph 9-2.1.
2. Reassemble in reverse order.

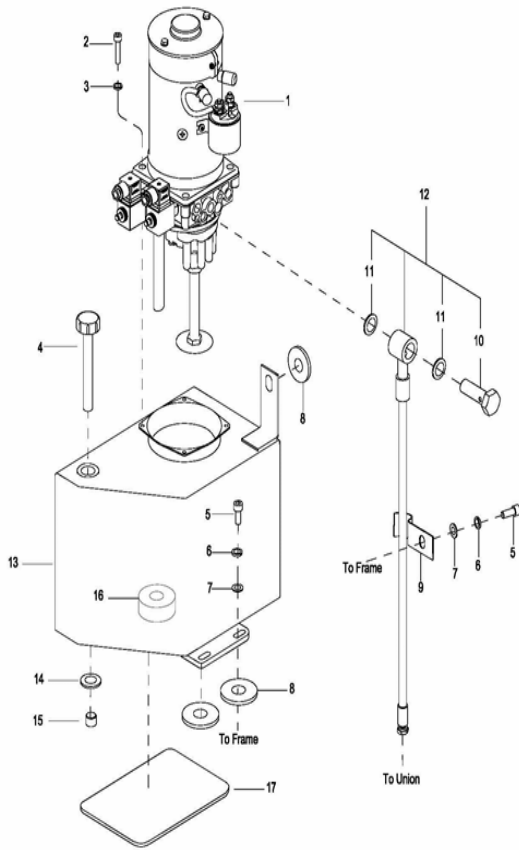

R6819 Hydraulic System (Used when not Side Shift)

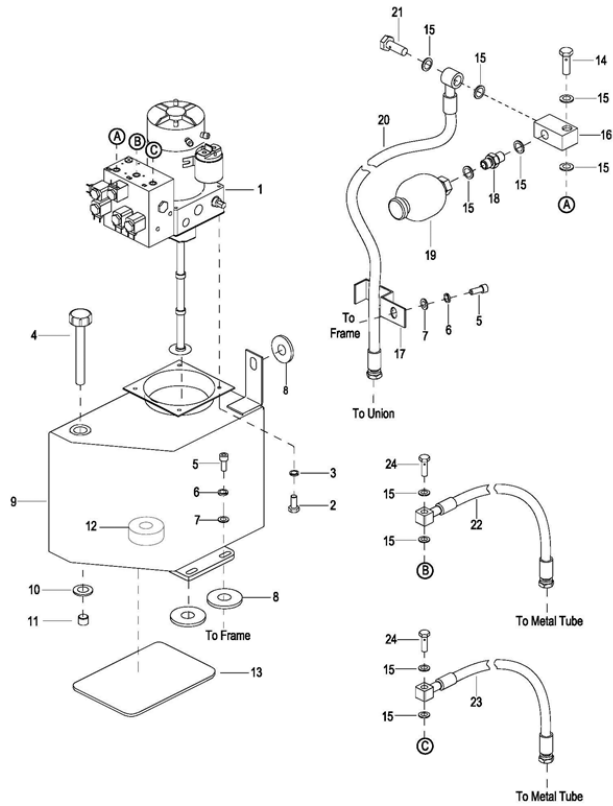

R8058 Hydraulic System (Used when Side Shift)

Figure 9-1 Hydraulic System

9-2.3. Installation

1. While supporting the pump/motor assembly, install four screws and four lock washers.
2. Reconnect hose to the pump/motor assembly.
3. Connect electrical leads to motor and solenoid of pump/motor assembly.
4. Fill the hydraulic reservoir. Use hydraulic oil listed in [Table 3-2](#).
5. Reconnect the batteries and turn on the key-switch.
6. Operate the lift and lower buttons to refill the cylinder and lines with hydraulic oil.
7. Check level of hydraulic oil. If required, add hydraulic oil to bring to proper level. Use hydraulic oil listed in [Table 3-2](#).
8. Install the compartment covers as described in paragraph [5-3](#).

9-2.4. Lift Cylinder (Telescopic)

9-2.4.1. Removal

1. With the lift truck wheels securely blocked, raise the forks approximately three feet from floor and position blocks or strong supports under inner mast
2. Lower inner mast onto the support. Check that arrangement is secure before proceeding.
3. Turn off the key switch and disconnect the batteries.

WARNING: Before attempting any replacement, make certain power is disconnected.

CAUTION: Hydraulic oil can damage parts. Wipe off any oil immediately. Provide a container under the line or fitting before disconnecting.

4. Disconnect the hose from the bottom of lift cylinder.
5. Manually push the cylinder rod down as far as possible.

WARNING: Support lift cylinder before performing the following steps to prevent cylinder from falling.

6. Remove two bolts, two lock washers, two flat washers, clip, bracket and shims.
7. Raise lift cylinder assembly up and out of truck.

9-2.4.2. Repair

CAUTION: To prevent damage, use proper pipe clamp vise. The cylinder will be distorted if the vise is tightened too much.

1. Secure the lift cylinder in a vise, clamping lightly at the base of the cylinder.
2. Remove gland nut.

3. Remove wiper ring and O-ring from gland nut.
4. Pull out piston rod.
5. Remove piston and O-ring from rod.
6. Remove guide ring and seal from piston.
7. Coat all parts with hydraulic oil ([Table 3-2](#)).
8. Install guide ring and new seal on piston.
9. Install new O-ring on rod.
10. Install piston on rod.
11. Insert rod in cylinder tube.
12. Install wiper ring and O-ring on gland nut.
13. Install gland nut in cylinder tube.

9-2.4.3. Installation

1. Position the cylinder on outer mast.
2. Install clip, bracket and shims and secure with two bolts, two lock washers, two flat washers.
3. Using a suitable lifting device, support the inner mast and remove the supports.
4. Slowly lower the inner mast while lining up the lift cylinder with its mounting taps.
5. Secure the top of the cylinder with screw, lock washer and flat washer.
6. Reconnect the hose to the bottom of lift cylinder.
7. Adjust the chains according to paragraph [8-2](#).
8. Fill the hydraulic reservoir. Use hydraulic oil listed in [Table 3-2](#).
9. Reconnect the batteries and turn on the key-switch.
10. Operate the lift and lower buttons to refill the cylinder and lines with hydraulic oil.
11. Check level of hydraulic oil. If required, add hydraulic oil to bring to proper level. Use hydraulic oil listed in [Table 3-2](#).
12. Install the compartment covers as described in paragraph [5-3](#).

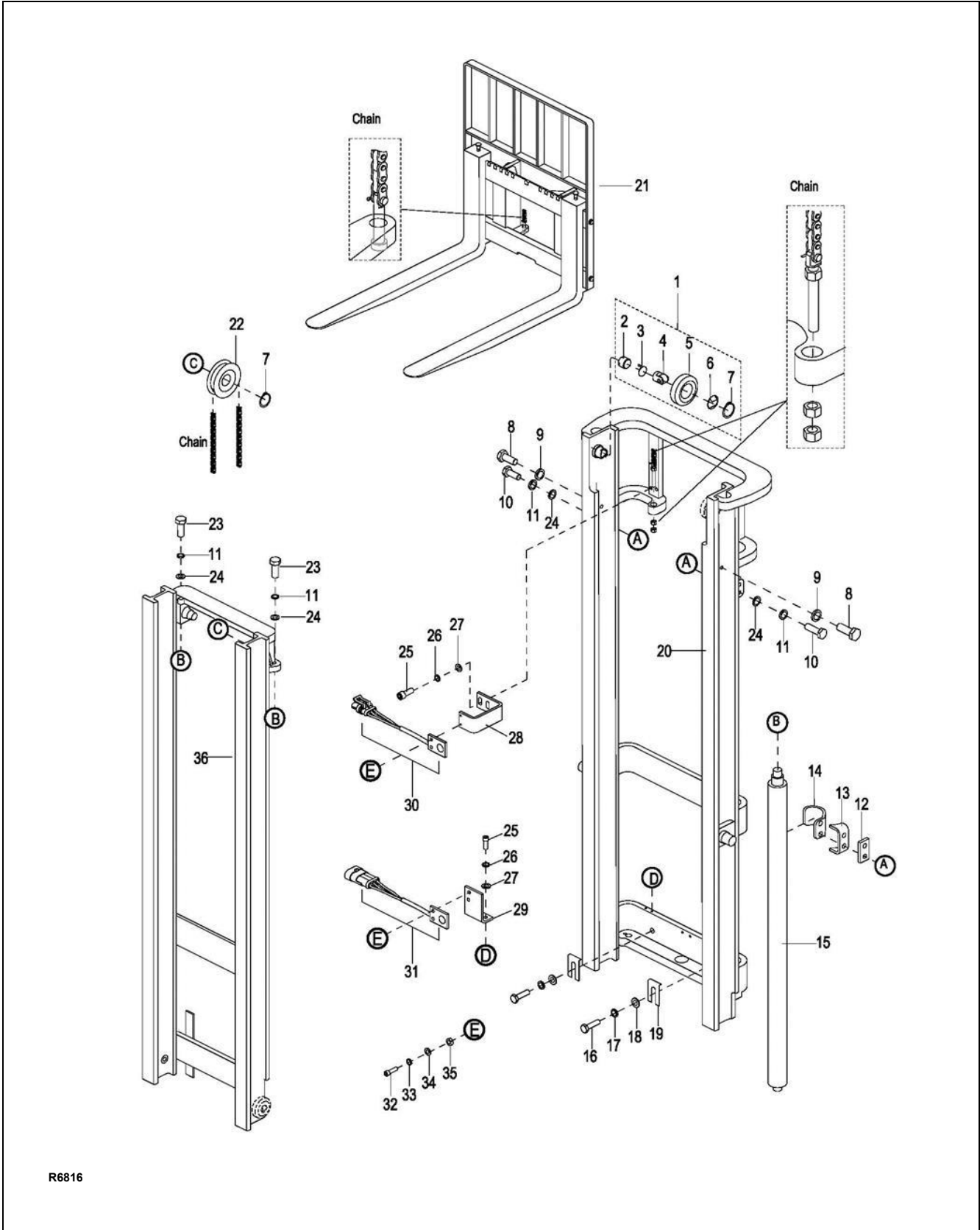

R6816

Figure 9-2 Mast (Telescopic)

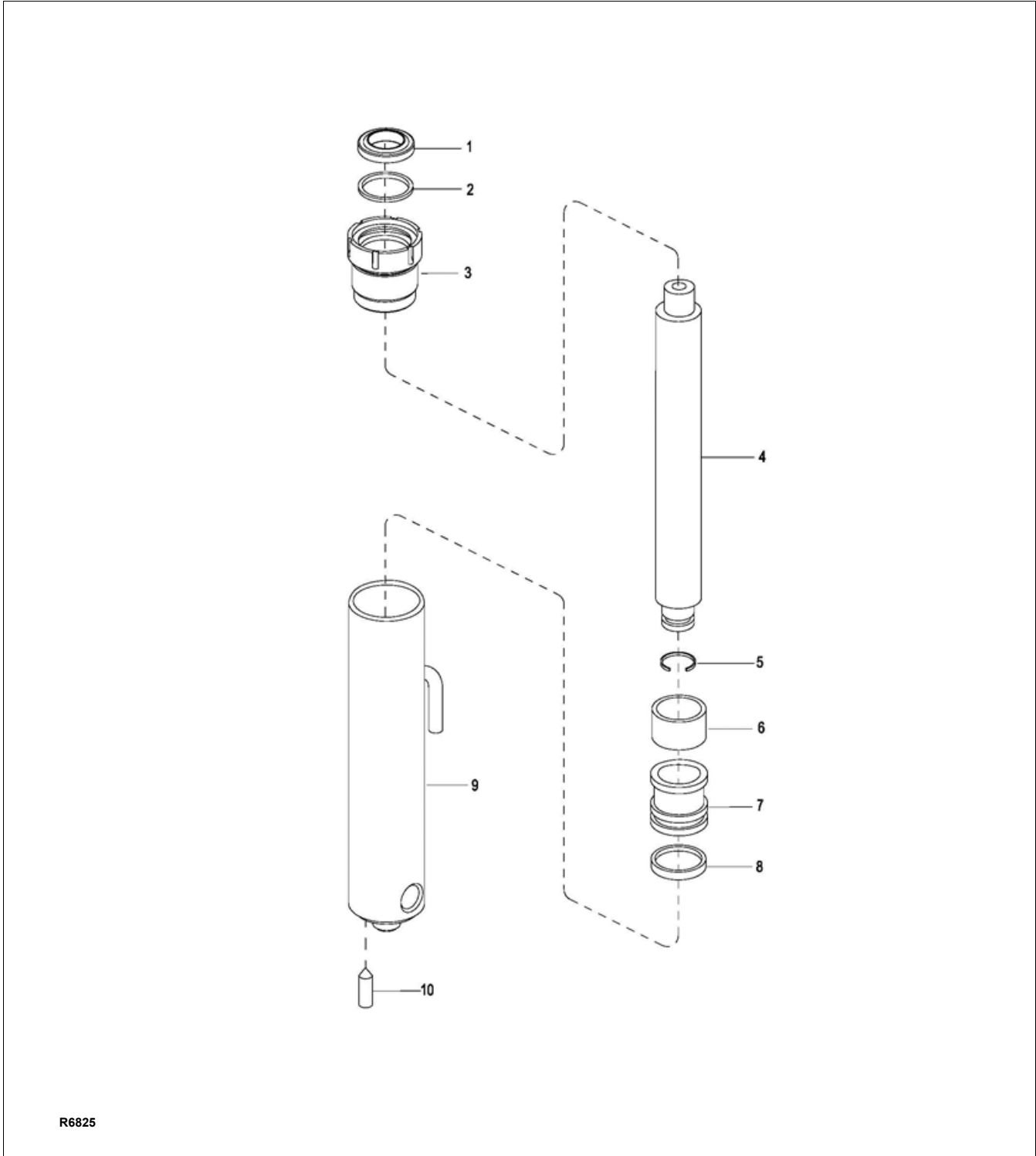

Figure 9-3 Lift Cylinder (Telescopic)

9-2.5. Lift Cylinder (TRIMAST Free Lift)

9-2.5.1. Removal

1. Fully lower the lift carriage.
2. Turn off the key switch and disconnect the batteries.

WARNING: Before attempting any repairs or replacements, make certain power is disconnected.

3. Using another lift truck or suitable jack, raise lift carriage far enough to remove pressure on the free lift cylinder
4. Remove cotter pin and clevis pin connecting the lift chain to the anchor at cylinder.
5. Remove chains from sheaves.
6. Remove screw, lock washer, flat washer, bracket and ram head from cylinder.

CAUTION: Hydraulic oil can damage parts. Wipe off any oil immediately. Provide a container under the line or fitting before disconnecting.

7. Disconnect the tube from the bottom of lift cylinder.
8. Support cylinder and remove two screws, two lock washers and two flat washers.
9. Raise lift cylinder assembly up and out of truck.

9-2.5.2. Repair

CAUTION: To prevent damage, use proper pipe clamp vise. The cylinder will be distorted if the vise is tightened too much.

1. Secure the lift cylinder in a vise, clamping lightly at the base of the cylinder.
2. Remove gland nut.

3. Remove wiper and O-ring from gland nut.
4. Pull out piston rod.
5. Remove guide ring, snap ring and inner collar from piston rod.
6. Coat all parts with hydraulic oil ([Table 3-2](#)).
7. Install guide ring, snap ring and inner collar on piston rod.
8. Insert rod in cylinder tube.
9. Install O-ring and wiper on gland nut.
10. Install gland nut in cylinder tube.

9-2.5.3. Installation

1. Position cylinder on inner mast and secure with two screws, two lock washers and two flat washers.
2. Reconnect the tube to the bottom of the cylinder.
3. Position bracket and ram head on cylinder and secure with screw, lock washer, and washer.
4. Position lift chains over sheave and secure lift chain to the anchor at cylinder with clevis pin and cotter pin.
5. Adjust the chains according to paragraph [8-2](#).
6. Fill the hydraulic reservoir. Use hydraulic oil listed in [Table 3-2](#).
7. Reconnect the batteries and turn on the key-switch.
8. Operate the lift and lower buttons to refill the cylinder and lines with hydraulic oil.
9. Check level of hydraulic oil. If required, add hydraulic oil to bring to proper level. Use hydraulic oil listed in [Table 3-2](#).
10. Install the compartment covers as described in paragraph [5-3](#).

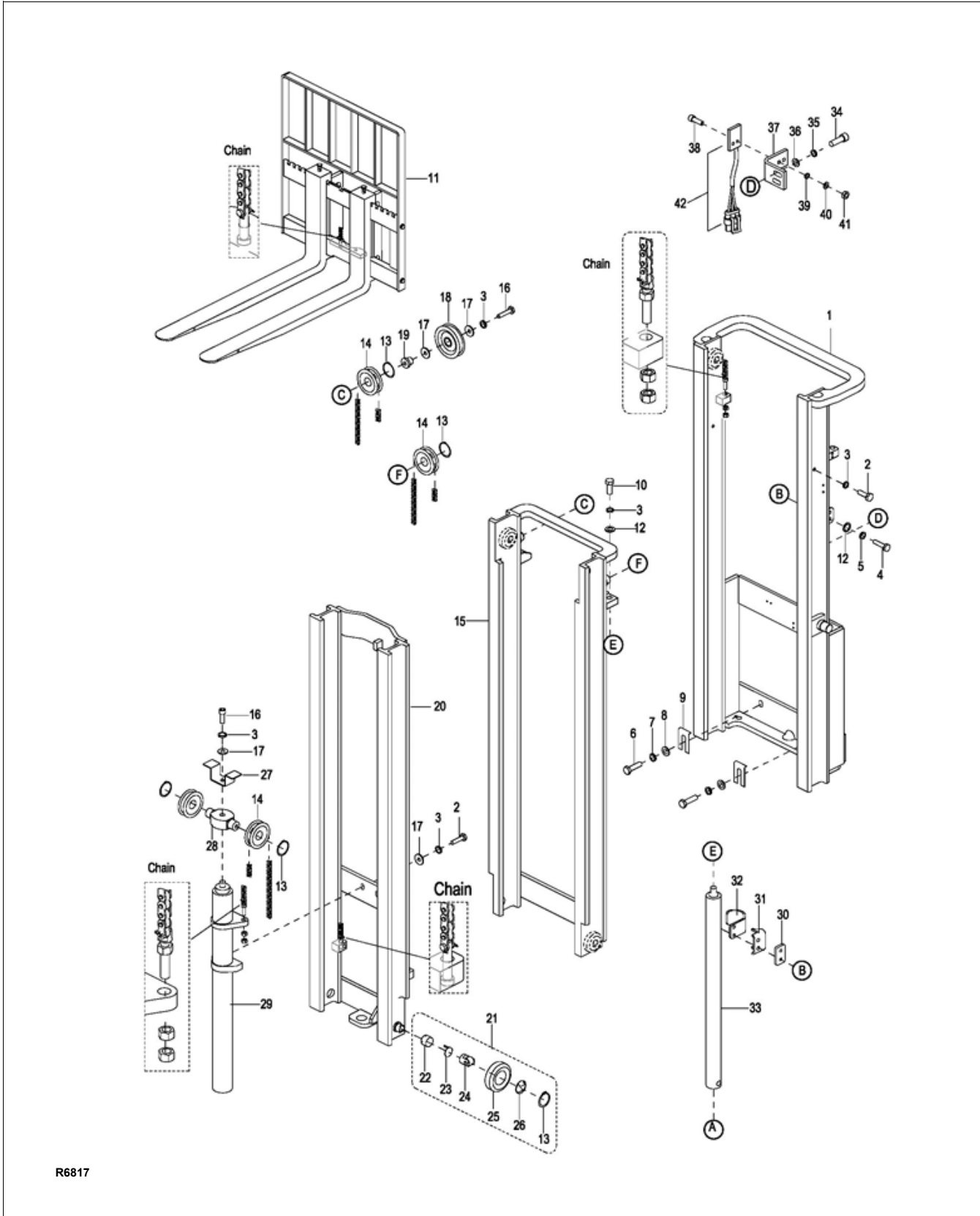

R6817

Figure 9-4 Mast (TRIMAST)

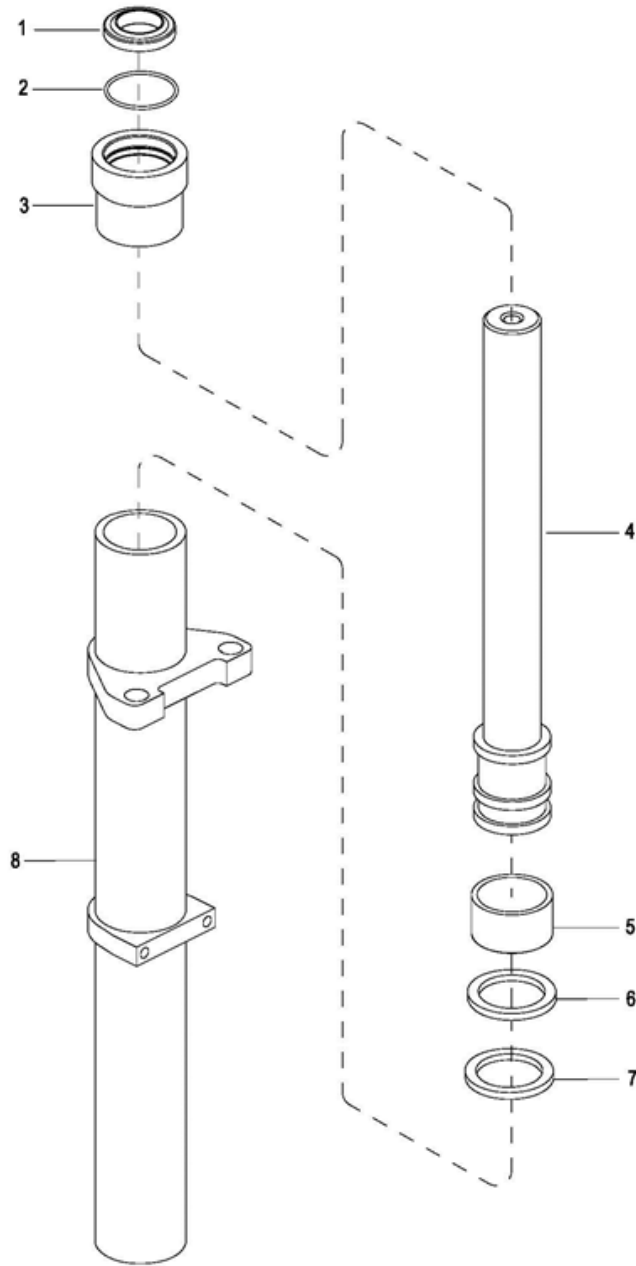

R6826

Figure 9-5 Free Lift Cylinder (TRIMAST)

9-2.6. Lift Cylinder (TRIMAST Secondary)

9-2.6.1. Removal

1. Fully lower the lift carriage.
2. Turn off the key switch and disconnect the batteries.

WARNING: Before attempting any replacement, make certain power is disconnected.

3. Remove bolt holding cylinder in place securing the top of cylinder to mast.
4. Using another lift truck or suitable jack, raise middle mast far enough to remove pressure on the secondary lift cylinder.

CAUTION: Hydraulic oil can damage parts. Wipe off any oil immediately. Provide a container under the line or fitting before disconnecting.

5. Disconnect the tube from the bottom of lift cylinder.
6. Support cylinder and remove two bolts, two lock washers, two flat washers, shims, bracket and clip.
7. Raise lift cylinder assembly up and out of truck.

9-2.6.2. Repair

CAUTION: To prevent damage, use proper pipe clamp vise. The cylinder will be distorted if the vise is tightened too much.

1. Secure the lift cylinder in a vise, clamping lightly at the base of the cylinder.
2. Remove gland nut.
3. Remove wiper and O-ring from gland nut.

4. Pull out piston rod.
5. Remove piston and O-ring from piston rod.
6. Remove ring and seal from piston.
7. Coat all parts with hydraulic oil ([Table 3-2](#)).
8. Install ring and seal on piston.
9. Install piston and O-ring on piston rod.
10. Insert rod in cylinder tube.
11. Install wiper and O-ring on gland nut).
12. Install gland nut in cylinder tube.

9-2.6.3. Installation

1. Using another lift truck or suitable jack, raise middle mast far enough to allow installation of the secondary lift cylinder.
2. Slowly lower mast while aligning cylinder with the top on mast.
3. Secure the top of cylinder with flat washer, lock washer and screw.
4. Install clip, bracket, shims, two flat washers, two lock washers, and two bolts.
5. Reconnect the tube to the bottom of the lift cylinder.
6. Fill the hydraulic reservoir. Use hydraulic oil listed in [Table 3-2](#).
7. Reconnect the batteries and turn on the key-switch.
8. Operate the lift and lower buttons to refill the cylinders and lines with hydraulic oil.
9. Check level of hydraulic oil. If required, add hydraulic oil to bring to proper level. Use hydraulic oil listed in [Table 3-2](#).
10. Install the compartment covers as described in paragraph [5-3](#).

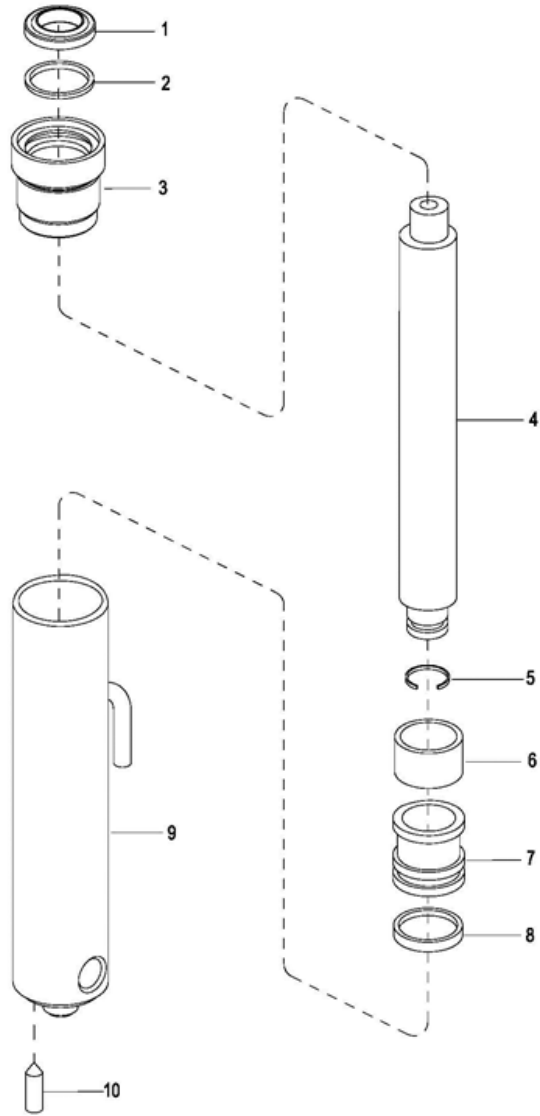

R6827

Figure 9-6 Secondary Lift Cylinder (TRIMAST)

SECTION 10 ELECTRICAL COMPONENTS

10-1.ELECTRICAL CONTROL PANEL

10-1.1.Maintenance

NOTE: Erratic operation of the truck may be caused by defective controller components. Before removing the electrical panel, perform troubleshooting procedures per [SECTION 4](#), to determine corrective action to be taken.

There are no user-serviceable parts inside the controller. No attempt should be made to open the controller. Opening the controller may damage it and will void the warranty.

The controller is programmed at the factory specifically for the truck model on which it is equipped. It is important to replace the controller with the correct pre-programmed unit to assure proper performance settings intended for that particular truck. See [Figure 12-44](#) for the preprogrammed controller number.

It is recommended that the controller exterior be cleaned periodically, and if a Zapi Handset is available, this periodic cleaning provides a good opportunity to check the controller's diagnostic history file. It is also recommended that the controller's fault detection circuitry be checked whenever the vehicle is serviced.

10-1.2. Cleaning

1. Turn off the key switch and disconnect the batteries.
2. Remove the compartment covers as described in paragraph [5-3](#).
3. Remove any dirt or corrosion from the bus bar area. The controller should be wiped clean with a

moist rag. Allow it to dry before reconnecting the battery.

4. Make sure the connections to the buss bars are tight. Use two well insulated wrenches for this task in order to avoid steering the buss bars.

10-1.3.Panel Removal.

1. Turn off the key switch and disconnect the batteries.
2. Remove the compartment covers as described in paragraph [5-3](#).
3. Tag and disconnect all electrical cables which connect to the control panel.
4. Remove two screws, two washers, two flat washers and control panel.

10-1.4.Panel Disassembly.

Refer to the parts page for location and identity of the major replacement components mounted on the panel and remove defective parts.

NOTE: Contactor is not repairable and must be replaced if defective.

10-1.5.Panel Installation.

1. Install the control panel and secure with two screws, two washers, two flat washers.
2. Refer to and, connect all electrical cables to the control panel as noted during removal.
3. Install the compartment covers as described in paragraph [5-3](#).
4. Reconnect the batteries and turn on the key-switch.

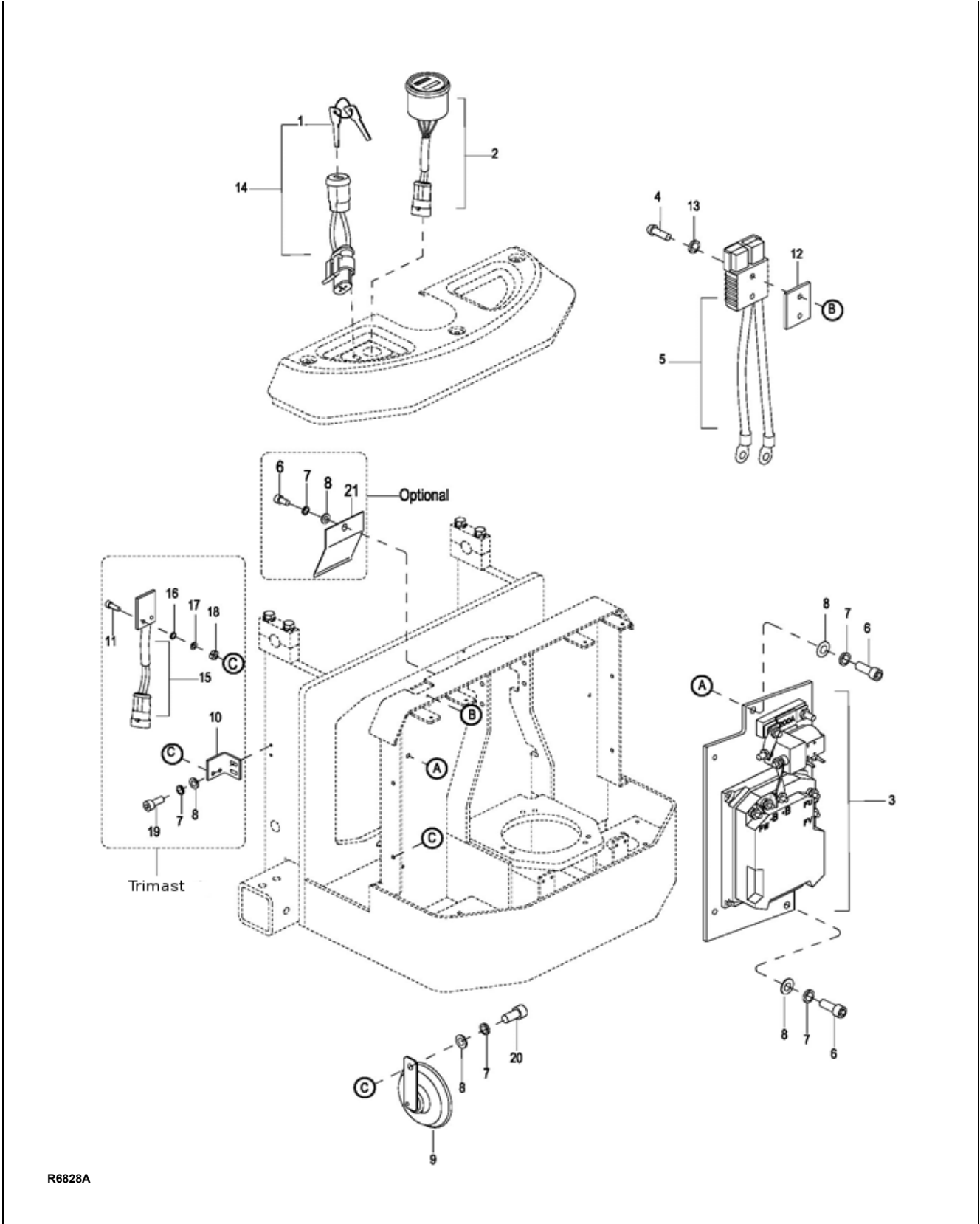

R6828A

Figure 10-1 Electrical System

10-2.HORN REPLACEMENT

1. Turn off the key switch and disconnect the batteries.
2. Remove the compartment covers as described in paragraph 5-3.
3. Tag and disconnect all electrical connections from horn.
4. Remove screw, lock washer, flat washer, and horn.
5. Install horn and secure with screw, lock washer, flat washer.
6. Install the compartment covers as described in paragraph 5-3.
7. Reconnect the batteries and turn on the key switch.

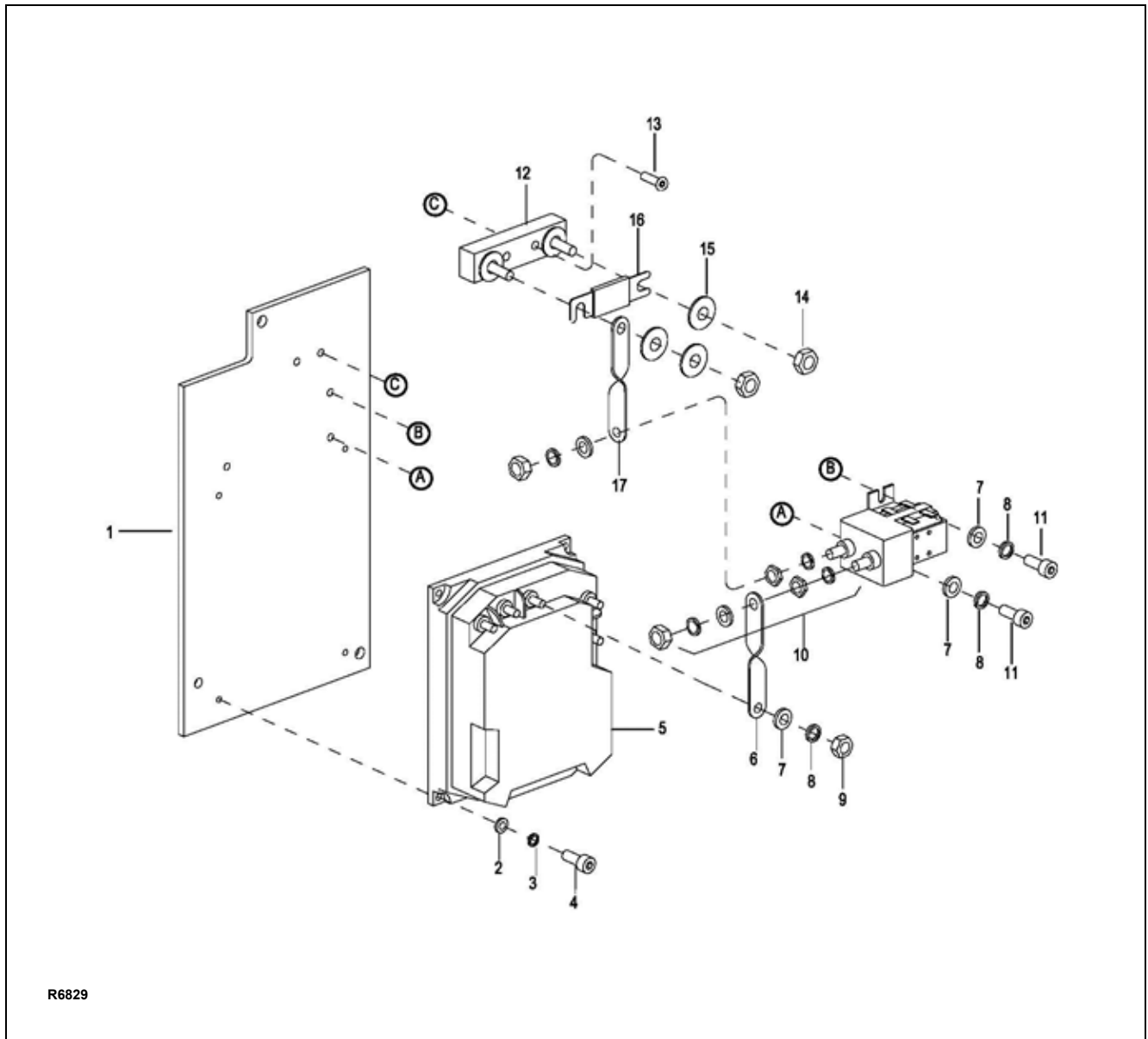

Figure 10-2 Electrical Panel

10-3.PUMP MOTOR.

The pump motor is replaceable but not repairable. Refer to paragraph 9-2.

10-4.DRIVE MOTOR.

The drive motor exposed surfaces should be cleaned at least once a month to assure proper cooling of motor. Use an air hose to blow dust off of motor surfaces.

10-4.1.Motor Removal

1. Remove the brake as described in paragraph 6-1.3.
2. Remove the transmission as described in paragraph 7-2.
3. Remove the eight screws, eight lock washers and eight flat washers..
4. Lift motor from transmission.
5. Remove three screws, three lock washer and plate from the motor.
6. Remove mounting nut and gear from the motor.

10-4.2.Motor Installation

1. Position key gear on the shaft of motor and secure with the mounting nut.
2. Install plate on the motor and secure with three screws and three lock washer.
3. Install drive motor onto transmission. Make sure to align the gears.
4. Reinstall the eight screws, eight lock washers and eight flat washers to secure the motor to the transmission.
5. Install the transmission as described in paragraph 7-2.
6. Reinstall the brake as described in paragraph 6-1.3.

10-5.DEADMAN SWITCH

10-5.1.Replacement

1. Disconnect harness from the dead man switch.
2. Remove the two screws, two lock washers and switches from bracket.
3. Position the new switches on bracket and secure with the two screws and lock washers.
4. Reconnect harness to the dead man switch.

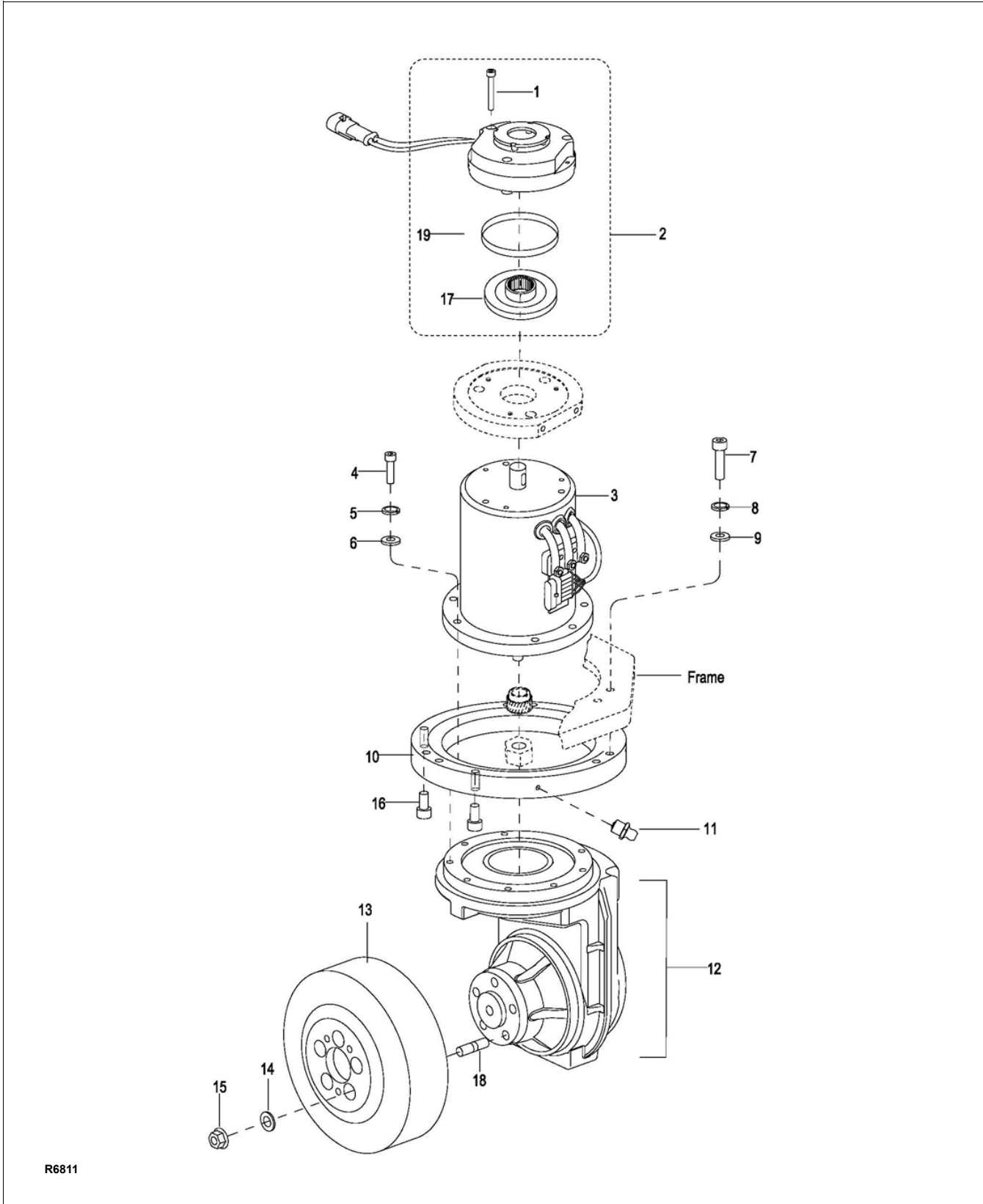

Figure 10-3 Transmission, Motor, Brake Assembly

NOTES

SECTION 11 OPTIONAL EQUIPMENT

11-1.LOAD BACKREST

A load backrest is available for addition to the lift truck to allow handling of high loads.

NOTES

SECTION 12
ILLUSTRATED PARTS BREAKDOWN

Following is an illustrated parts breakdown of assemblies and parts associated with the PDS Lift Truck.

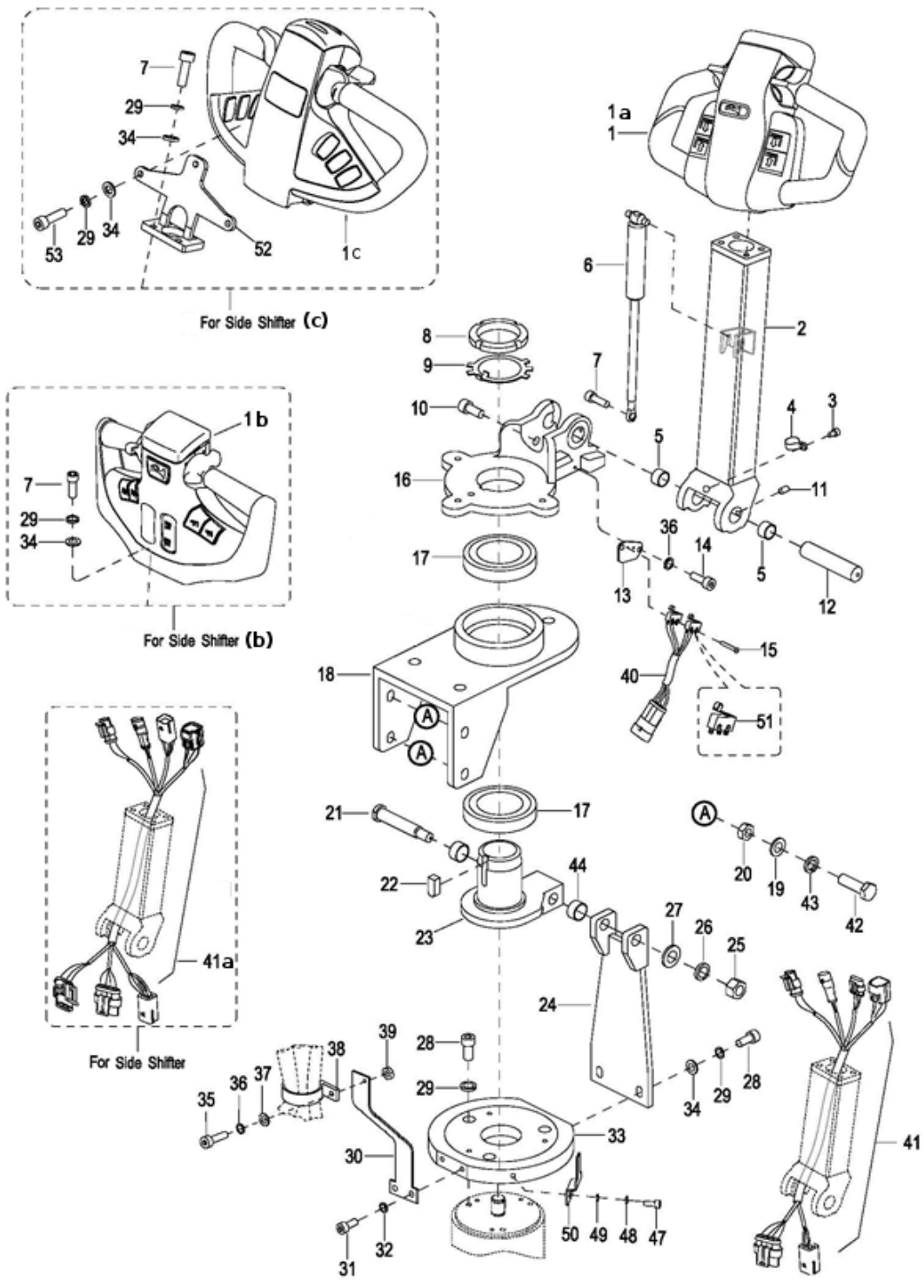

R6807

Figure 12-1 Steering System - Used up to serial number 3281901818

STEERING SYSTEM - Used up to serial number 3281901818

Pos.	Part Number	Description	Qty. Reqd.	Notes
1	2125-340000-00-B	CONTROL POD ASSEMBLY	1	Used up to serial number 327120792
1a	2125-340000-00-C	CONTROL POD ASSEMBLY	1	Used between serial number 327120793 - 3281901818
1b	1280-360000-10-B	CONTROL POD ASSEMBLY	1	Used when side shift option, up to serial number S2315284
1c	2130-350000-40	CONTROL POD ASSEMBLY	1	Used when side shift option, between serial number S2315285 - 3281901818
2	2130-340000-00	CONTROL HANDLE	1	
2a	2130-340000-40	CONTROL HANDLE	1	Used when side shift option, up to serial number S2315284
2b	2130-360000-40	CONTROL HANDLE	1	Used when side shift option, between serial number S2315285 - 3281901818
3	0000-000010-00	SCREW M5×6	1	
4	0000-000490-00	HARNESS CLAMP	1	
5	0000-000011-00	BEARING 2015	2	
6	2130-350000-00	GAS SPRING	1	
7	0000-000322-00	SCREW M8×25	1	
8	0000-000114-00	NUT M52×1.5	1	
9	0000-000143-00	CHECK WASHER Ø52×1.5	1	
10	0000-000030-00	SCREW M10×16	1	
11	0000-000429-00	SCREW M5×8	1	
12	1120-300003-00	SHAFT	1	
13	2130-300006-00	SPACER	1	
14	0000-000088-00	SCREW M4×8	2	
15	0000-000377-00	SCREW M2×20	2	
16	2130-300001-00	TURNING BRACKET	1	
17	0000-000142-00	BEARING	2	
18	2130-330000-00	BRACKET	1	
19	0000-000007-00	FLATWASHER Ø10	4	
20	0000-000553-00	NUT M10	4	
21	1420-300001-00	PIN	1	
22	0000-000735-00	B TYPE KEY 8×7×14	1	
23	2130-320000-00	BRACKET	1	
24	2130-310000-00	BRACKET	1	

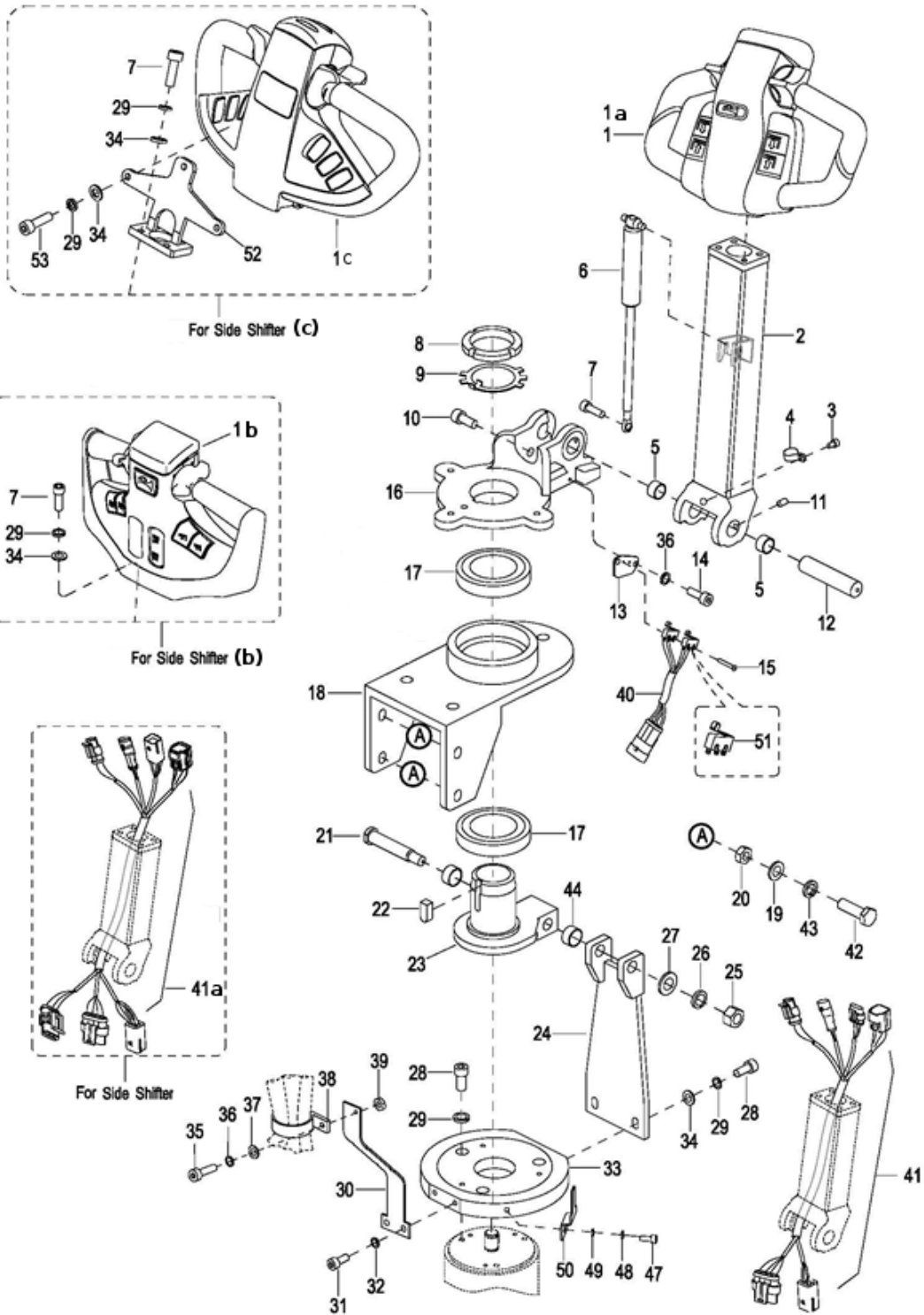

R6807

Figure 12-1 Steering System - Used up to serial number 3281901818 - Continued

STEERING SYSTEM - USED UP TO SERIAL NUMBER 3281901818 - CONTINUED

Pos.	Part Number	Description	Qty. Reqd.	Notes
25	0000-000165-00	NUT M12	1	
26	0000-000060-00	LOCKWASHER Ø12	1	
27	0000-000222-00	FLATWASHER Ø12	1	
28	0000-000109-00	SCREW M8×16	5	
29	0000-000159-00	LOCKWASHER Ø8	8	
30	1220-300007-00	FIXED PLATE	1	
31	0000-000055-00	SCREW M6×16	2	
32	0000-000056-00	LOCKWASHER Ø6	2	
33	1420-300006-00	BRAKE BASE	1	
34	0000-000176-00	FLATWASHER Ø8	5	
35	0000-000378-00	SCREW M4×16	1	
36	0000-000122-00	LOCKWASHER Ø4	3	
37	0000-000702-00	FLATWASHER Ø4	1	
38	0000-000491-00	PLASTIC RING	1	
39	0000-000209-00	NUT M4	1	
40	2130-520004-00	WIRE HARNESS -BELLY SWITCH	1	
41	2130-520002-00	WIRE HARNESS	1	
41a	2320-520002-00	WIRE HARNESS	1	Used when truck has Side Shift option
42	0000-000283-00	BOLT M10×35	4	
43	0000-000063-00	LOCKWASHER Ø10	4	
44	0000-000011-00	BUSHING	2	
47	0000-000117-00	SCREW M5×10	1	
48	0000-000206-00	LOCKWASHER Ø5	1	
49	0000-000390-00	FLATWASHER Ø5	1	
50	1120-300007-00	BRACKET	1	
51	1220-560001-00	INCHING SWITCH I	2	
52	2333-320000-10	CONTROL POD BRACKET	1	Used between serial number S2315285 - 3281901818
53	0000-000321-00	SCREW M8×20	3	Used between serial number S2315285 - 3281901818

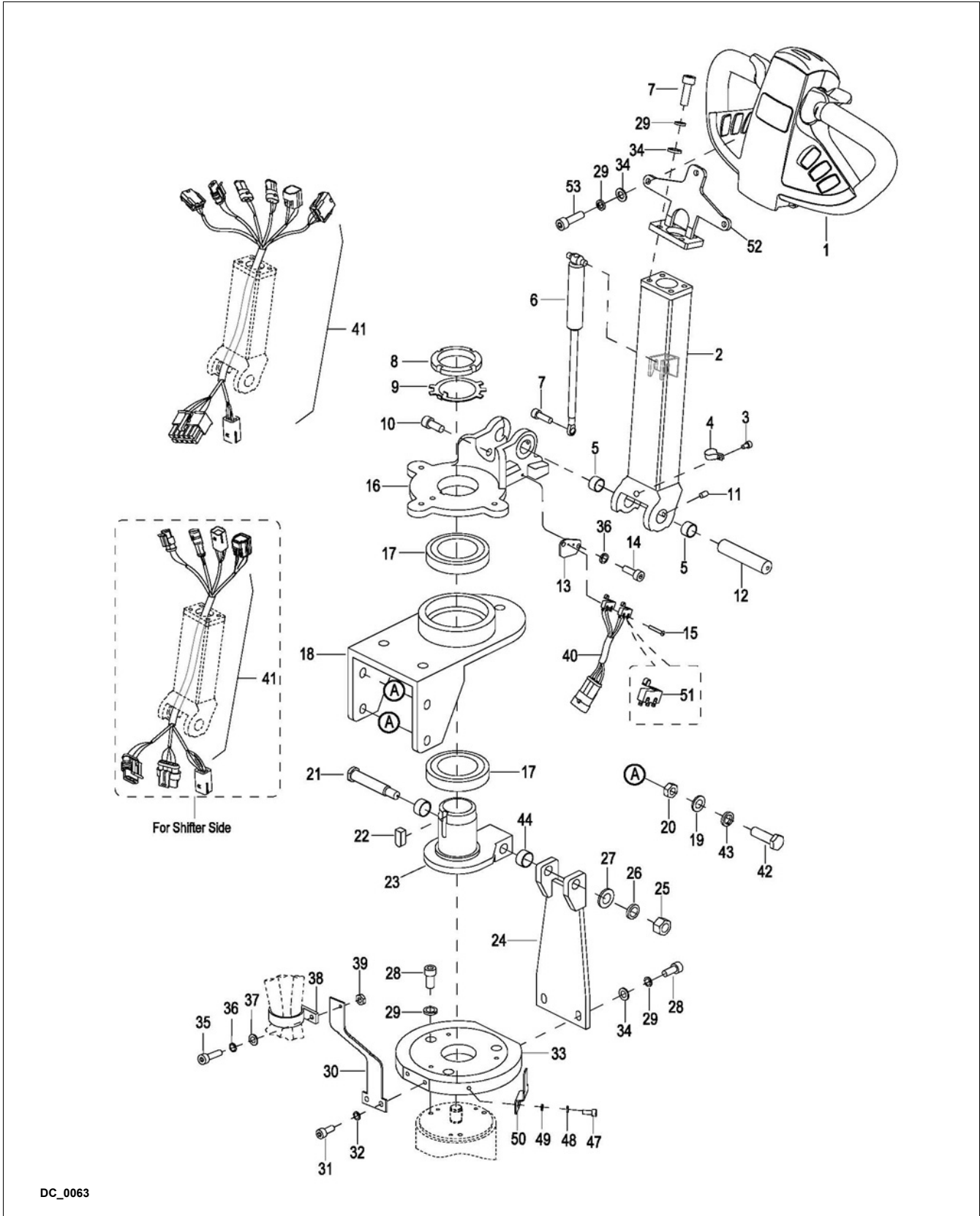

DC_0063

Figure 12-2 Steering System - Used from serial number 3281901819

STEERING SYSTEM - Used from serial number 3281901819

Pos.	Part Number	Description	Qty. Reqd.	Notes
1	2333-340000-03	CONTROL POD ASSEMBLY	1	With proportional valve
1b	2130-350000-40	CONTROL POD ASSEMBLY	1	Used when side shift option, from serial number S2315285
2	2130-340000-00	CONTROL HANDLE	1	
2a	2130-340000-40	CONTROL HANDLE	1	Used when side shift option, up to serial number S2315284
2b	2130-360000-40	CONTROL HANDLE	1	Used when side shift option, from serial number S2315285
3	0000-000010-00	SCREW M5×6	1	
4	0000-000490-00	HARNESS CLAMP	1	
5	0000-000011-00	BEARING 2015	2	
6	2130-350000-00	GAS SPRING	1	
7	0000-000322-00	SCREW M8×25	5	
8	0000-000114-00	NUT M52×1.5	1	
9	0000-000143-00	CHECK WASHER Ø52×1.5	1	
10	0000-000030-00	SCREW M10×16	1	
11	0000-000429-00	SCREW M5×8	1	
12	1120-300003-00	SHAFT	1	
13	2130-300006-00	SPACER	1	
14	0000-000088-00	SCREW M4×8	2	
15	0000-000377-00	SCREW M2×20	2	
16	2130-300001-00	TURNING BRACKET	1	
17	0000-000142-00	BEARING	2	
18	2130-330000-00	BRACKET	1	
19	0000-000007-00	FLATWASHER Ø10	4	
20	0000-000553-00	NUT M10	4	
21	1420-300001-00	PIN	1	
22	0000-000735-00	B TYPE KEY 8×7×14	1	
23	2130-320000-00	BRACKET	1	
24	2130-310000-00	BRACKET	1	

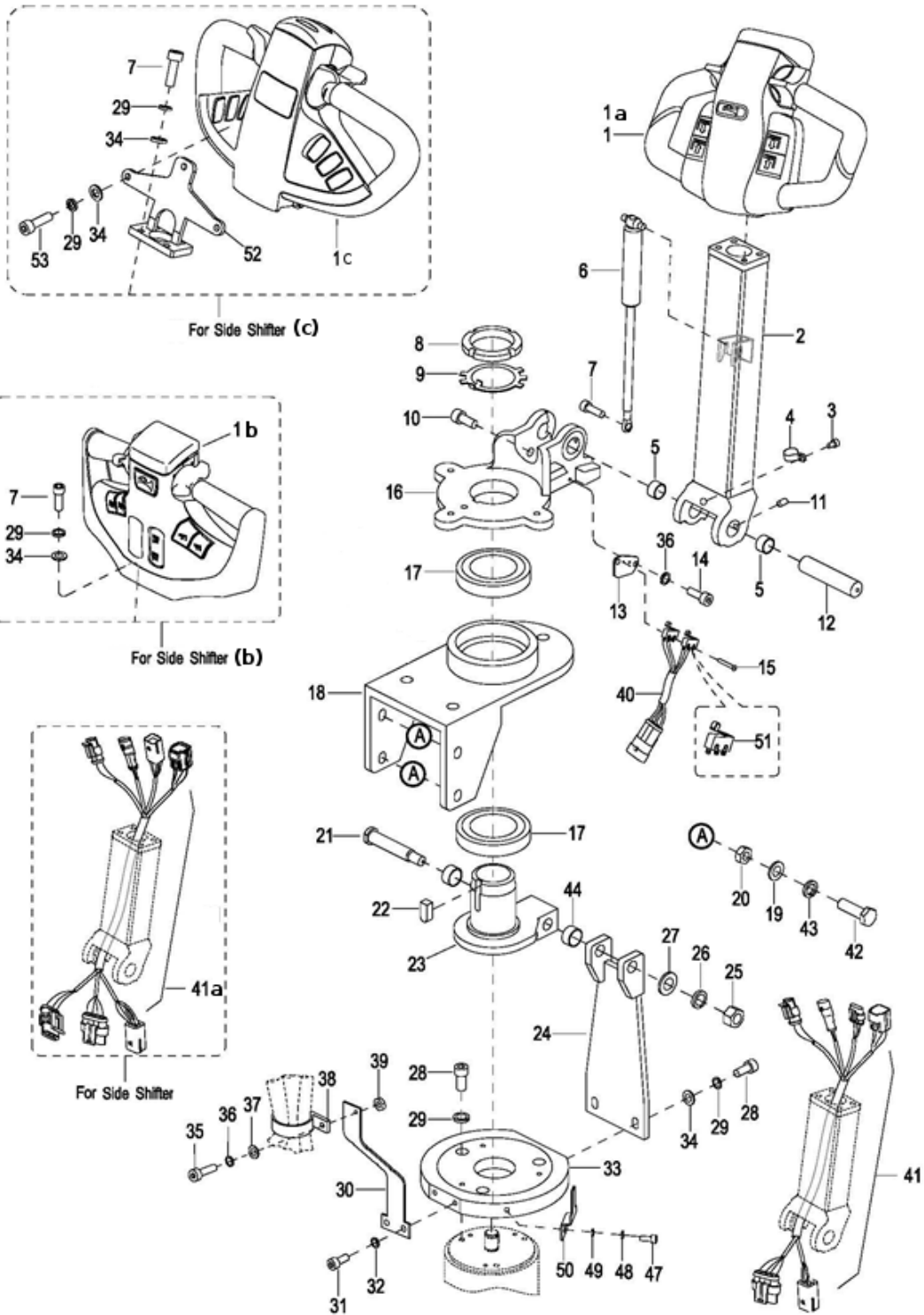

R6807

Figure 12-2 Steering System - Used from serial number 3281901819 - Continued

STEERING SYSTEM - USED FROM SERIAL NUMBER 3281901819 - CONTINUED

Pos.	Part Number	Description	Qty. Reqd.	Notes
25	0000-000165-00	NUT M12	1	
26	0000-000060-00	LOCKWASHER Ø12	1	
27	0000-000222-00	FLATWASHER Ø12	1	
28	0000-000109-00	SCREW M8×16	5	
29	0000-000159-00	LOCKWASHER Ø8	8	
30	1220-300007-00	FIXED PLATE	1	
31	0000-000055-00	SCREW M6×16	2	
32	0000-000056-00	LOCKWASHER Ø6	2	
33	1420-300006-00	BRAKE BASE	1	
34	0000-000176-00	FLATWASHER Ø8	5	
35	0000-000378-00	SCREW M4×16	1	
36	0000-000122-00	LOCKWASHER Ø4	3	
37	0000-000702-00	FLATWASHER Ø4	1	
38	0000-000491-00	PLASTIC RING	1	
39	0000-000209-00	NUT M4	1	
40	2130-520004-00	WIRE HARNESS -BELLY SWITCH	1	
41	2140-520002-AC	WIRE HARNESS	1	
41a	2320-520002-00	WIRE HARNESS	1	Used when truck has Side Shift option
42	0000-000283-00	BOLT M10×35	4	
43	0000-000063-00	LOCKWASHER Ø10	4	
44	0000-000011-00	BUSHING	2	
47	0000-000117-00	SCREW M5×10	1	
48	0000-000206-00	LOCKWASHER Ø5	1	
49	0000-000390-00	FLATWASHER Ø5	1	
50	1120-300007-00	BRACKET	1	
51	1220-560001-00	INCHING SWITCH I	2	
52	2333-320000-10	CONTROL POD BRACKET	1	

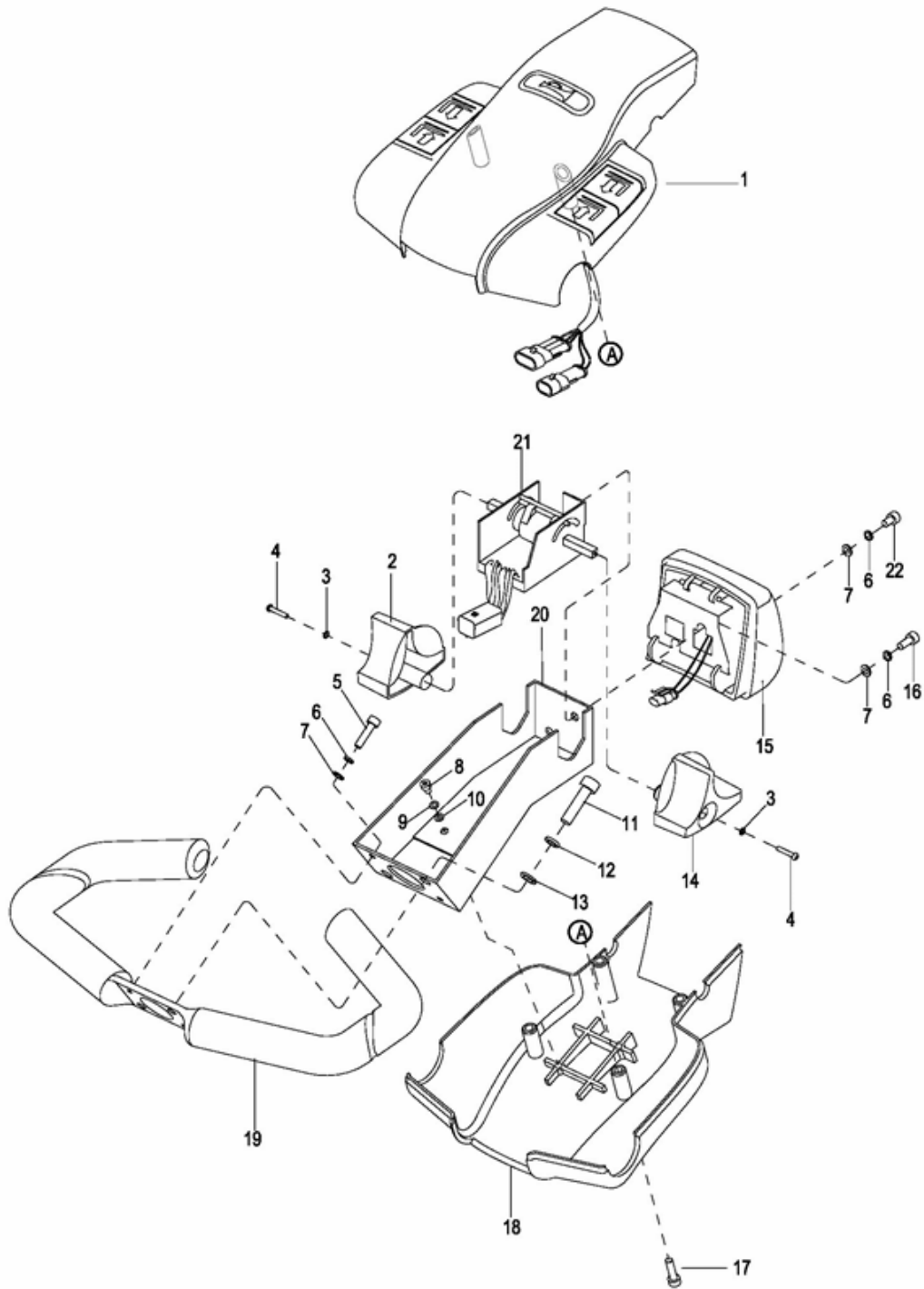

R6808

Figure 12-3 Control Handle Assembly - Used up to Serial Number 327120792 (Not used when Side Shift)

CONTROL HANDLE ASSEMBLY

USED UP TO SERIAL NUMBER 327120792 (NOT USED WHEN SIDE SHIFT)

Pos.	Part Number	Description	Qty. Reqd.	Notes
1	2125-342000-00-B	CAP ASSEMBLY	1	With Wire
2	1120-340005-00	CONTROL KNOB R	1	
3	0000-000038-00	LOCKWASHER Ø3	2	
4	0000-000037-00	SCREW M3×12	2	
5	0000-000004-00	SCREW M5×12	2	
6	0000-000206-00	LOCKWASHER Ø5	4	
7	0000-000390-00	FLATWASHER Ø5	4	
8	0000-000088-00	SCREW M4×8	2	
9	0000-000122-00	LOCKWASHER Ø4	2	
10	0000-000702-00	FLATWASHER Ø4	2	
11	0000-000322-00	SCREW M8×25	2	
12	0000-000159-00	LOCKWASHER Ø8	2	
13	0000-000176-00	FLATWASHER Ø8	2	
14	1120-340003-00	CONTROL KNOB L	1	
15	1120-343000-00-B	REVERSING SWITCH ASSEMBLY	1	With Wire
16	0000-000004-00	SCREW M5×12	1	
17	0000-000035-00	SCREW M5×20	4	
18	1120-340002-00	COVER	1	
19	1120-341000-00	HANDLE	1	
20	1120-340001-00	POD	1	
21	1220-520008-0C	ACCELERATOR HARNESS	1	
22	0000-000010-00	SCREW M5×6	1	

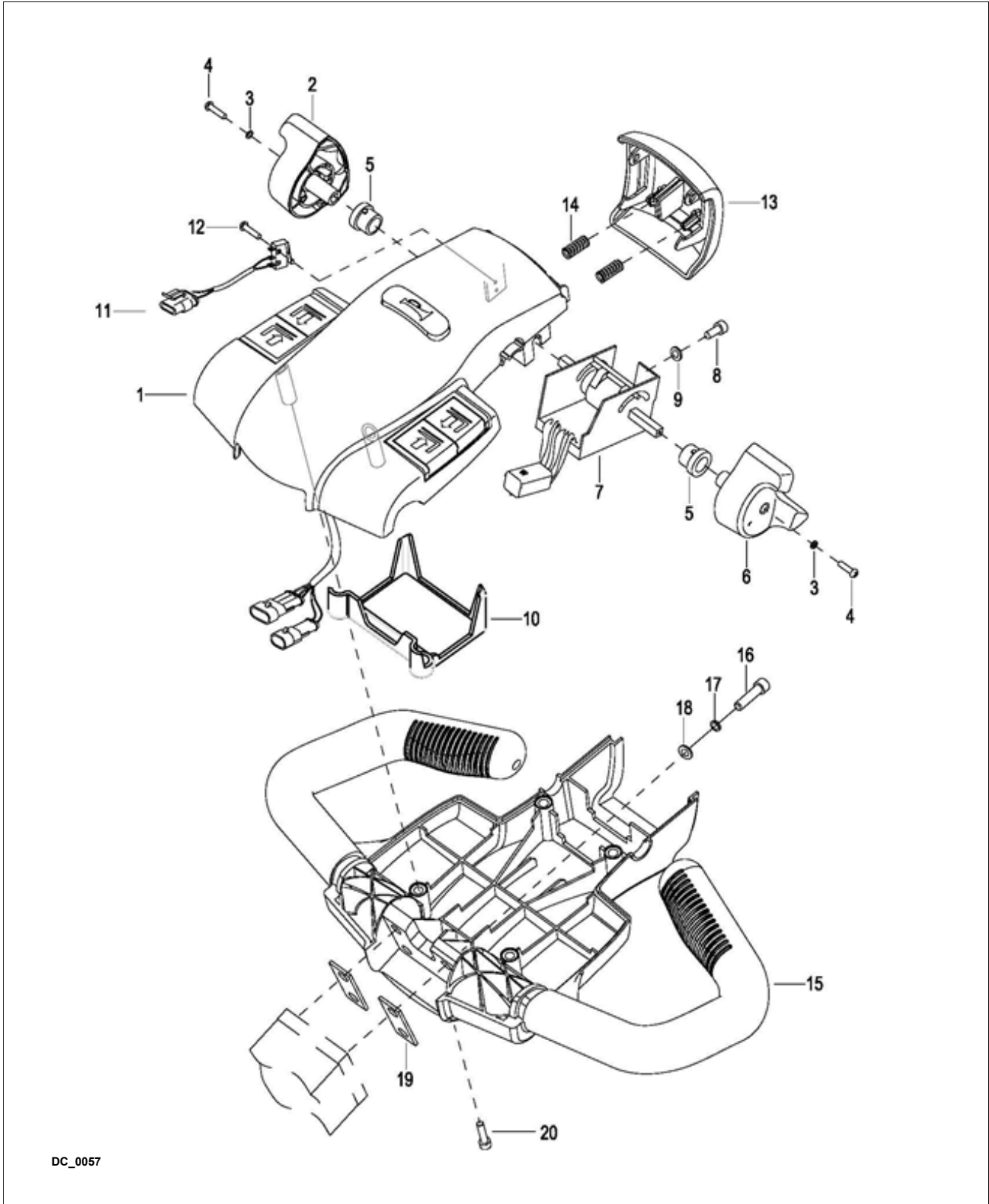

DC_0057

**Figure 12-4 Control Handle Assembly - Used between Serial Number 327120793 - 3281901818
(Not used when Side Shift)**

CONTROL HANDLE ASSEMBLY

USED BETWEEN SERIAL NUMBER 327120793 - 3281901818 (NOT USED WHEN SIDE SHIFT)

Pos.	Part Number	Description	Qty. Reqd.	Notes
1	2125-342000-00-C	CAP ASSEMBLY	1	
2	1115-340005-00	CONTROL KNOB RIGHT SIDE	1	
3	0000-000038-00	LOCK WASHER $\varnothing 3$	2	
4	0000-000037-00	SCREW M3 \times 12	2	
5	1115-340006-00	BUSHING	2	
6	1115-340004-00	CONTROL KNOB LEFT SIDE	1	
7	1120-340004-00-01	ACCELERATOR ASSEMBLY	1	
8	0000-000323-00	SCREW M5 \times 16	1	
9	0000-000390-00	FLAT WASHER $\varnothing 5$	1	
10	1115-340007-00	WIRE HARNESS COVER	1	
11	1120-520009-00	EMERGENCY REVERSE SWITCH	1	
12	0000-000989-00	SCREW M2 \times 12	2	
13	1115-340003-00	COVER	1	
14	1121-310004-00	SPRING	2	
15	1115-340002-00	COVER	1	
16	0000-000322-00	SCREW M8 \times 25	4	
17	0000-000159-00	LOCK WASHER $\varnothing 8$	4	
18	0000-000176-00	FLAT WASHER $\varnothing 5$	4	
19	1115-340001-00	WASHER	2	
20	0000-000035-00	SCREW M5 \times 20	4	

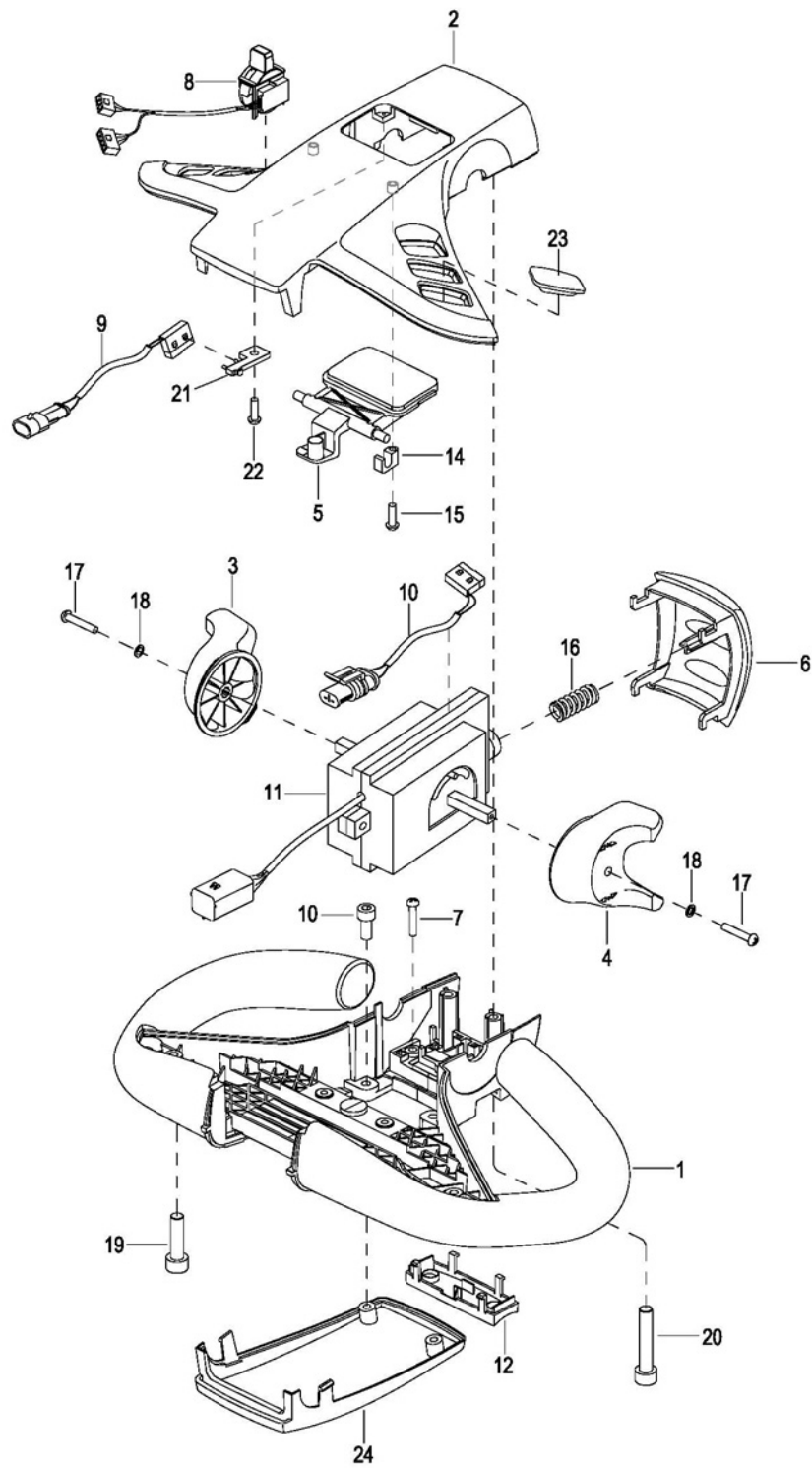

DC_0064

**Figure 12-5 Control Handle Assembly - Used from Serial Number 3281901819
(Not used when Side Shift)**

CONTROL HANDLE ASSEMBLY

USED FROM SERIAL NUMBER 3281901819 (NOT USED WHEN SIDE SHIFT)

Pos.	Part Number	Description	Qty. Reqd.	Notes
1	2333-340001-00	COVER	1	
2	2333-340002-00	CAP	1	
3	2333-340003-00	CONTROL KNOB RIGHT SIDE	1	
4	2333-340004-00	CONTROL KNOB LEFT SIDE	1	
5	2333-340005-00	HORN BUTTON	1	
6	2333-340006-00	EMERGENCY REVERSE COVER	1	
7	2333-340025-00	SCREW ST2.9×20	2	
8	2333-340008-00	PROPORTIONAL LIFT & LOWER SWITCH	1	
9	2333-520005-10	HORN WIRE HARNESS	1	
10	2333-520004-10	REVERSING SWITCH WIRE	1	
11	2333-520003-10	ACCELERATOR ASSEMBLY	1	
12	2333-340024-00	SCREW M5×12	2	
13	2333-340023-00	BUTTON	1	
14	2333-340009-00	MOUNTING SEAT	2	
15	2333-340012-00	SCREW ST2.9×9.5	2	
16	2333-340010-00	SPRING	1	
17	0000-000037-00	SCREW M3×12	2	
18	0000-000038-00	LOCK WASHER Ø3	2	
19	2333-340013-00	SCREW	2	
20	2333-340014-00	SCREW M5×50	2	
21	2333-340018-00	BRACKET	1	
22	2333-340019-00	SCREW M3×10	1	
23	2333-340020-00	COVER	5	
24	2333-340022-00	SEALING PLATE	1	

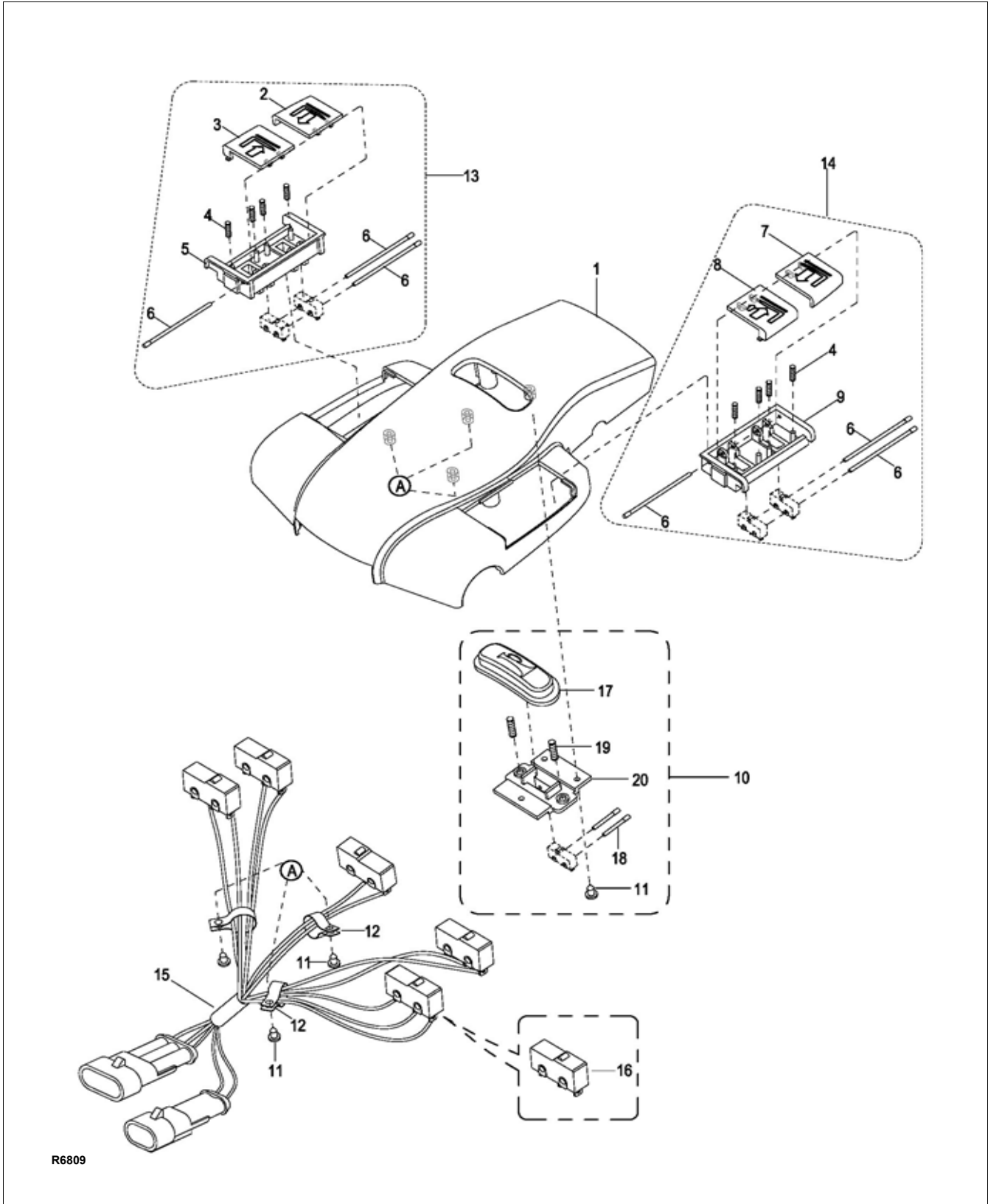

R6809

Figure 12-6 Upper Cover Assembly - Used up to serial number 3281901818
(Not used when Side Shift)

**UPPER COVER ASSEMBLY - USED UP TO SERIAL NUMBER 3281901818
(NOT USED WHEN SIDE SHIFT)**

Pos.	Part Number	Description	Qty. Reqd.	Notes
1	1120-342001-00	UPPER COVER	1	Used up to Serial Number 327120792
1a	1115-341001-00	UPPER COVER	1	Used between Serial Number 327120793 - 3281901818
2	1120-342203-00	BUTTON FOR LIFTING(R)	1	
3	1120-342202-00	BUTTON FOR LOWERING(R)	1	
4	1120-342102-00	SPRING	8	
5	1120-342201-00	BUTTON BRACKET(R)	1	
6	1120-342105-00	PIN	6	
7	1120-342104-00	BUTTON FOR LIFTING(L)	1	
8	1120-342103-10	2-SPEED BUTTON FOR LOWERING(L)	1	
9	1120-342101-00	BUTTON BRACKET (L)	1	
10	1120-342300-00	HORN BUTTON ASSEMBLY	1	
11	0000-000039-00	SCREW ST3.5×9.5	6	
12	0000-000490-00	LINE CLAMP	3	
13	1120-342200-00	LIFTING AND LOWER BOX(R) ASSEMBLY	1	
14	2125-342100-00	2-SPEED LIFT AND LOWER BOX(L) ASSY.	1	
15	2125-520014-0C	2-SPEED WIRING HARNESS- BUTTONS	1	
16	1220-560002-00	INCHING SWITCH II	5	
17	1120-342002-00	HORN BUTTON	1	
18	1120-342005-00	PIN	2	
19	1120-342003-00	SPRING	2	
20	1120-342004-00	BUTTON BRACKET	1	

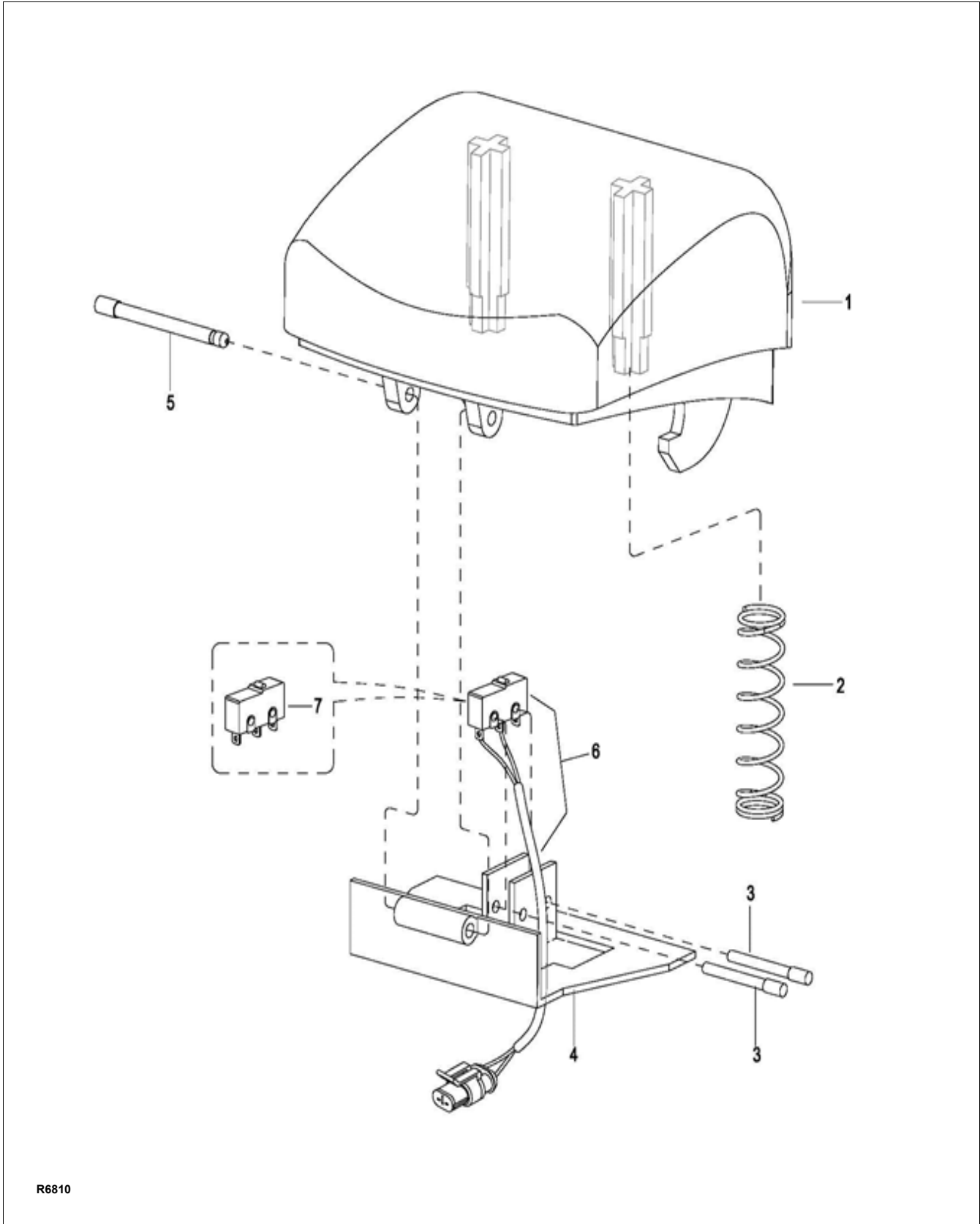

R6810

Figure 12-7 Emergency Reverse Switch Assembly - Used up to Serial Number 327120792 (Not used when Side Shift)

**EMERGENCY REVERSE SWITCH ASSEMBLY (NOT USED WHEN SIDE SHIFT)
USED UP TO SERIAL NUMBER 327120792 (NOT USED WHEN SIDE SHIFT)**

Pos.	Part Number	Description	Qty. Reqd.	Notes
1	1120-343002-00	COVER	1	
2	1120-343003-00	SPRING	2	
3	1120-342005-00	PIN	2	
4	1120-343001-0A	BRACKET	1	
5	1120-343004-00	PIN	1	
6	1220-520005-00	REVERSING SWITCH WIRE	1	Used up to 12-08-2010
6a	1220-520005-0C	REVERSING SWITCH WIRE	1	Used from 12-09-2010 to Serial Number 327120792
7	1220-560002-00	INCHING SWITCH II	1	

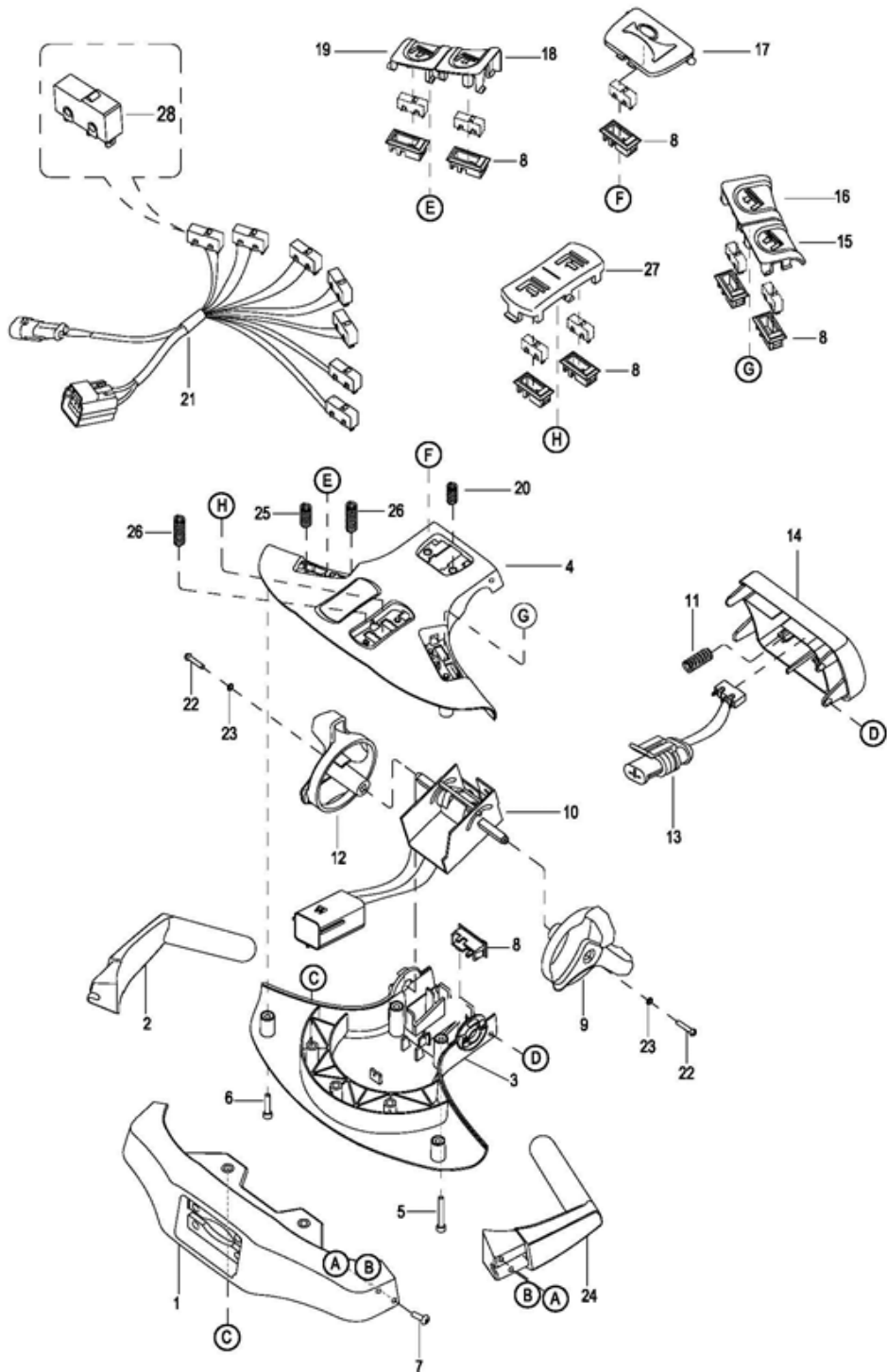

R8052

Figure 12-8 Control Head Assembly (For Side Shift) - Used up to serial number S2315284

**CONTROL HEAD ASSEMBLY (FOR SIDE SHIFT)
(USED UP TO SERIAL NUMBER S2315284)**

Pos.	Part Number	Description	Qty. Reqd.	Notes
--	1280-360000-10-B	CONTROL POD ASSEMBLY	1	
1	1280-360001-00	BRACKET	1	
2	1280-360002-00	HANDLE R	1	
3	1280-360004-00	COVER	1	
4	1280-360003-00	COVER	1	
5	0000-000320-00	SCREW M6×35	2	
6	0000-000032-00	SCREW M6×25	2	
7	0000-000498-00	SCREW M6×30	4	
8	1280-360013-00	BUTTON BRACKET	6	
9	1280-360006-00	CONTROL KNOB-L	1	
10	1220-520008-0C	WIRE HARNESS-ACCELERATOR	1	
11	1120-343003-00	SPRING	2	
12	1280-360005-00	CONTROL KNOB-R	1	
13	1220-520005-0C	WIRE HARNESS-REVERSING SWITCH	1	
14	1280-360012-00	BUTTON REVERSER	1	
15	1280-360009-00	LOWER BUTTON-L	1	
16	1280-360007-00	LIFTING BUTTON-L	1	
17	1280-360011-00	HORN BUTTON	1	
18	1280-360008-00	LIFTING BUTTON-R	1	
19	1280-360010-00	LOWER BUTTON-R	1	
20	1280-360014-00	SPRING	2	
21	2130-520003-40	WIRE HARNESS-BUTTONS	1	
22	0000-000037-00	SCREW M3×12	2	
23	0000-000038-00	LOCKWASHER Ø3	2	
24	1280-360017-00	HANDLE L	1	
25	1280-360015-00	SPRING II	2	
26	1280-360016-00	SPRING I	8	
27	1280-360018-00	SIDESWAY BUTTON	1	
28	1220-560002-00	INCHING SWITCH II	8	

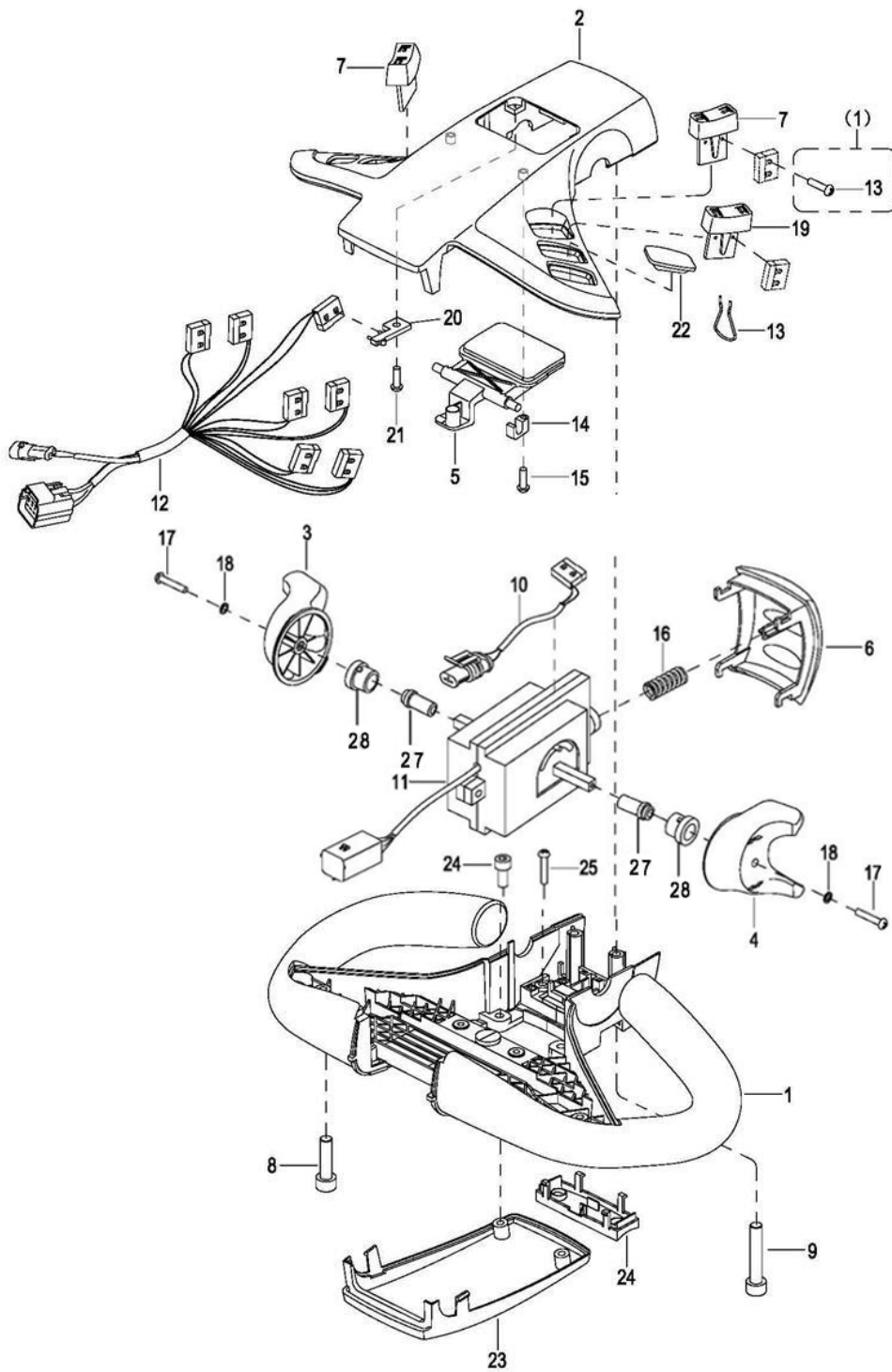

R8053

Figure 12-9 Control Head Assembly (For Side Shift) - Used from serial number S2315285

**CONTROL HEAD ASSEMBLY (FOR SIDE SHIFT)
(USED FROM SERIAL NUMBER S2315285)**

Pos.	Part Number	Description	Qty. Reqd.	Notes
--	2130-350000-40	CONTROL POS ASSEMBLY	1	
1	2333-340001-00	COVER	1	
2	2333-340002-00	CAP	1	
3	2333-340003-00	TRAVELING KNOB R	1	
4	2333-340004-00	TRAVELING KNOB L	1	
5	2333-340005-00	HORN BUTTON	1	
6	2333-340006-00	BUTTON REVERSER COVER	1	
7	2333-340015-00	DIRECTION BUTTON	2	
8	2333-340013-00	SCREW M5×30	2	
9	2333-340014-00	SCREW M5×55	2	
10	2333-520004-10	REVERSING SWITCH WIRE	1	
11	2333-520003-10	ACCELERATOR ASSEMBLY	1	
12	2130-520003-40	BUTTONS ASSEMBLY	1	
13	2333-340017-00	CLAMP	6	
14	2333-340009-00	MOUNTING SEAT	2	
15	2333-340012-00	SCREW ST2.9×9.5	2	
16	2333-340010-00	SPRING	1	
17	0000-000037-00	SCREW M3×12	2	
18	0000-000038-00	LOCKWASHER Ø3	2	
19	2333-340016-00	SIDESWAY BUTTON	2	
20	2333-340018-00	BRACKET	1	
21	2333-340019-00	SCREW M3×10	1	
22	2333-340020-00	COVER	4	
23	2333-340022-00	SEALING PLATE	1	
24	2333-340023-00	BUTTON	1	
25	2333-340024-00	SCREW M5×12	2	
26	2333-340025-00	SCREW ST2.9×20	2	
27	2333-340026-00	BUSHING	2	
28	2333-340027-00	BUSHING	2	

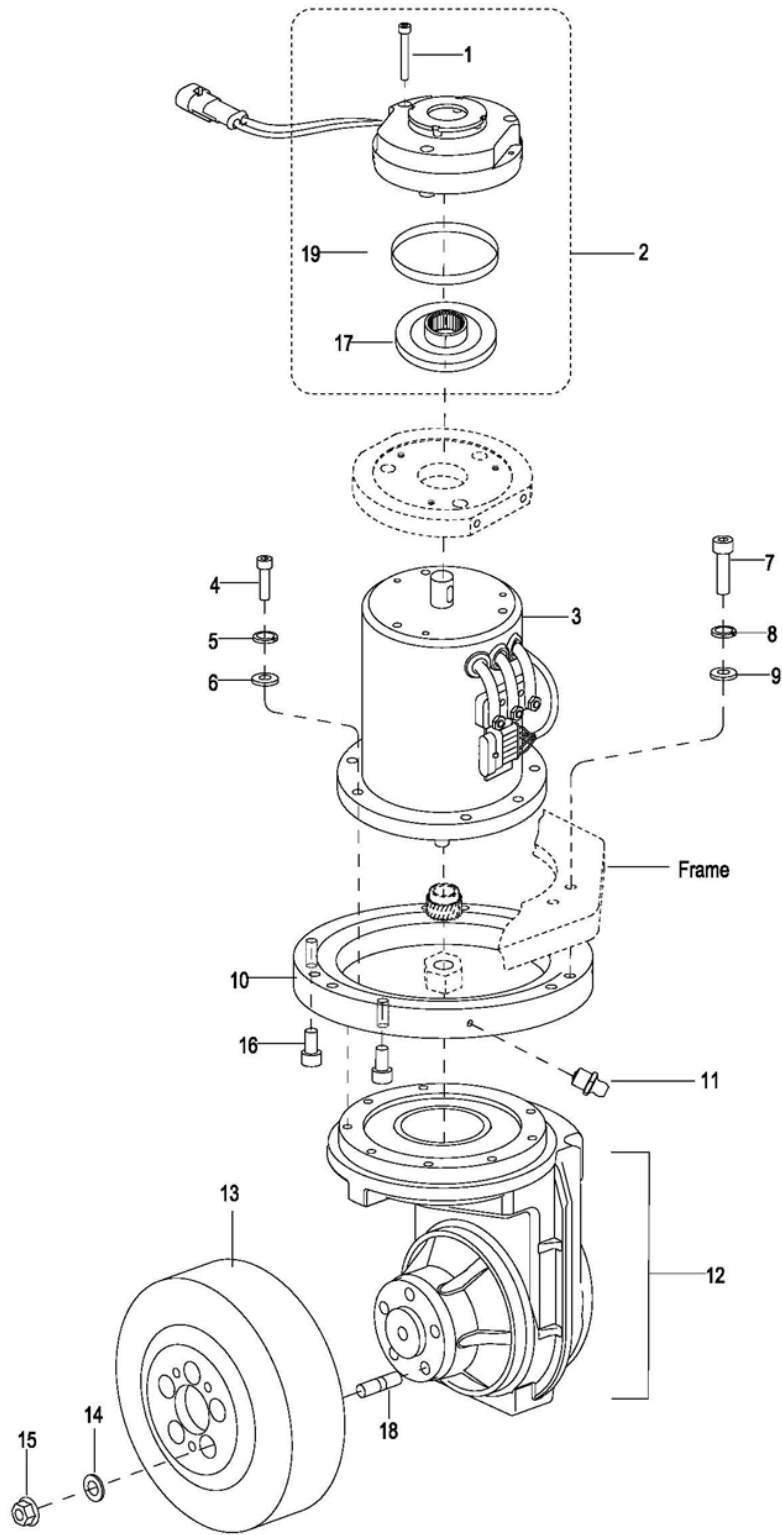

R6811

Figure 12-10 Transmission, Motor, Brake Assembly

TRANSMISSION, MOTOR, BRAKE ASSEMBLY

Pos.	Part Number	Description	Qty. Reqd.	Notes
1	0000-000027-00	SCREW M6×55	3	
2	1120-210000-10	BRAKE ASSEMBLY	1	
3	1120-220000-00	MOTOR ASSEMBLY	1	
4	0000-000154-00	SCREW M8×35	8	
5	0000-000159-00	LOCKWASHER Ø8	8	
6	0000-000176-00	FLATWASHER Ø8	8	
7	0000-000155-00	SCREW M10×40	6	
8	0000-000063-00	LOCKWASHER Ø10	6	
9	0000-000007-00	FLATWASHER Ø10	6	
10	1120-230000-00	BEARING	1	
11	0000-000013-00	GREASE FITTING M8	1	
12	1120-240000-10	GEAR CASE ASSEMBLY III	1	Used up to serial number S2214153 on PDS-30 and S2215044 on PDS-40. This is non serviceable. If replacing a complete gearbox to serviceable part # 1120-240000-30 you have to replace the gear set part # 1120-GB30-00.
--	1120-240014-00	DRIVE MOTOR GEAR	1	Pictured under the drive motor. This part # is only used for gearbox 1120-240000-10 (pos. # 12). For the drive motor gear for pos. # 12a see the Transmission Section in the parts break down.
12a	1120-240000-30	GEAR CASE ASSEMBLY IV	1	Used between serial number S2214154 - 327120531 on PDS-30 and between S2215045 - 327120531 on PDS-40. Ratio 22.07
12b	ZK12-240000-00	GEAR CASE ASSEMBLY IV	1	From serial # 327120532. Ratio 22.07
13	1120-200001-00	DRIVE WHEEL	1	Poly Wheel (Standard)
13a	1120-200001-20	DRIVE WHEEL	1	Traction Drive Wheel, Poly (Diamond X Siped)
13b	506161-11	DRIVE WHEEL	1	ONLY USED ON PDS-30: Non Marking Rubber, Diamond-X (Traction)
14	0000-000025-00	LOCKWASHER Ø12	5	From 12-17-2012 to serial # 327120531
14a	ZK12-240018-00	LOCKWASHER Ø12	5	Used from serial number 327120532
15	0000-001131-10	NUT M12×1.5	5	Used for gearbox 1120-240000-10
15a	0000-000157-00	NUT M12	5	Used for gearbox 1120-240000-30
15b	0000-001131-10	NUT M12	5	Used for gearbox ZK12-240000-00
16	0000-000070-00	SCREW M10×25	2	
17	1120-210002-00	BRAKE LINING	1	
18	4230-210001-00	DRIVE WHEEL STUD	5	Used for gearbox 1120-240000-10
18a	1120-240014-30	DRIVE WHEEL STUD	5	Used for gearbox 1120-240000-30
18b	ZK12-240003-00	DRIVE WHEEL STUD	5	Used for gearbox ZK12-240000-00
19	1120-211101-10	DUSTBAND	1	Used from serial number 3281500170

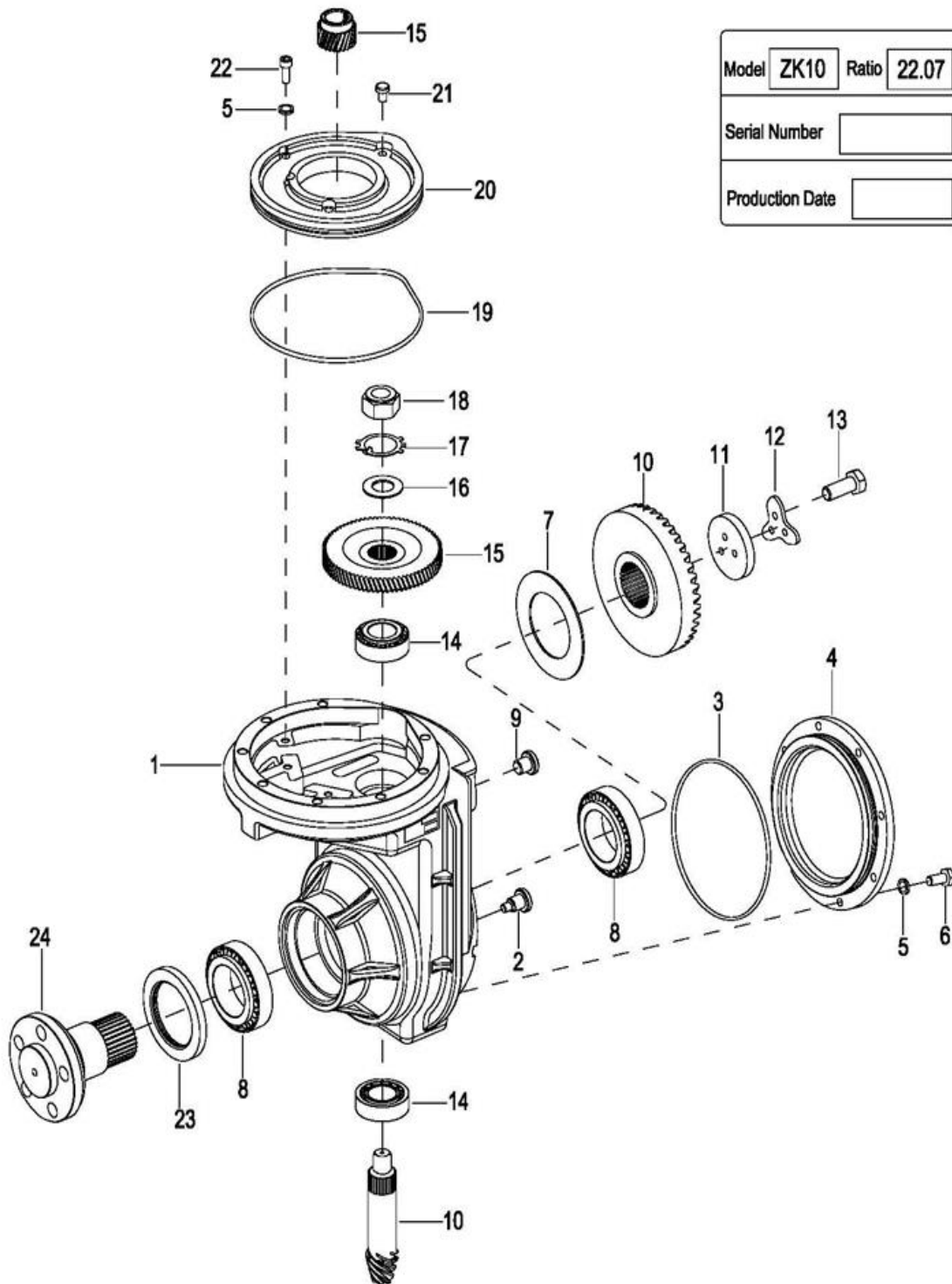

R8070

Figure 12-11 Transmission Used between serial number:
 S2214154 - 327120531 on PDS-30 and S2215045 - 327120531 on PDS-40.

TRANSMISSION

(Used between serial number: S2214154 - 327120531 on PDS-30 and S2215045 - 327120531 on PDS-40)

Pos.	Part Number	Description	Qty. Reqd.	Notes
--	1120-240000-30	GEARBOX ASSEMBLY	1	Ratio 22.07
1	1120-240001-30	GEAR CASE	1	
2	1120-240002-30	PLUG	1	
3	0000-000214-00	O-RING 135×3.1	1	
4	1120-240003-30	COVER	1	
5	0000-000056-00	LOCKWASHER Ø6	12	
6	0000-000259-00	BOLT M6×16	8	
7	1120-240019-30	WASHER	A.R.	As Required
8	0000-000961-00	BEARING	2	
9	1120-240005-30	PLUG	1	
10	1120-GB30-10	SPIRAL BEVEL GEAR SET	1	Includes 2 gears
11	1120-240007-30	WASHER	1	
12	1120-240008-30	LOCKING PLATE	1	
13	0000-000277-00	BOLT M8×25	3	
14	0000-001054-00	BEARING	2	
15	1120-GB30-00	GEAR	1	Includes 2 gears
16	0000-000379-00	FLATWASHER Ø14	1	
17	0000-001055-00	WASHER Ø14	1	
18	0000-001056-00	NUT M14×1.5	1	
19	0000-000211-00	O-RING 150×3.1	1	
20	1120-240010-30	COVER	1	
21	1120-240011-30	PLUG	1	
22	0000-000055-00	SCREW M6×16	4	
23	1120-240017-30	SEAL WASHER TC80×65×8	1	
24	1120-240013-30	OUTPUT SHAFT	1	

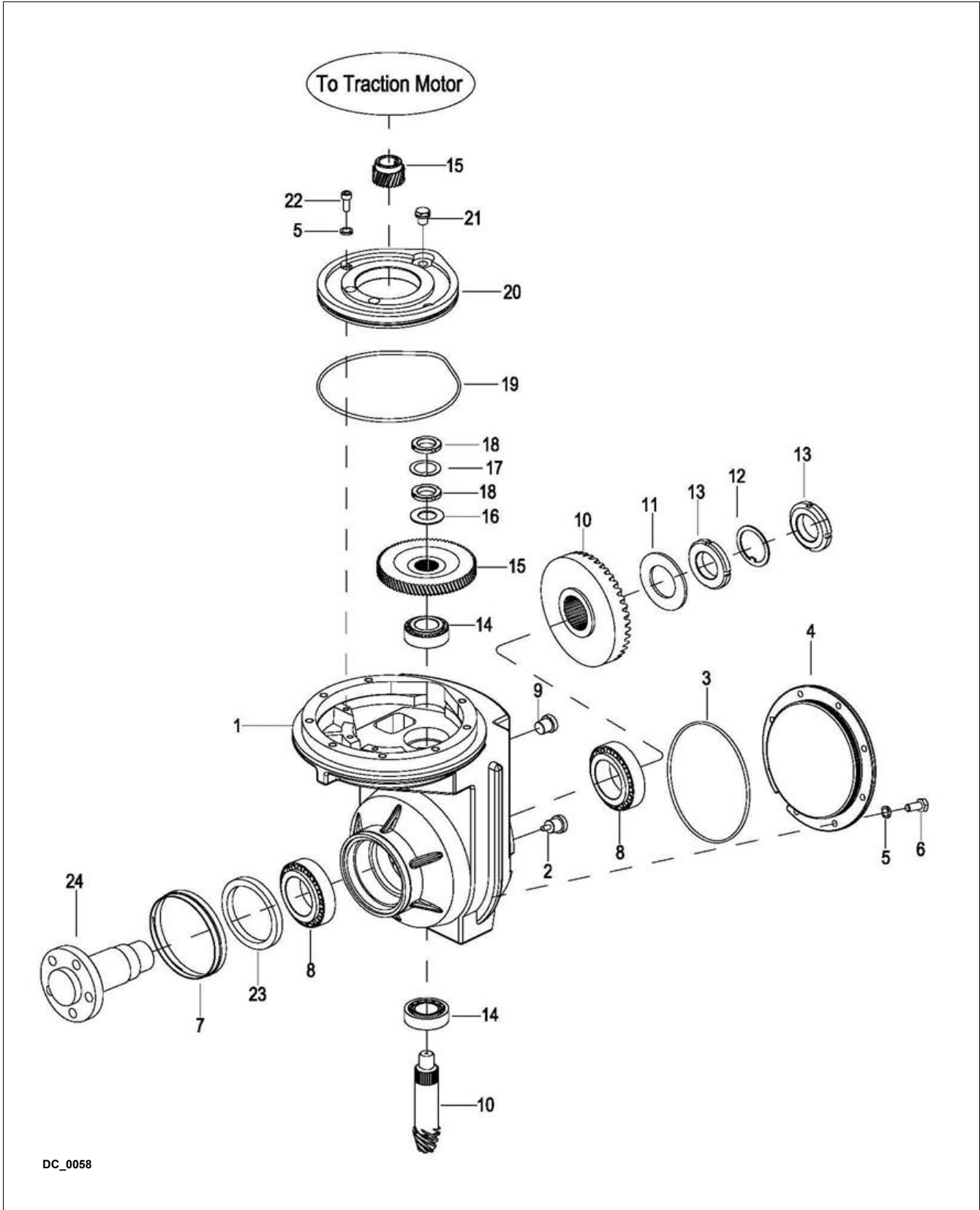

DC_0058

Figure 12-12 Transmission Used from serial number 327120532

TRANSMISSION

Used from serial number 327120532

Pos.	Part Number	Description	Qty. Reqd.	Notes
--	ZK12-240000-00	GEARBOX ASSEMBLY	1	Ratio 22.07
1	ZK12-240004-00	GEAR CASE	1	
2	ZK12-240016-00	PLUG	1	
3	0000-000214-00	O-RING 135×3.1	1	
4	ZK12-240006-00	COVER	1	
5	0000-000056-00	LOCKWASHER Ø6	12	
6	0000-000259-00	BOLT M6×16	8	
7	ZK12-240010-00	PROTECTIVE SLEEVE	1	
8	0000-000961-00	BEARING	2	
9	ZK12-240017-00	PLUG	1	
10	ZK12-GB30-10	SPIRAL BEVEL GEAR SET	1	Used between serial numbers 327120532 - 327150591 Includes 2 gears
10a	ZK12-GB30-1A	SPIRAL BEVEL GEAR SET	1	Used from serial number 327150592, Incl. 2 gears.
11	ZK12-240015-00	WASHER 65x36.5x3	1	
12	ZK12-240021-00	WASHER Ø36	1	
13	3030-110000-06	NUT M36	3	
14	0000-001054-00	BEARING	2	
15	ZK12-GB30-00	GEAR	1	Includes 2 gears
16	0000-000379-00	FLATWASHER Ø14	1	
17	ZK12-240020-00	WASHER Ø14	1	
18	3030-070000-04	NUT M14	1	
19	0000-000211-00	O-RING 150×3.1	1	
20	ZK12-240005-00	COVER	1	
21	ZK12-240019-00	PLUG	1	
22	0000-000055-00	SCREW M6×16	4	
23	3060-030000-17	SEAL WASHER TC80×65×8	1	
24	ZK12-240007-00	OUTPUT SHAFT	1	Used between serial numbers 327120532 - 327150591
24a	ZK12-240007-0A	OUTPUT SHAFT	1	Used from serial number 327150592

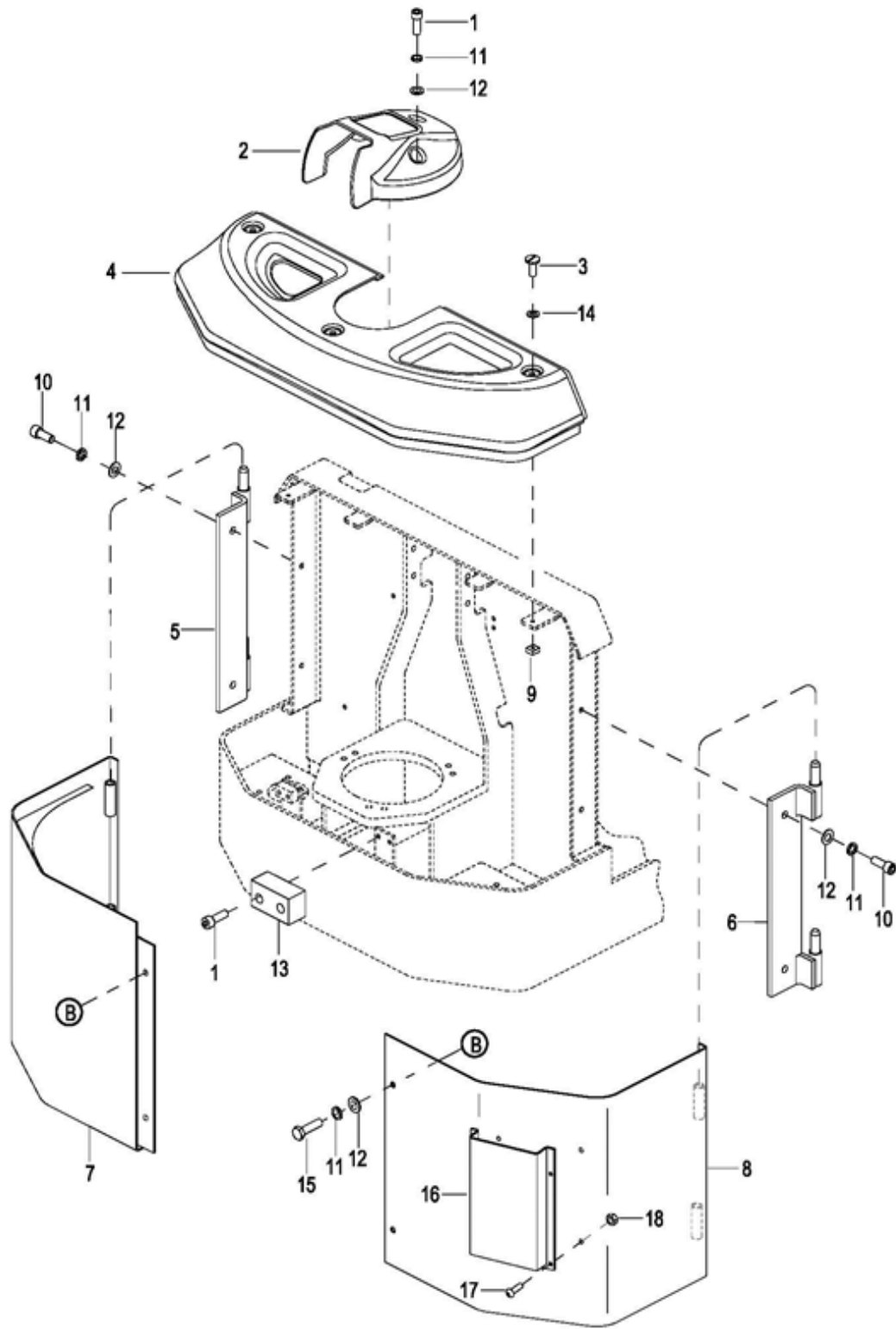

R6813

Figure 12-13 Compartment

COMPARTMENT

Pos.	Part Number	Description	Qty. Reqd.	Notes
1	0000-000433-00	SCREW M8×12	7	
2	1280-300005-00	MIDDLE COVER	1	
3	1118-100004-10	SCREW	3	
4	2130-190001-00	UPPER COVER	1	
5	2130-172000-00	BRACKET L	1	
6	2130-182000-00	BRACKET R	1	
7	2130-171000-00	COVER L	1	
8	2130-181000-00	COVER R	1	Used up to serial number 326110886
8a	2130-181000-0A	COVER R	1	Used from serial number 326110887
9	1220-150005-00	NUT M8	2	
10	0000-000322-00	SCREW M8×25	4	
11	0000-000159-00	LOCKWASHER Ø8	9	
12	0000-000194-00	FLATWASHER Ø8	9	
13	2125-600005-00	BUFFER BLOCK	2	
14	2214-150002-00	WASHER	3	
15	0000-000242-00	BOLT M8×16	2	
16	1146-151002-30	MANUAL HOLDER	1	
17	0000-000119-00	SCREW M5×12	4	Used from serial number 326110887
18	0000-000546-00	NUT M5	4	

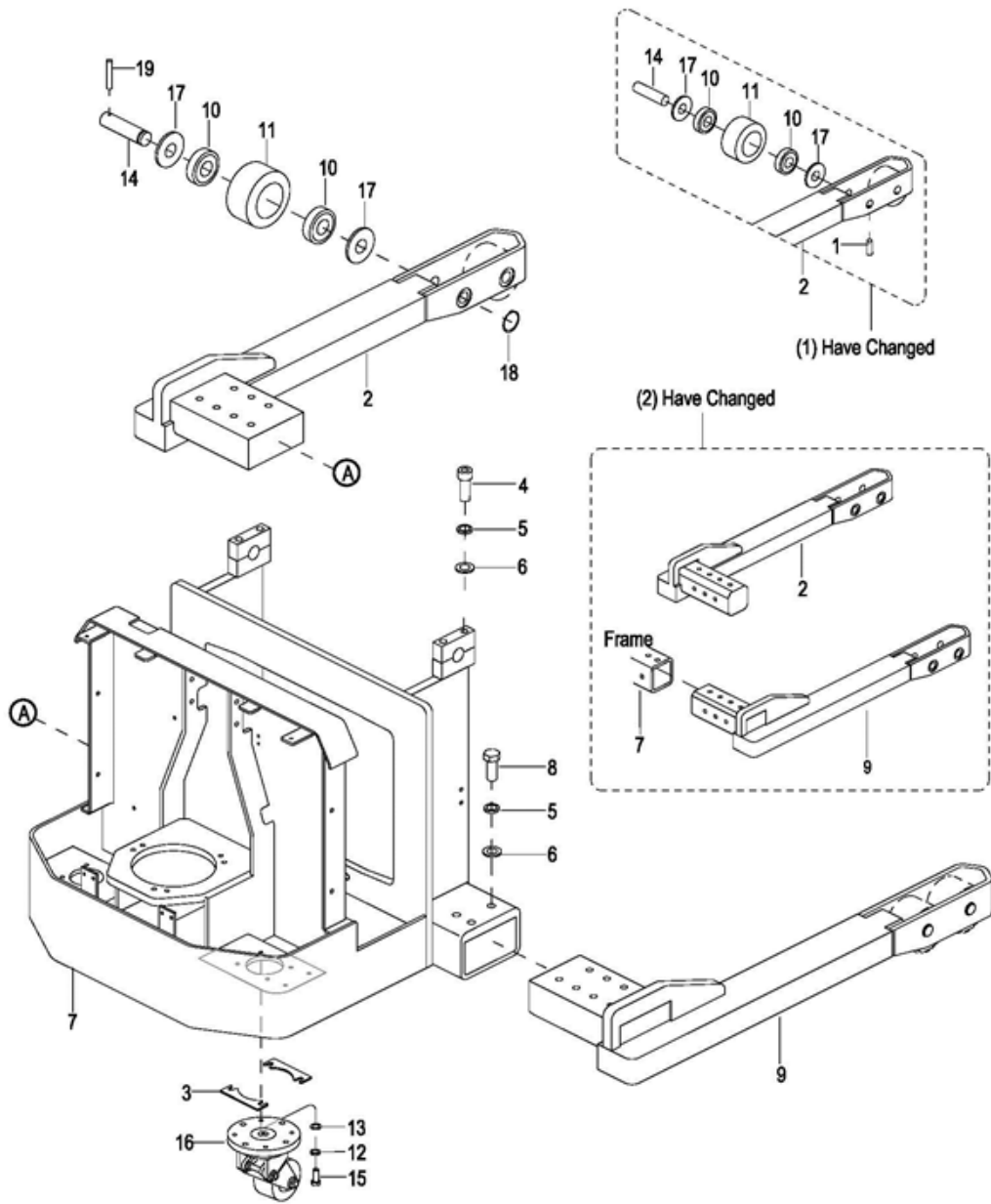

R6814

Figure 12-14 Adjustable Straddle (PDS-30 Only)

ADJUSTABLE STRADDLE (PDS-30 ONLY)

Pos.	Part Number	Description	Qty. Reqd.	Notes
1	0000-000015-00	SCREW M6×10	4	Used up to serial number S2020023
2	2130-120000-00	END FRAME L	1	Used up to serial number S2020023, Not when Side Shift
2a	2130-120000-0A	END FRAME L	1	Used from serial number S2020023 to S2118100, Not when Side Shift
2b	2130-120000-0B	END FRAME L	1	Used from serial number S2118101, Not when Side Shift
2c	2130-120000-40	END FRAME L	1	Used when Side Shift option on truck
3	2140-140005-00	WASHER	A.R.	As Requested
4	0000-000432-00	SCREW M16×80	4	
5	0000-000191-00	LOCKWASHER Ø16	10	
6	0000-000220-00	FLATWASHER Ø16	10	
7	2130-110000-00	FRAME	1	Used up to serial number S2118100, Not when Side Shift
7a	2130-110000-0A	FRAME	1	Used from serial number S2118101, Not when Side Shift
7b	2130-110000-10	FRAME	1	Used when Telescopic Mast and Side Shift option
7c	2130-110000-40	FRAME	1	Used when Trimast and Side Shift option
8	0000-000703-00	BOLT M16×45	6	Used up to serial number S2118100
8a	0000-000963-00	BOLT M16×60	6	Used from serial number S2118101
9	2130-130000-00	END FRAME R	1	Used up to serial number S2020023
9a	2130-130000-0A	END FRAME R	1	Used from serial number S2020023 to S2118100
9b	2130-130000-0B	END FRAME R	1	Used from serial number S2118101
9c	2130-130000-40	END FRAME R	1	Used when Side Shift option on truck
10	0000-000100-00	BEARING	8	
11	2130-140001-00	LOAD WHEEL	4	
12	0000-000159-00	LOCKWASHER Ø8	8	
13	0000-000176-00	FLATWASHER Ø8	8	

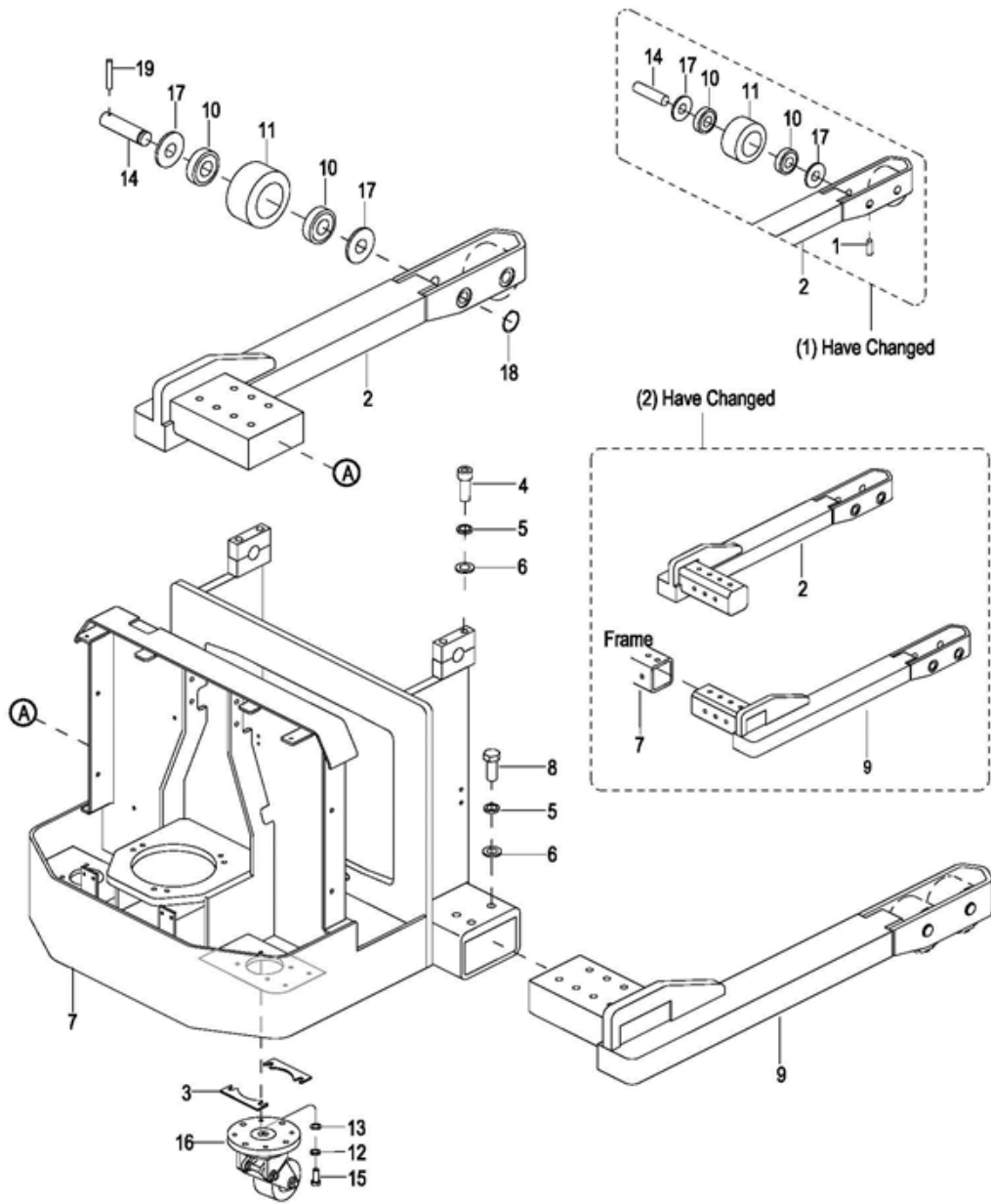

R6814

Figure 12-14 Adjustable Straddle (PDS-30 Only) - Continued

ADJUSTABLE STRADDLE (PDS-30 ONLY) - CONTINUED

Pos.	Part Number	Description	Qty. Reqd.	Notes
14	2130-140002-00	SHAFT	4	Used up to serial number S2020022
14a	2130-140002-0A	SHAFT	4	Used from serial number S2020023
15	0000-000277-00	BOLT M8×25	8	
16	1120-140000-00	CASTER ASSEMBLY I	2	Used up to serial number S2118100
16a	1118-140000-00	CASTER ASSEMBLY I	2	Used from serial number S2118101
17	2130-140003-00	WASHER	8	
18	0000-000294-00	RETAINING RING Ø25	4	Used from 10-17-2011
19	0000-000654-00	ROLL PIN Ø4×45	4	Used from 10-17-2011

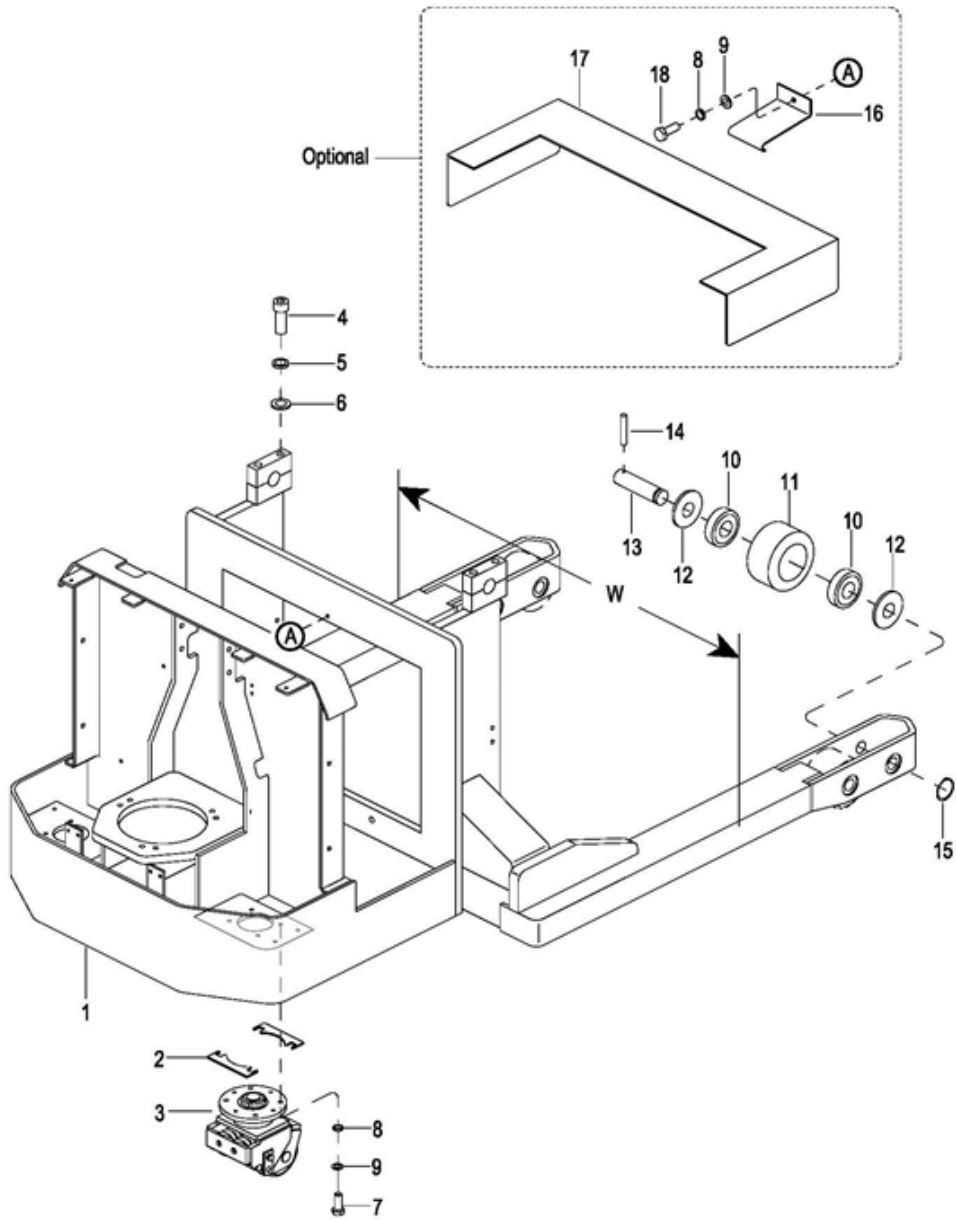

R6844

Figure 12-15 Fixed Straddle (PDS 40 ONLY)

FIXED STRADDLE (PDS 40 ONLY)

Pos.	Part Number	Description	Qty. Reqd.	Notes
1	--	FRAME	1	Contact Big Lift LLC
2	2140-140005-00	WASHER	A.R.	As Required
3	2140-140000-0A	CASTER ASSEMBLY II	2	
4	0000-000432-00	SCREW M16×80	4	
5	0000-000191-00	LOCKWASHER Ø16	4	
6	0000-000220-00	FLATWASHER Ø16	4	
7	0000-000277-00	BOLT M8×25	8	
8	0000-000159-00	LOCKWASHER Ø8	8	
9	0000-000176-00	FLATWASHER Ø8	8	
10	0000-000100-00	BEARING	8	
11	2130-140001-00	LOAD WHEEL	4	
12	2130-140003-00	WASHER	8	
13	2130-140002-0A	SHAFT	4	
14	0000-000654-00	ROLL PIN Ø4×45	4	
15	0000-000294-00	RETAINING RING Ø25	4	
16	2140-100002-00	BATTERY CLAMP	1	Optional - available from 01-03-2013
17	2140-101000-00	BATTERY CLIP	1	Optional - available from 01-03-2013
18	0000-000242-00	BOLT M8×16	1	Optional - available from 01-03-2013

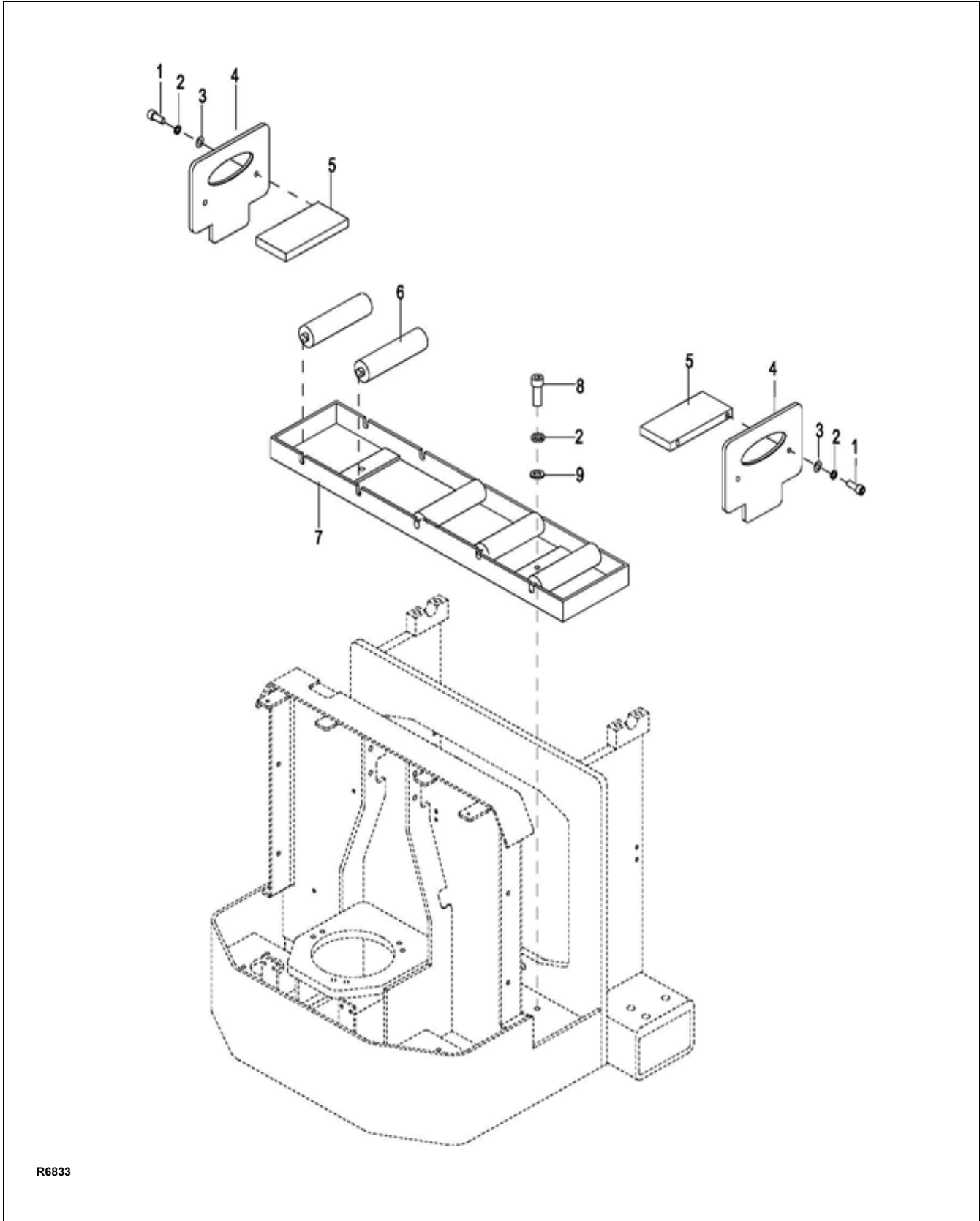

R6833

Figure 12-16 Battery Compartment

BATTERY COMPARTMENT

Pos.	Part Number	Description	Qty. Reqd.	Notes
1	0000-000322-00	SCREW M8×25	4	
2	0000-000159-00	LOCKWASHER Ø8	6	
3	0000-000176-00	FLATWASHER Ø8	4	
4	2130-160001-00	BAFFLE-PLATE	2	
5	2130-160002-00	BAFFLE-BLOCK	2	
6	2125-102200-0A	ROLLER	5	Optional
7	2130-151000-00	SLIDEWAY FRAME	1	Optional
8	0000-000321-00	SCREW M8×20	2	Optional
9	0000-000194-00	FLATWASHER Ø8	2	Optional

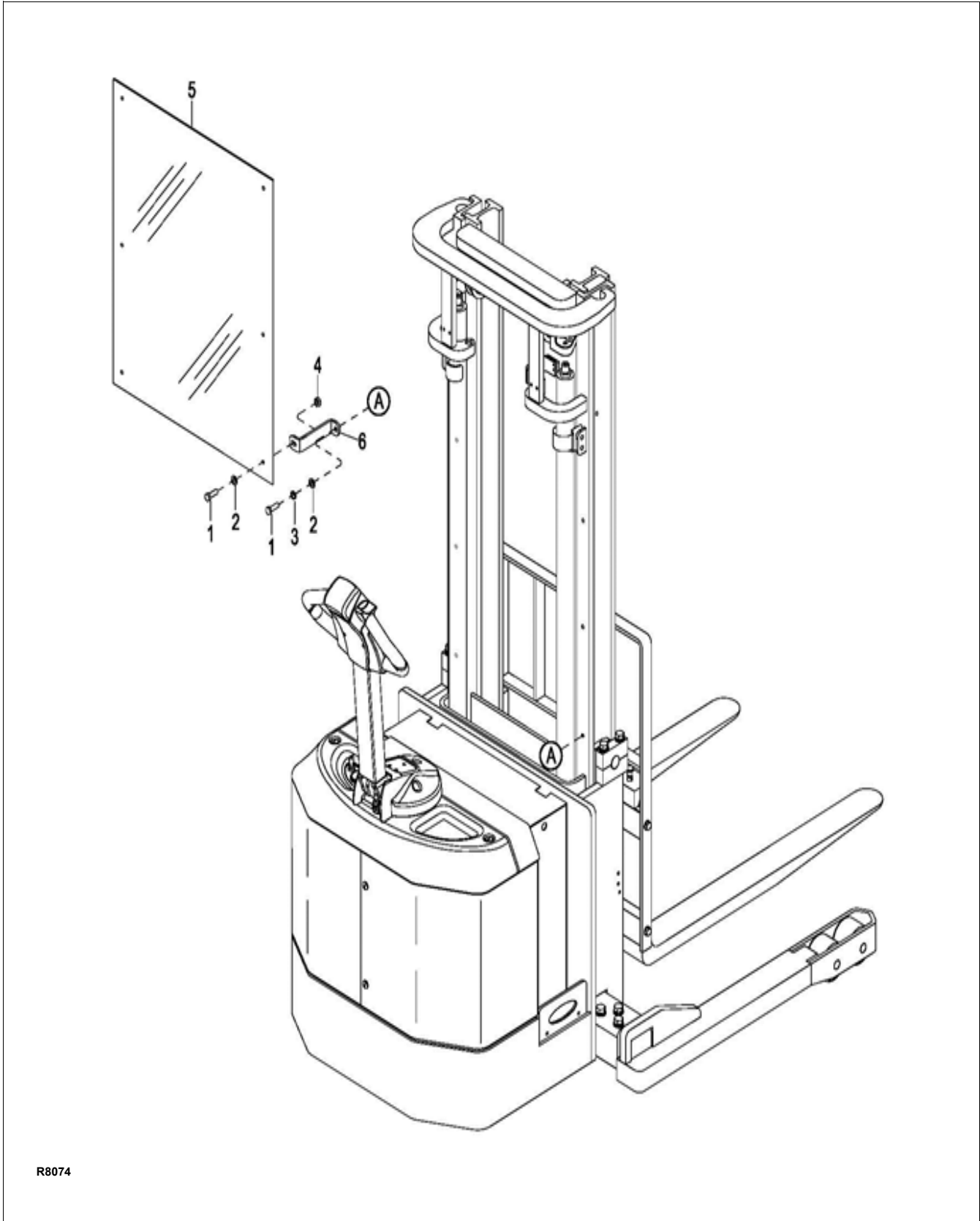

R8074

Figure 12-17 Windshield (Telescopic)

WINDSHIELD (TELESCOPIC)

Pos.	Part Number	Description	Qty. Reqd.	Notes
1	0000-000871-00	BOLT M8×140	6	Used up to serial number S2121139
1a	0000-000242-00	BOLT M8×16	12	Used from serial number S2121140
2	0000-000176-00	FLATWASHER Ø8	12	
3	0000-000159-00	LOCKWASHER Ø8	6	
4	0000-000550-00	NUT M8	6	
5	2130-600001-00-01	WINDSHIELD	1	Used for lift height 104" - Used up to serial number S2121139
5a	2130-600001-0A-01	WINDSHIELD	1	Used for lift height 104" - Used between serial number S2121140 - 3281500713
5b	2130-600001-BP-01	WINDSHIELD	1	Used for lift height 104" - Used from serial number 3281500714
5c	2130-600001-00-03	WINDSHIELD	1	Used for lift height 126" - Used up to serial number S2121139
5d	2130-600001-0A-03	WINDSHIELD	1	Used for lift height 126" - Used between serial number S2121140 - 3281500713
5e	2130-600001-BP-03	WINDSHIELD	1	Used for lift height 126" - Used from serial number 3281500714
5f	2130-600001-00-04	WINDSHIELD	1	Used for lift height 142" - Used up to serial number S2121139
5g	2130-600001-0A-04	WINDSHIELD	1	Used for lift height 142" - Used between serial number S2121140 - 3281500713
5h	2130-600001-BP-04	WINDSHIELD	1	Used for lift height 142" - Used from serial number 3281500714
6	2214-650002-60	ROUND TUBE	6	Used up to serial number S2121139
6a	2125-600009-30	PLATE	6	Used between serial number S2121140 - 3281500713
6b	2130-600009-00	PLATE	6	Used between serial number S2121140 - 3281500713

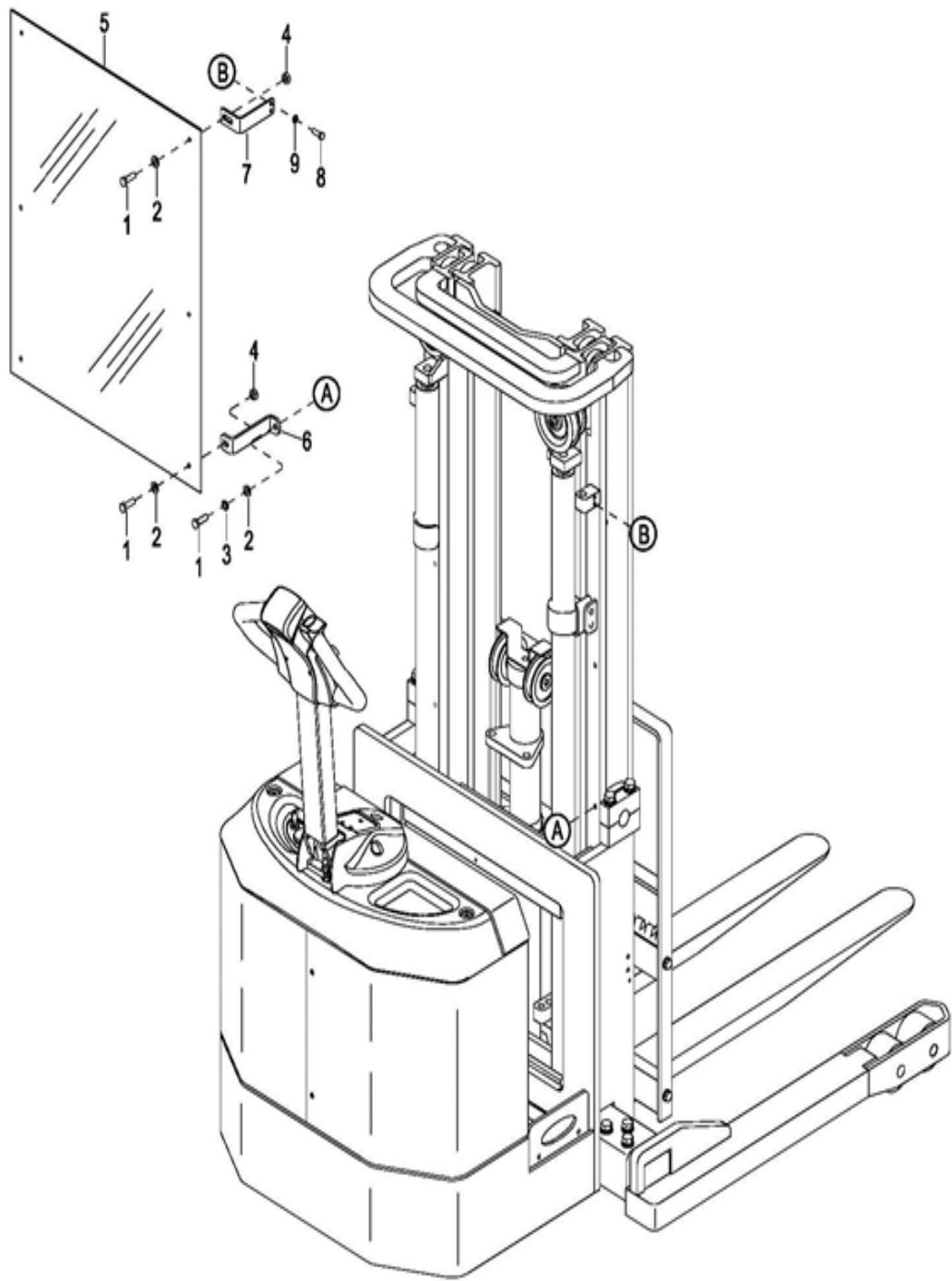

R8075

Figure 12-18 Windshield (TRIMAST)

WINDSHIELD (TRIMAST)

Pos.	Part Number	Description	Qty. Reqd.	Notes
1	0000-000242-00	BOLT M8×16	10	
2	0000-000176-00	FLATWASHER Ø8	4	
3	0000-000159-00	LOCKWASHER Ø8	10	
4	0000-000550-00	NUT M8	6	
5	2130-600001-30-01	WINDSHIELD	1	Used for lift height 157" - Used up to serial number 3281500713
5a	2125-600008-BP-01	WINDSHIELD	1	Used for lift height 157" - Used from serial number 3281500714
5	2130-600001-30-02	WINDSHIELD	1	Used for lift height 177" - Used up to serial number 3281500713
5	2125-600008-BP-02	WINDSHIELD	1	Used for lift height 177" - Used from serial number 3281500714
6	2125-600009-30	BRACKET	4	
7	2214-650005-60	BRACKET	2	
8	0000-000259-00	BOLT M6×16	4	
9	0000-000056-00	LOCKWASHER Ø6	4	
10	2214-150002-00	WASHER	6	Not pictured

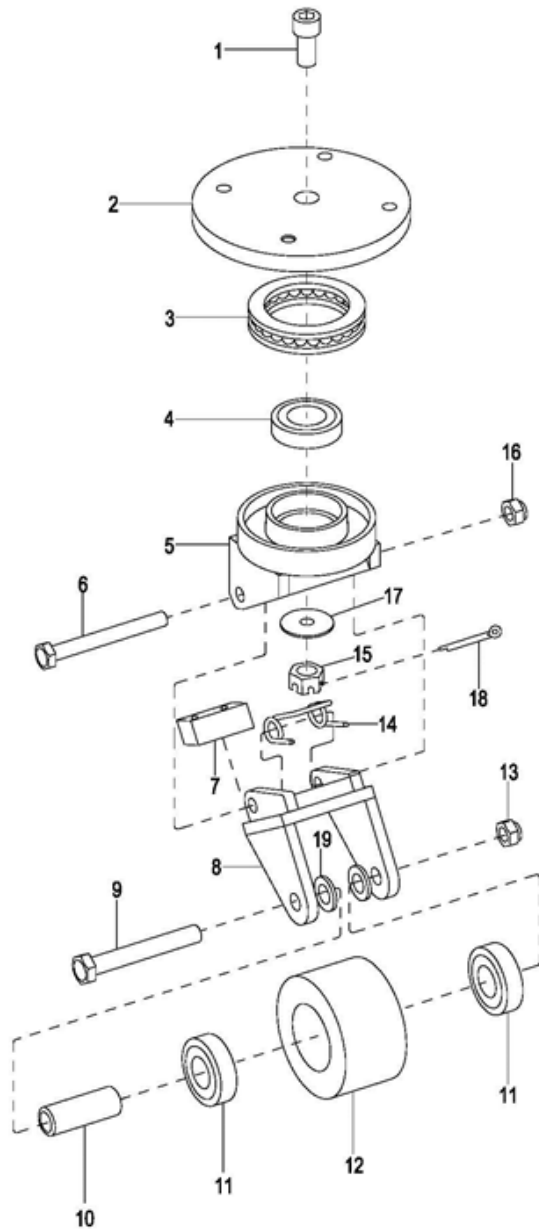

R6834

Figure 12-19 Caster for Adjustable Straddle (PDS 30 Only) - Up to serial number S2118100

**CASTER FOR ADJUSTABLE STRADDLE (PDS 30 ONLY)
(UP TO SERIAL NUMBER S2118100)**

Pos.	Part Number	Description	Qty. Reqd.	Notes
--	1120-140000-00	CASTER ASSEMBLY I	1	2 per truck
1	1120-140002-00	SCREW M10×25	1	
2	1120-140001-00	CASTER SUPPORT	1	
3	0000-000164-00	BEARING	1	
4	0000-000178-00	BEARING	1	
5	1120-141000-00	CASTER SUPPORT	1	
6	0000-000709-00	BOLT M10×95	1	
7	1120-140003-00	RUBBER	1	
8	1120-142000-00	WHEEL BRACKET	1	
9	0000-000495-00	BOLT M12×85	1	
10	1120-143001-00	SHAFT	1	
11	0000-000020-00	BEARING	2	
12	1120-143003-00	BLANCE WHEEL	1	
13	0000-000057-00	NUT M12	1	
14	1120-140004-00	SPRING	1	
15	0000-000174-00	NUT M10	1	
16	0000-000426-00	NUT M10	1	
17	0000-000175-00	FLATWASHER Ø10	1	
18	0000-000296-00	COTTER PIN Ø2×20	1	
19	0000-000435-00	FLATWASHER Ø20	2	

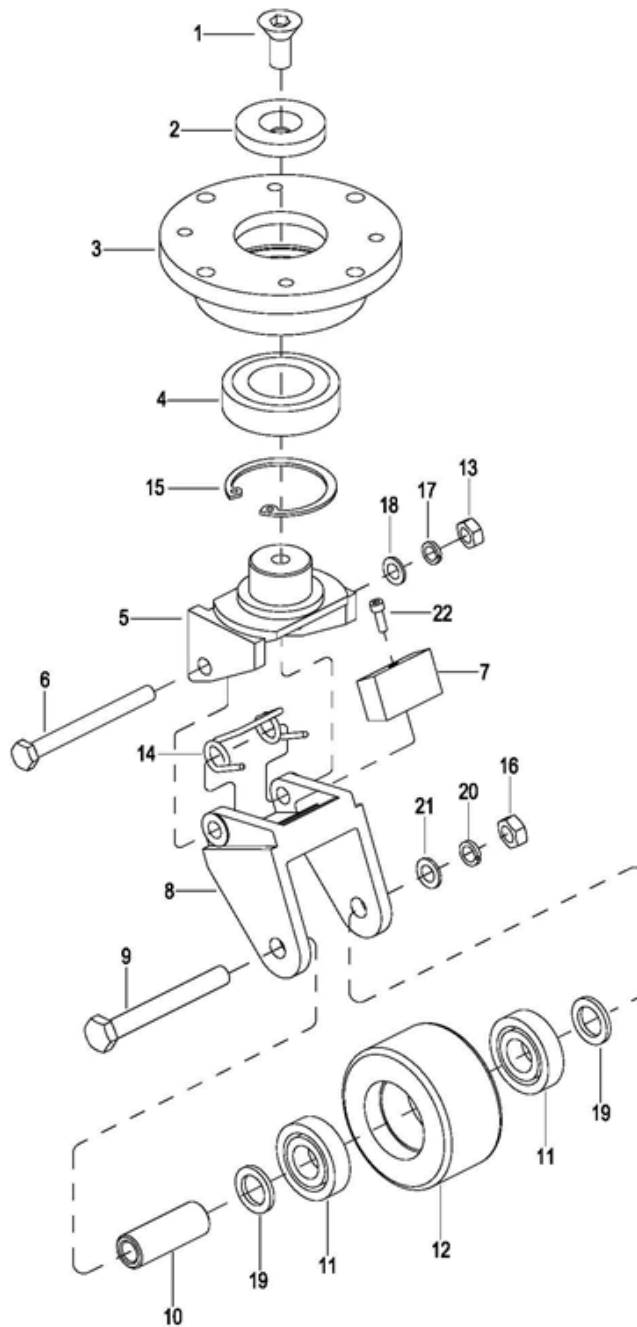

R8054

Figure 12-20 Caster for Adjustable Straddle (PDS 30 Only) - From serial number S2118101

**CASTER FOR ADJUSTABLE STRADDLE (PDS 30 ONLY)
(FROM SERIAL NUMBER S2118101)**

Pos.	Part Number	Description	Qty. Reqd.	Notes
--	1118-140000-00	CASTER ASSEMBLY II	1	2 per truck
1	0000-000985-00	SCREW M10×20	1	
2	1118-140003-00	PLATE	1	
3	1118-140001-00	CASTER SUPPORT	1	
4	0000-000986-00	BEARING	1	
5	1118-140002-00	CASTER SUPPORT	1	
6	0000-000168-00	BOLT M10×90	1	
7	1120-140003-00	PU BLOCK	1	
8	1120-142000-00	WHEEL BRACKET	1	
9	0000-000495-00	BOLT M12×85	1	
10	1120-143001-00	SHAFT	1	
11	0000-000020-00	BEARING	2	
12	1120-143003-00	PU WHEEL	1	
13	0000-000054-00	NUT M10	1	
14	1120-140004-00	SPRING	1	
15	0000-000987-00	ELASTIC COLLAR Φ80	1	
16	0000-000165-00	NUT M12	1	
17	0000-000063-00	LOCKWASHER Ø10	1	
18	0000-000007-00	FLATWASHER Ø10	1	
19	0000-000435-00	FLATWASHER Ø20	2	
20	0000-000060-00	LOCKWASHER Ø12	1	
21	0000-000373-00	FLATWASHER Ø12	1	
22	0000-000004-00	SCREW M5×12	1	

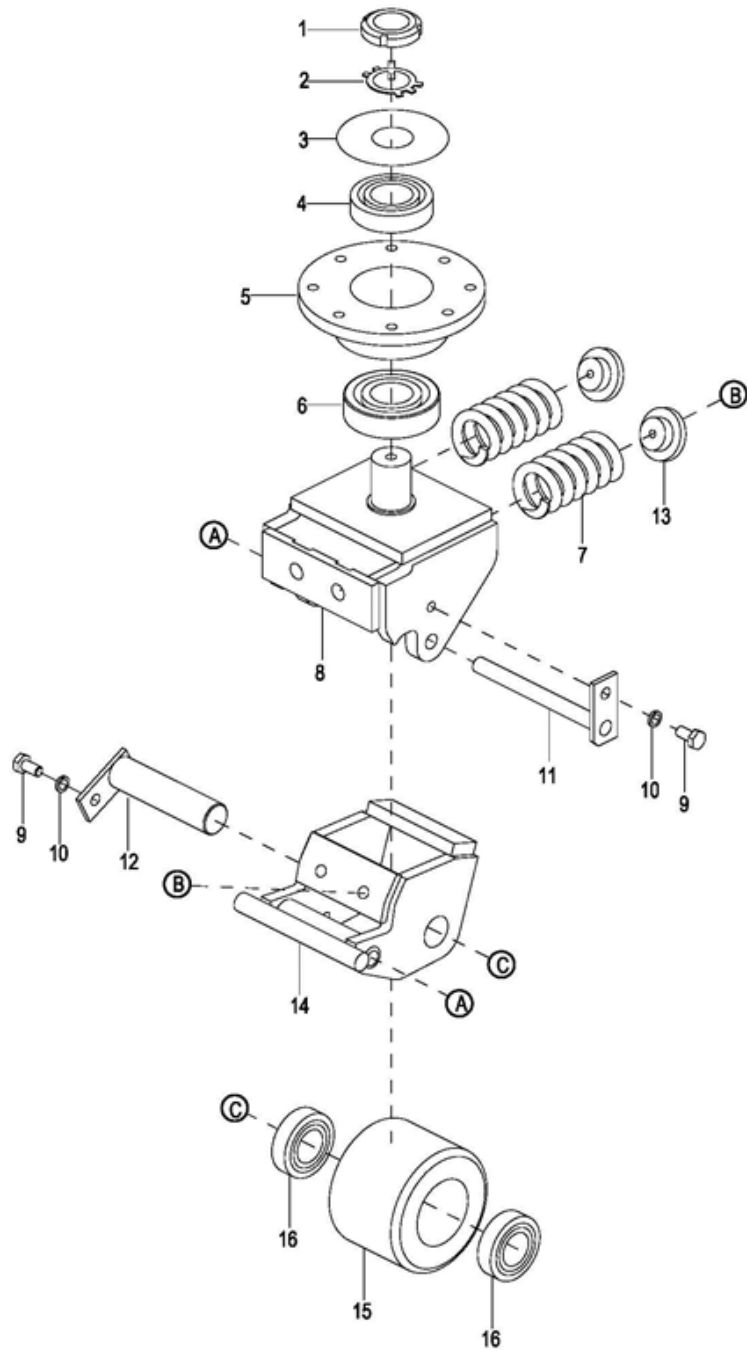

R6845

Figure 12-21 Caster Fixed Straddle (PDS 40 Only)

CASTER FIXED STRADDLE (PDS 40 ONLY)

Pos.	Part Number	Description	Qty. Reqd.	Notes
--	2140-140000-0A	CASTER ASSEMBLY II	1	2 per truck
1	0000-000093-00	NUT M27×1.5	1	
2	0000-000094-00	WASHER Ø27	1	
3	1220-140001-00	SNAP RING	1	
4	0000-000420-00	BEARING	1	
5	2140-140002-0A	BEARING BLOCK	1	
6	0000-000421-00	BEARING	1	
7	2140-140004-00	SPRING	2	
8	2140-141000-00	YOKE	1	
9	0000-000242-00	BOLT M8×16	2	
10	0000-000159-00	LOCKWASHER Ø8	2	
11	2140-142000-00	HINGE PIN	1	
12	2140-145000-00	SHAFT	1	
13	2140-140003-00	SHAFT	2	
14	2140-143000-00	YOKE	1	
15	2140-144002-00	PU WHEEL	1	
16	0000-000424-00	BEARING	2	

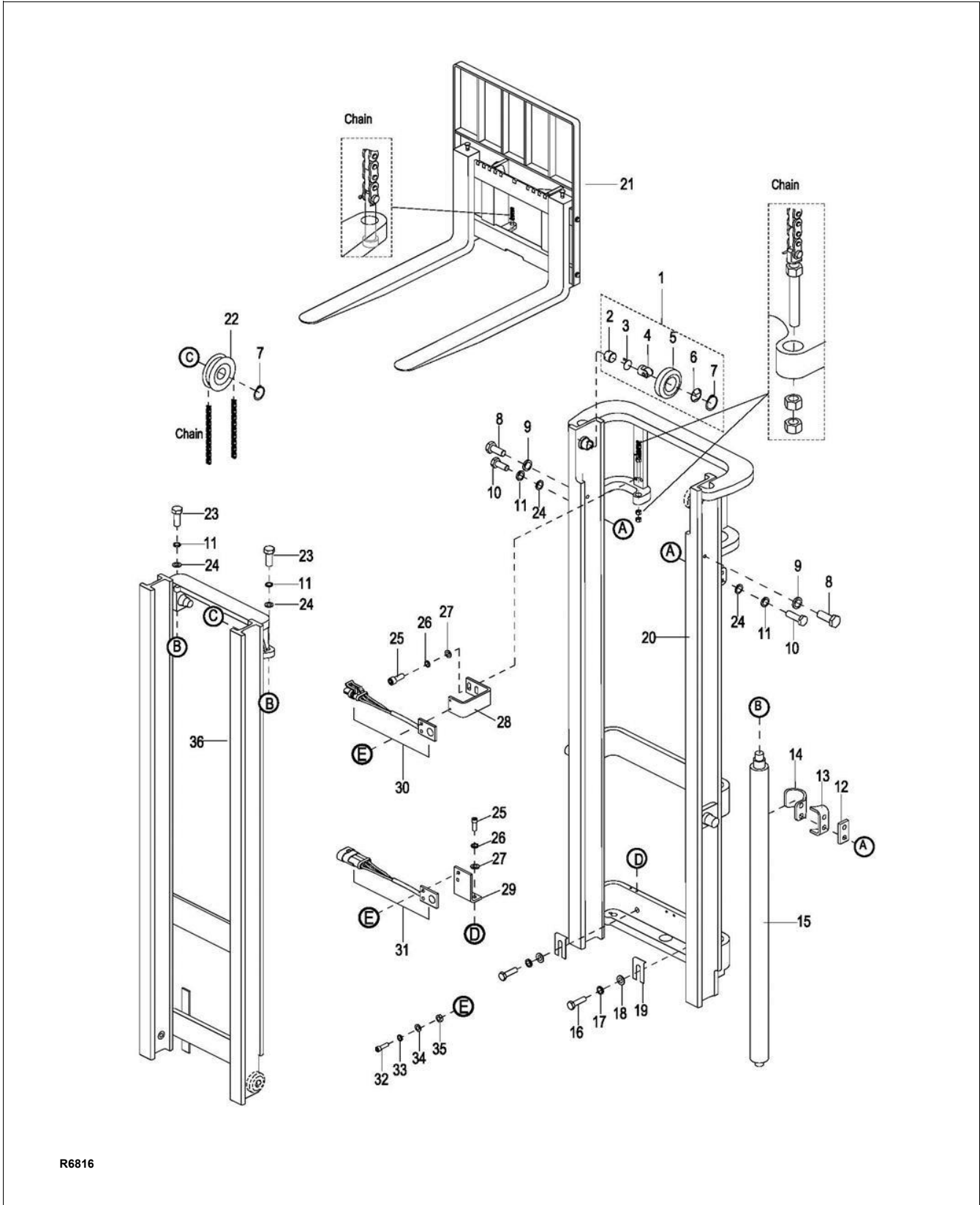

Figure 12-22 Elevation System (Telescopic) - Used up to Serial Number S2112138

ELEVATION SYSTEM (TELESCOPIC) - USED UP TO SERIAL NUMBER S2112138

Pos.	Part Number	Description	Qty. Reqd.	Notes
1	2125-612000-00	ROLLER ASSEMBLY	4	
2	2125-612004-00	SCREW	4	
3	2125-612007-00	SNAP RING	4	
4	2125-612002-00	ASSISTANT ROLLER	4	
5	2125-612001-00	MAIN ROLLER ASSEMBLY	4	
6	2125-612005-00	DUST SNAP	4	
7	0000-000183-00	RETAINER RING Ø35	6	
8	0000-000285-00	BOLT M12×35	2	
9	0000-000060-00	LOCKWASHER Ø12	2	
10	0000-000283-00	BOLT M10×35	4	
11	0000-000063-00	LOCKWASHER Ø10	6	
12	2214-600005-00	WASHER	A.R.	As Required
13	2214-600004-00	CYLINDER BRACKET	2	
14	2214-600003-00	CYLINDER CLIP	2	
15	2130-410000-00-01	LIFT CYLINDER ASSEMBLY	2	Used for lift height 104"
15	2130-410000-00-02	LIFT CYLINDER ASSEMBLY	2	Used for lift height 126"
15	2130-410000-00-03	LIFT CYLINDER ASSEMBLY	2	Used for lift height 142"
16	0000-000622-00	BOLT M16×40	2	
17	0000-000191-00	LOCKWASHER Ø16	2	
18	0000-000190-00	FLATWASHER Ø16	2	
19	2214-600006-00	WASHER	A.R.	As Required
20	2130-610000-00-01	OUTER MAST	1	Used for lift height 104"
20a	2130-610000-00-02	OUTER MAST	1	Used for lift height 126"
20b	2130-610000-00-03	OUTER MAST	1	Used for lift height 142"
21	SEE FORK CARRIAGE	FORK CARRIAGE ASSEMBLY	1	See Telescopic Fork Carriage Section
22	2214-600001-00	CHAIN ROLLER	2	
23	0000-000244-00	BOLT M10×30	2	
24	0000-000071-00	FLATWASHER Ø10	6	
25	0000-000109-00	SCREW M8×16	4	
26	0000-000159-00	LOCKWASHER Ø8	4	
27	0000-000176-00	FLATWASHER Ø8	4	
28	2130-500002-00	SENSOR BRACKET	1	
29	2214-500001-00	SENSOR BRACKET	1	
30	2130-520009-00-01	LIFT PROXIMITY SWITCHES WIRING	1	Used for lift height 104"
30a	2130-520009-00-02	LIFT PROXIMITY SWITCHES WIRING	1	Used for lift height 126"
30b	2130-520009-00-03	LIFT PROXIMITY SWITCHES WIRING	1	Used for lift height 142"

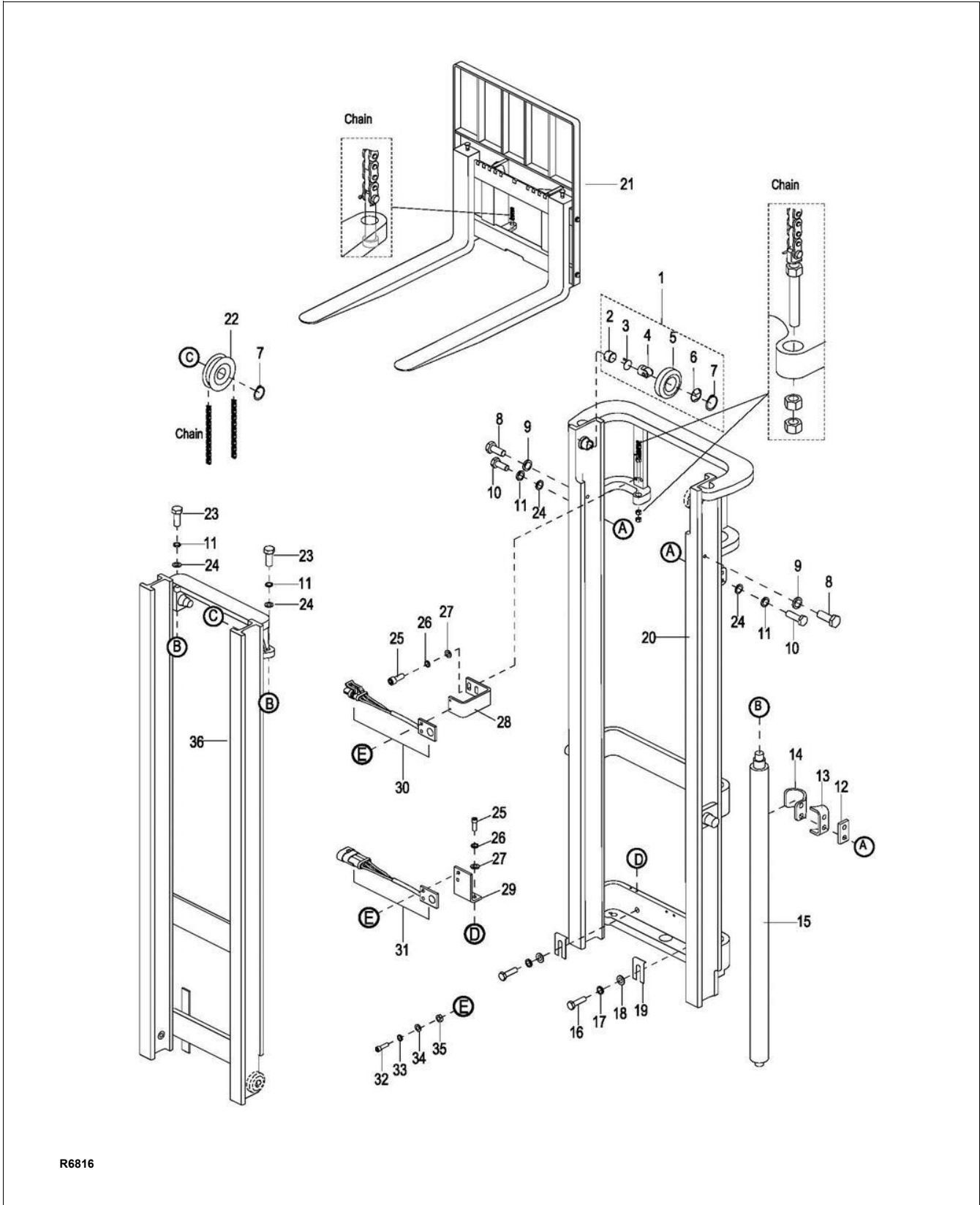

Figure 12-22 Elevation System (Telescopic) - Used up to Serial Number S2112138 - Continued

ELEVATION SYSTEM (TELESCOPIC) - USED UP TO SERIAL NUMBER S2112138 - CONTINUED

Pos.	Part Number	Description	Qty. Reqd.	Notes
31	2130-520003-00	PROXIMITY SWITCHES WIRING	1	
32	0000-000378-00	SCREW M4×16	4	
33	0000-000122-00	LOCK WASHER Ø4	4	
34	0000-000702-00	FLAT WASHER Ø4	4	
35	0000-000139-00	NUT M4	4	
36	2130-620000-00-01	INNER MAST	1	Used for lift height 104"
36a	2130-620000-00-02	INNER MAST	1	Used for lift height 126"
36b	2130-620000-00-03	INNER MAST	1	Used for lift height 142"

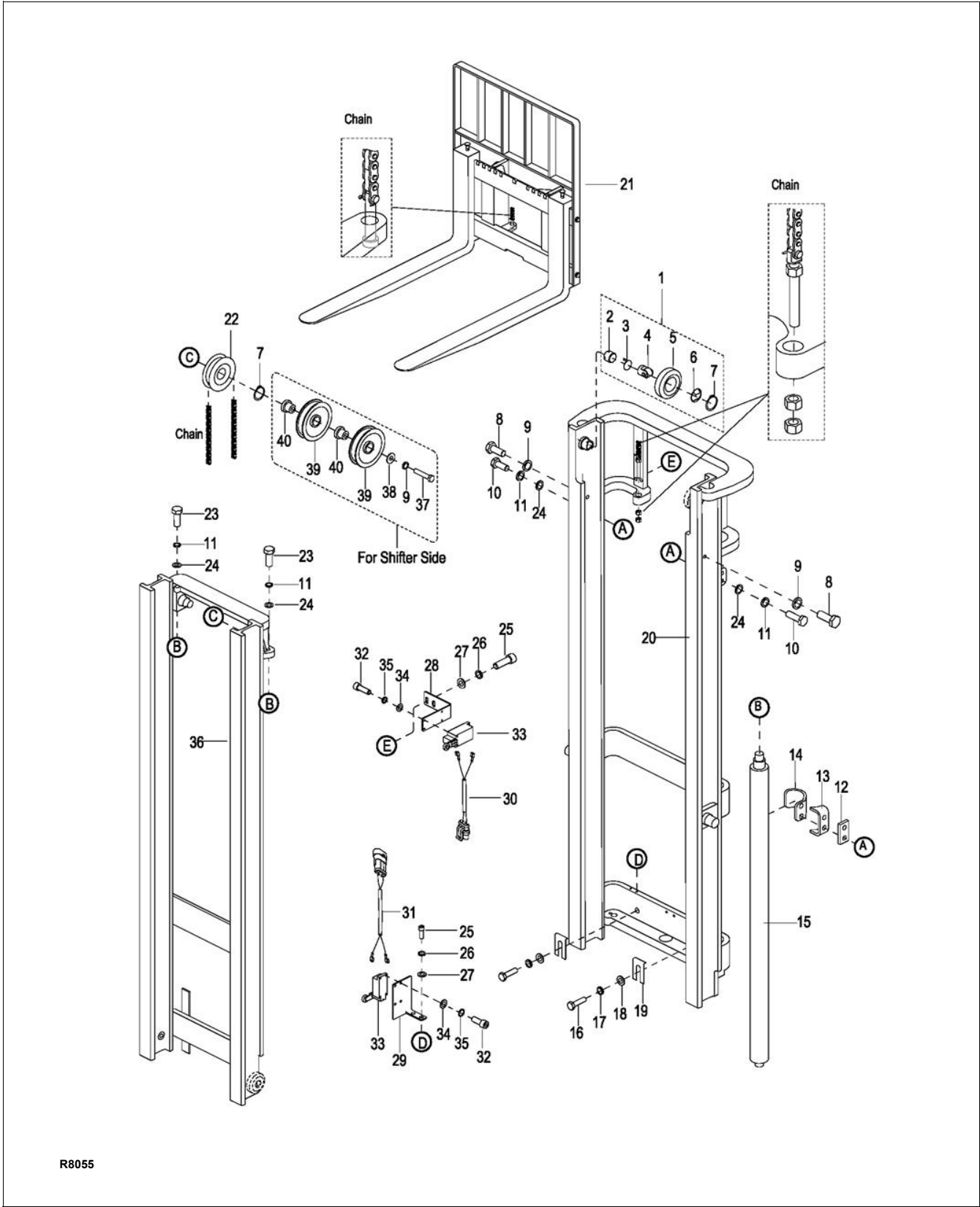

Figure 12-23 Elevation System (Telescopic) - Used from Serial Number S2112139

ELEVATION SYSTEM (TELESCOPIC) - USED FROM SERIAL NUMBER S2112139

Pos.	Part Number	Description	Qty. Reqd.	Notes
1	2125-612000-00	ROLLER ASSEMBLY	4	
2	2125-612004-00	SCREW	4	
3	2125-612007-00	SNAP RING	4	
4	2125-612002-00	ASSISTANT ROLLER	4	
5	2125-612001-00	MAIN ROLLER ASSEMBLY	4	
6	2125-612005-00	DUST SNAP	4	
7	0000-000183-00	RETAINER RING Ø35	6	
8	0000-000285-00	BOLT M12×35	2	
9	0000-000060-00	LOCK WASHER Ø12	3	
10	0000-000283-00	BOLT M10×35	4	
11	0000-000063-00	LOCK WASHER Ø10	6	
12	2214-600005-00	WASHER	A.R.	As Required
13	2214-600004-00	CYLINDER BRACKET	2	
14	2214-600003-00	CYLINDER CLIP	2	
15	2130-410000-00-01	LIFT CYLINDER	2	Used for lift height 104"
15a	2130-410000-00-02	LIFT CYLINDER	2	Used for lift height 126"
15b	2130-410000-00-03	LIFT CYLINDER	2	Used for lift height 142"
16	0000-000622-00	BOLT M16×40	2	
17	0000-000191-00	LOCK WASHER Ø16	2	
18	0000-000190-00	FLAT WASHER Ø16	2	
19	2214-600006-00	WASHER	A.R.	As Required
20	2130-610000-00-01	OUTER MAST	1	Used up to serial number 326170592 - for lift height 104"
20a	2130-610000-00-02	OUTER MAST	1	Used up to serial number 326170592 - for lift height 126"
20b	2130-610000-00-03	OUTER MAST	1	Used up to serial number 326170592 - for lift height 142"
20c	2130-610000-0B-01	OUTER MAST	1	Used from serial number 326170593 - for lift height 104"
20d	2130-610000-0B-02	OUTER MAST	1	Used from serial number 326170593 - for lift height 126"
20e	2130-610000-0B-03	OUTER MAST	1	Used from serial number 326170593 - for lift height 142"
20f	2130-610000-10-01	OUTER MAST	1	Used when SideShift - for lift height 104"
20g	2130-610000-10-02	OUTER MAST	1	Used when SideShift - for lift height 126"
20h	2130-610000-10-03	OUTER MAST	1	Used when SideShift - for lift height 142"

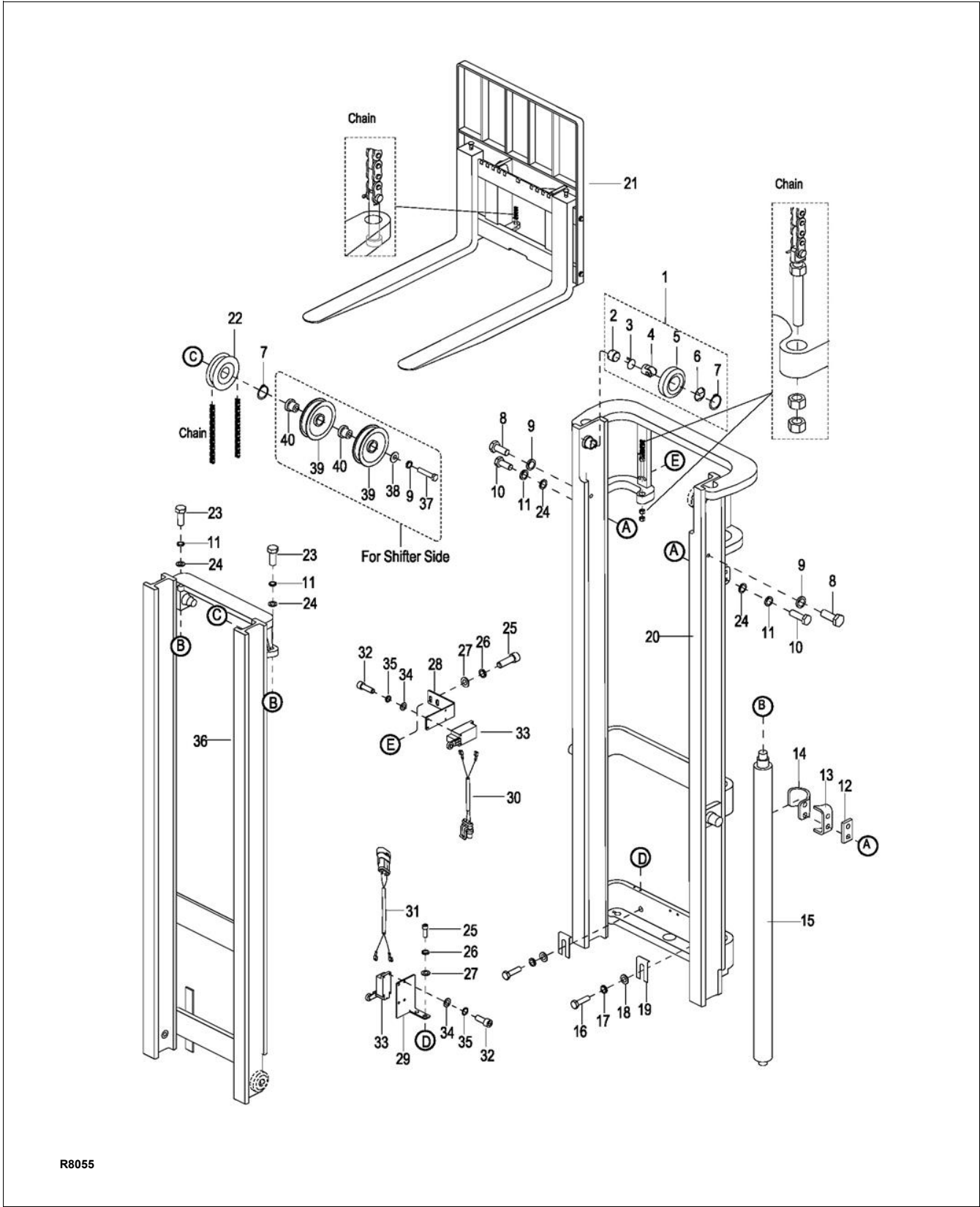

Figure 12-23 Elevation System (Telescopic) - Used from Serial Number S2112139 - Continued

ELEVATION SYSTEM (TELESCOPIC) - USED FROM SERIAL NUMBER S2112139 - CONTINUED

Pos.	Part Number	Description	Qty. Reqd.	Notes
21	SEE FORK CARRIAGE	FORK FRAME ASSEMBLY	1	See Telescopic Fork Carriage Section
21a	SEE FORK CARRIAGE	FORK FRAME ASSEMBLY	1	See Telescopic Fork Carriage Section (side shift)
22	2214-600001-00	CHAIN ROLLER	2	
23	0000-000244-00	BOLT M10×30	2	
24	0000-000071-00	FLAT WASHER Ø10	6	
25	0000-000109-00	SCREW M8×16	4	
26	0000-000159-00	LOCK WASHER Ø8	4	
27	0000-000176-00	FLAT WASHER Ø8	4	
28	2130-500002-0A	SENSOR BRACKET	1	
29	2130-500001-0A	SENSOR BRACKET	1	
30	2130-520009-27	PROXIMITY SWITCH WIRING	1	Used for lift height 104"
30a	2125-520009-29	PROXIMITY SWITCH WIRING	1	Used for lift height 126"
30b	2125-520009-31	PROXIMITY SWITCH WIRING	1	Used for lift height 142"
31	2130-520003-0A	PROXIMITY SWITCH WIRING	1	
32	0000-000004-00	SCREW M5×12	8	
33	2125-500003-00	PROXIMITY SWITCH 8108	2	
34	0000-000390-00	FLAT WASHER Ø5	8	
35	0000-000206-00	LOCK WASHER Ø5	8	
36	2130-620000-00-01	INNER MAST	1	Used for lift height 104"
36a	2130-620000-00-02	INNER MAST	1	Used for lift height 126"
36b	2130-620000-00-03	INNER MAST	1	Used for lift height 142"
36c	2130-620000-10-01	INNER MAST	1	Used when Side Shift - Used for lift height 104"
36d	2130-620000-10-02	INNER MAST	1	Used when Side Shift - Used for lift height 126"
36e	2130-620000-10-03	INNER MAST	1	Used when Side Shift - Used for lift height 142"
37	0000-000632-00	BOLT M12×80	1	Used when Side Shift
38	0000-000438-00	FLAT WASHER Ø12	1	Used when Side Shift
39	2125-600002-30	OIL PIPE ROLLER	2	Used when Side Shift
40	2125-600003-30	SLEEVE	2	Used when Side Shift

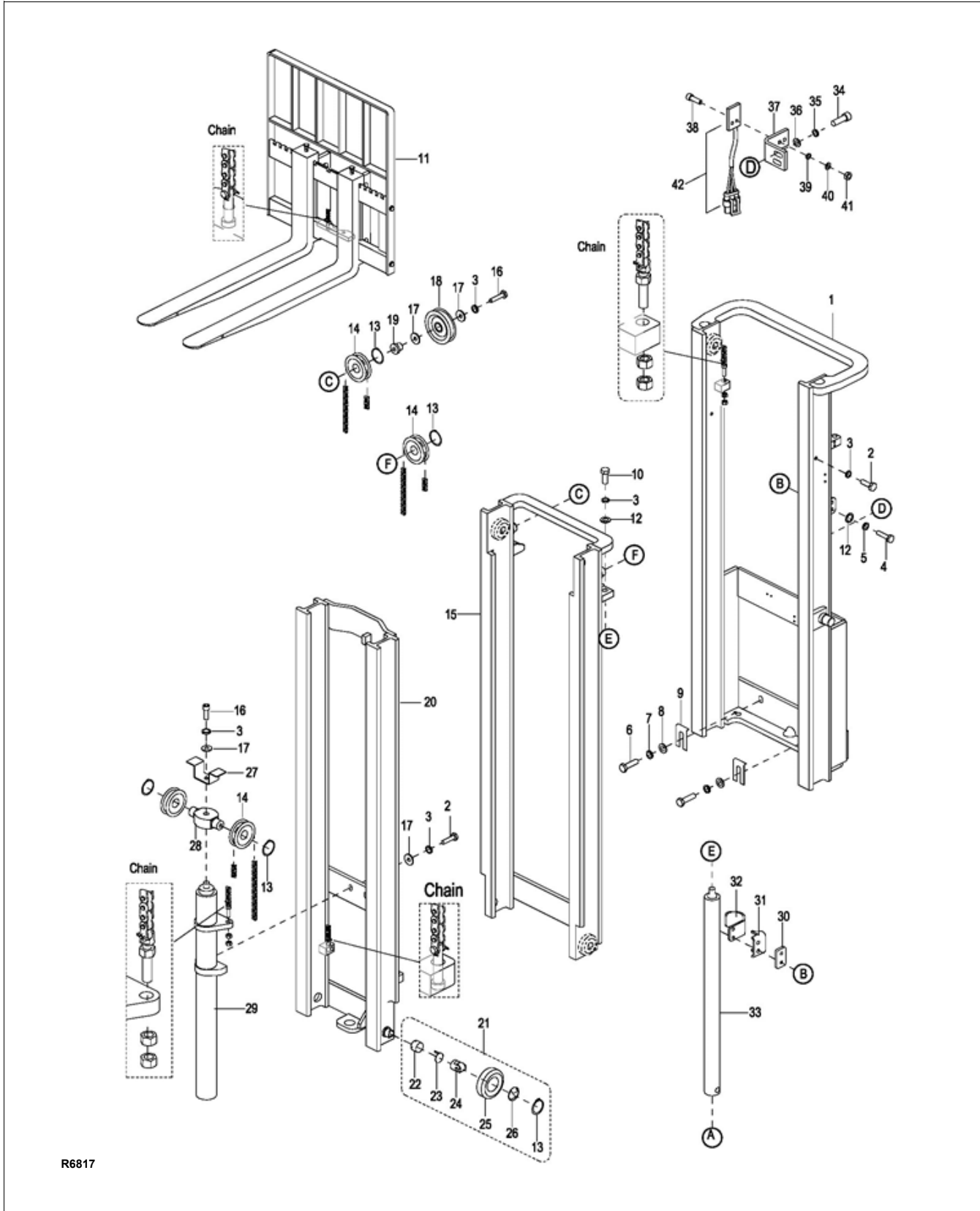
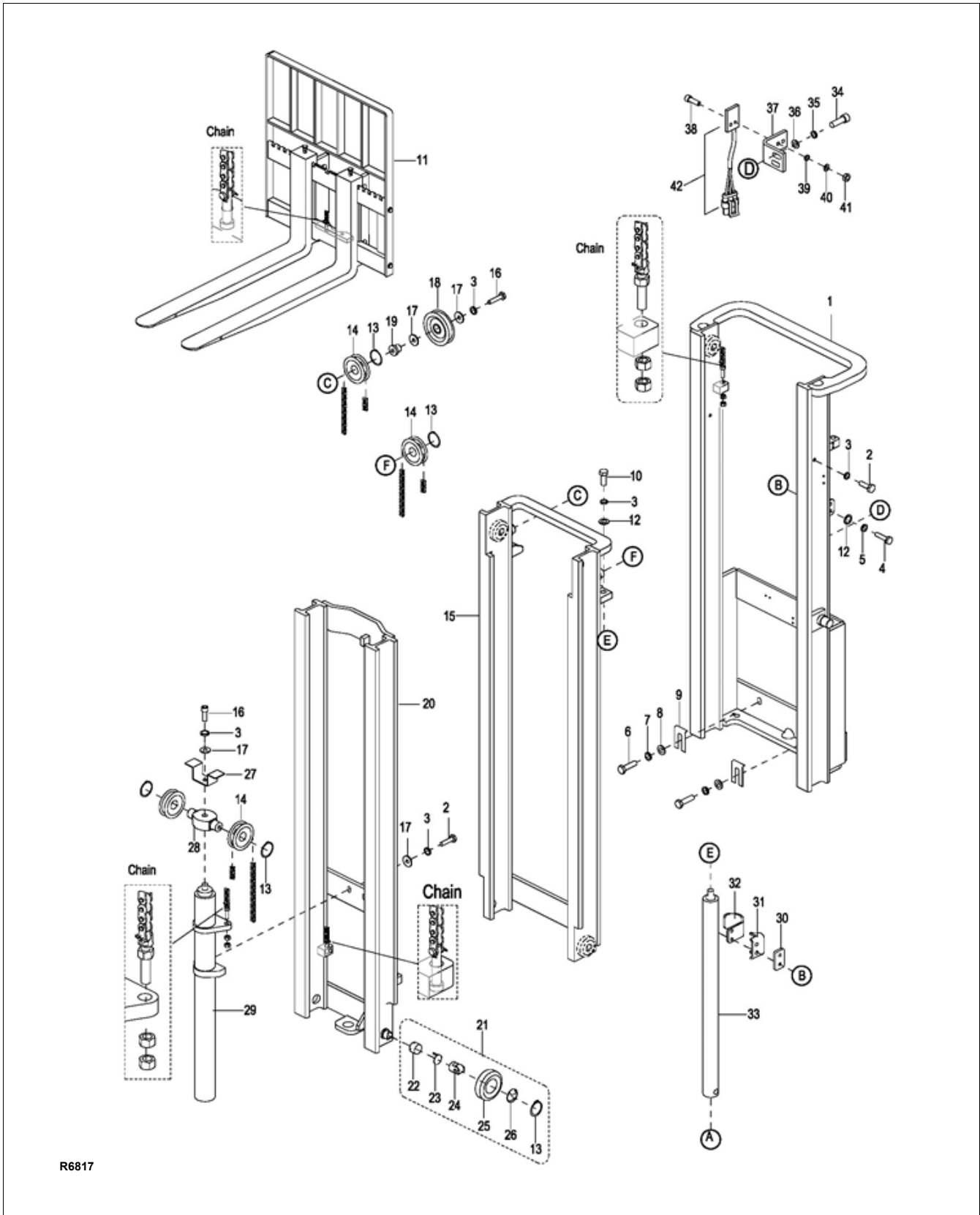

Figure 12-24 Elevation System (TRIMAST) - Used up to Serial Number S2112138

ELEVATION SYSTEM (TRIMAST) - USED UP TO SERIAL NUMBER S2112138

Pos.	Part Number	Description	Qty. Reqd.	Notes
1	2130-610000-30-01	OUTER MAST	1	Used for lift height 157"
1a	2130-610000-30-02	OUTER MAST	1	Used for lift height 177"
2	0000-000285-00	BOLT M12×30	2	
3	0000-000060-00	LOCKWASHER Ø12	4	
4	0000-000283-00	BOLT M10×35	4	
5	0000-000063-00	LOCKWASHER Ø10	6	
6	0000-000622-00	BOLT M16×40	2	
7	0000-000191-00	LOCKWASHER Ø16	2	
8	0000-000190-00	FLATWASHER Ø16	2	
9	2214-600006-00	WASHER	A.R.	As Required
10	0000-000244-00	BOLT M10×30	2	
11	SEE FORK CARRIAGE	FORK CARRIAGE ASSEMBLY	1	See TRIMAST Fork Carriage Section
12	0000-000071-00	FLATWASHER Ø10	6	
13	0000-000183-00	RETAINER RING Ø35	12	
14	2214-600001-00	CHAIN ROLLER	4	
15	2125-620000-30-01	MIDDLE MAST	1	Used for lift height 157"
15a	2125-620000-30-02	MIDDLE MAST	1	Used for lift height 177"
16	0000-000613-00	BOLT M12×50	1	
17	0000-000222-00	FLATWASHER Ø12	2	
18	2125-600002-30	HOSE REEL	1	
19	2125-600003-30	BUSHING	1	
20	2125-630000-30-01	INNER MAST	1	Used for lift height 157"
20a	2125-630000-30-02	INNER MAST	1	Used for lift height 177"
21	2125-612000-00	ROLLER ASSEMBLY	8	
22	2125-612004-00	SCREW	8	
23	2125-612007-00	SNAP RING	8	
24	2125-612002-00	SUPPORT ROLLER	8	
25	2125-612001-00	MAIN ROLLER ASSEMBLY	8	
26	2125-612005-00	DUST SNAP	8	
27	2125-600007-30	BRACKET	1	
28	2125-600001-30	ROLLER BRACKET	1	
29	2130-420000-30-01	FREE LIFT CYLINDER ASSEMBLY	1	Used for lift height 157"
29a	2130-420000-30-02	FREE LIFT CYLINDER ASSEMBLY	1	Used for lift height 177"
30	2214-600005-00	WASHER	A.R.	As Required
31	2125-600006-30	CYLINDER BRACKET	2	
32	2125-600005-30	CLIP	2	
33	2130-410000-30-01	LIFT CYLINDER ASSEMBLY	2	Used for lift height 157"
33a	2130-410000-30-02	LIFT CYLINDER ASSEMBLY	2	Used for lift height 177"



R6817

Figure 12-24 Elevation System (TRIMAST) - Used up to Serial Number S2112138 - Continued

ELEVATION SYSTEM (TRIMAST) - USED UP TO SERIAL NUMBER S2112138 - CONTINUED

Pos.	Part Number	Description	Qty. Reqd.	Notes
34	0000-000109-00	SCREW M8×16	2	
35	0000-000159-00	LOCKWASHER Ø8	2	
36	0000-000176-00	FLATWASHER Ø8	2	
37	2125-500002-30	SENSOR BRACKET	1	
38	0000-000378-00	SCREW M4×16	2	
39	0000-000122-00	LOCKWASHER Ø4	2	
40	0000-000702-00	FLATWASHER Ø4	2	
41	0000-000139-00	NUT M4	2	
42	2130-520009-30-01	LIFT PROXIMITY SWITCHES WIRING	1	Used for lift height 157"
42	2130-520009-30-02	LIFT PROXIMITY SWITCHES WIRING	1	Used for lift height 177"

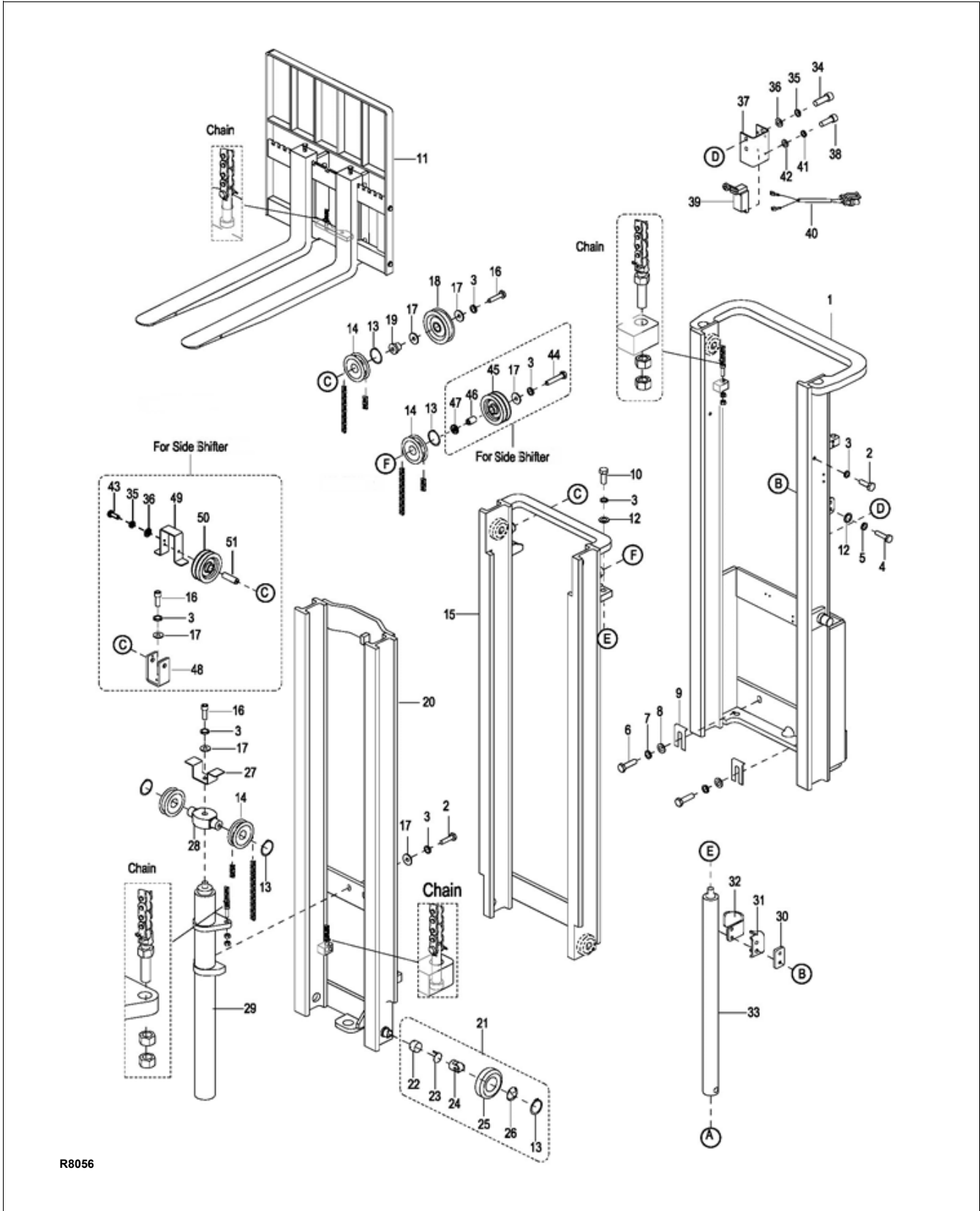

R8056

Figure 12-25 Elevation System (TRIMAST) - Used from Serial Number S2112139
And Trucks with Side Shift

**ELEVATION SYSTEM (TRIMAST) - USED FROM SERIAL NUMBER S2112139
And Trucks with Side Shift)**

Pos.	Part Number	Description	Qty. Reqd.	Notes
1	2130-610000-30-01	OUTER MAST	1	Used up to serial number 326170592 - for lift height 157"
1a	2130-610000-30-02	OUTER MAST	1	Used up to serial number 326170592 - for lift height 177"
1b	2130-610000-3C-01	OUTER MAST	1	Used from serial number 326170593 - for lift height 157"
1c	2130-610000-3C-02	OUTER MAST	1	Used from serial number 326170593 - for lift height 177"
1d	2130-610000-40-01	OUTER MAST	1	Used when side shift for lift height 157"
1e	2130-610000-40-02	OUTER MAST	1	Used when side shift for lift height 177"
2	0000-000285-00	BOLT M12×30	2	
3	0000-000060-00	LOCKWASHER Ø12	5	
4	0000-000283-00	BOLT M10×35	4	
5	0000-000063-00	LOCKWASHER Ø10	6	
6	0000-000622-00	BOLT M16×40	2	
7	0000-000191-00	LOCKWASHER Ø16	2	
8	0000-000190-00	FLATWASHER Ø16	2	
9	2214-600006-00	WASHER	Req.	
10	0000-000244-00	BOLT M10×30	2	
11	SEE FORK CARRIAGE	FORK CARRIAGE ASSEMBLY	1	See TRIMAST Fork Carriage Section
11a	SEE FORK CARRIAGE	FORK CARRIAGE ASSEMBLY	1	See TRIMAST Fork Carriage Section
12	0000-000071-00	FLATWASHER Ø10	6	
13	0000-000183-00	RETAINER RING Ø35	12	
14	2214-600001-00	CHAIN ROLLER	4	
15	2125-620000-30-01	MIDDLE MAST	1	Used for lift height 157"
15a	2125-620000-30-02	MIDDLE MAST	1	Used for lift height 177"
15b	2125-620000-40-01	MIDDLE MAST	1	Used when side shift for lift height 157"
15c	2125-620000-40-02	MIDDLE MAST	1	Used when side shift for lift height 177"
16	0000-000613-00	BOLT M12×50	2	
17	0000-000222-00	FLATWASHER Ø12	2	
18	2125-600002-30	OIL PIPE ROLLER	1	
19	2125-600003-30	SLEEVE	1	
20	2125-630000-30-01	INNER MAST	1	Used for lift height 157"
20a	2125-630000-30-02	INNER MAST	1	Used for lift height 177"
20b	2125-630000-40-01	INNER MAST	1	Used when side shift for lift height 157"
20c	2125-630000-40-02	INNER MAST	1	Used when side shift for lift height 177"

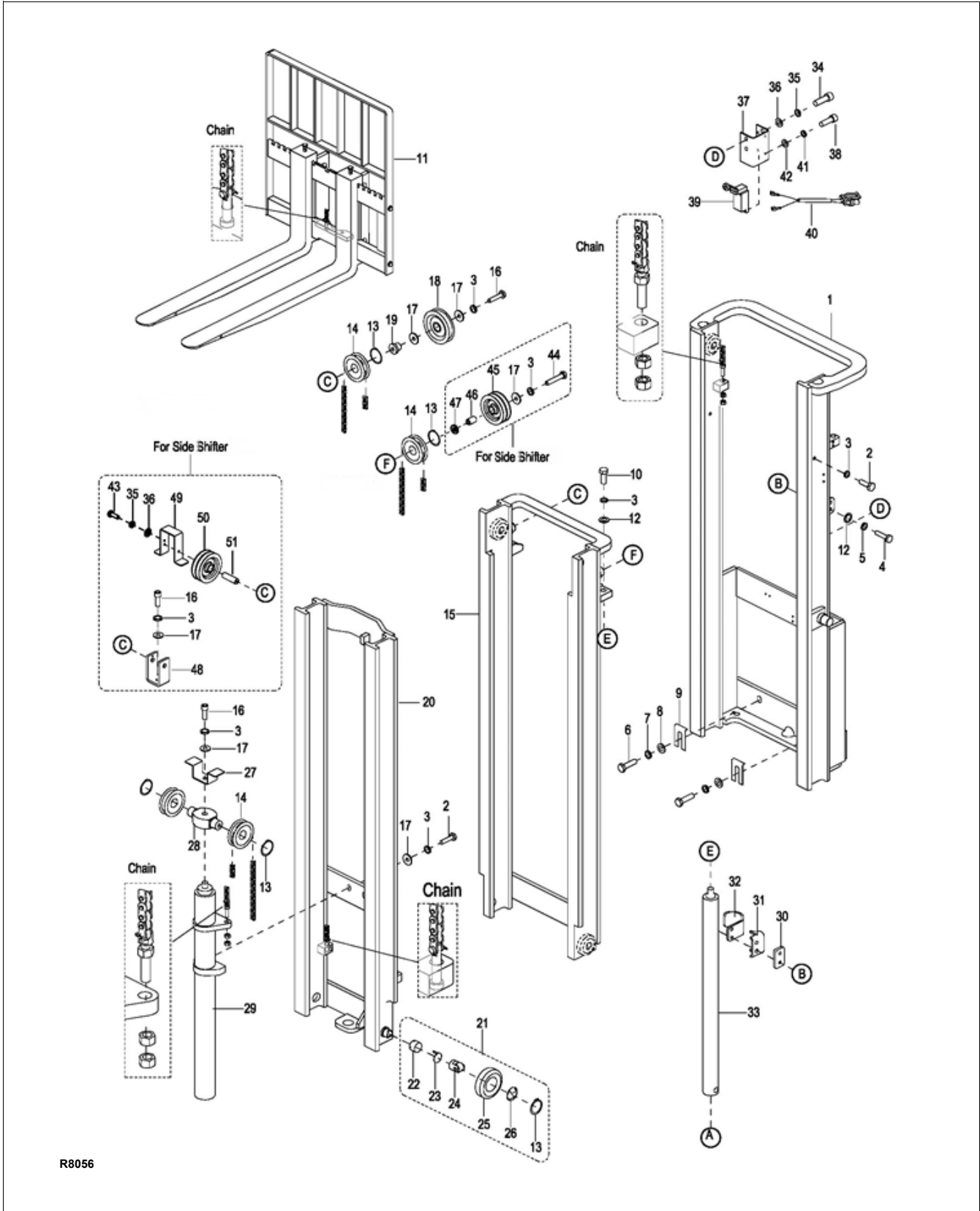

R8056

Figure 12-26 Elevation System (TRIMAST) - Used from S/N S2112139
And Trucks with Side Shift - Continued

**ELEVATION SYSTEM (TRIMAST) - USED FROM S/N S2112139)
And Trucks with Side Shift) - CONTINUED**

Pos.	Part Number	Description	Qty. Reqd.	Notes
21	2125-612000-00	ROLLER ASSEMBLY	8	
22	2125-612004-00	SCREW	8	
23	2125-612007-00	SNAP RING	8	
24	2125-612002-00	SUPPORT ROLLER	8	
25	2125-612001-00	MAIN ROLLER ASSEMBLY	8	
26	2125-612005-00	DUST SNAP	8	
27	2125-600007-30	BRACKET	1	
28	2125-600001-30	ROLLER BRACKET	1	
29	2130-420000-30-01	FREE LIFT CYLINDER ASSEMBLY	1	Used for lift height 157"
29a	2130-420000-30-02	FREE LIFT CYLINDER ASSEMBLY	1	Used for lift height 177"
30	2214-600005-00	WASHER	Req.	
31	2125-600006-30	CYLINDER BRACKET	2	
32	2125-600005-30	CLIP	2	
33	2130-410000-30-01	LIFT CYLINDER ASSEMBLY	2	Used for lift height 157"
33a	2130-410000-30-02	LIFT CYLINDER ASSEMBLY	2	Used for lift height 177"
34	0000-000109-00	SCREW M8×16	2	
35	0000-000159-00	LOCKWASHER Ø8	2	
36	0000-000176-00	FLATWASHER Ø8	2	
37	2125-500002-3A	SENSOR BRACKET	1	
38	0000-000004-00	SCREW M5×12	4	
39	2125-500002-00	PROXIMITY SWITCH	1	Used for lift height 157"
39a	2125-500003-00	PROXIMITY SWITCH	1	Used for lift height 177"
40	2125-520009-24	PROXIMITY SWITCH WIRING	1	Used for lift height 157"
40a	2125-520009-26	PROXIMITY SWITCH WIRING	1	Used for lift height 177"
41	0000-000206-00	LOCKWASHER Ø5	4	
42	0000-000390-00	FLATWASHER Ø5	4	
43	0000-000242-00	BLOT M8×16	3	Used when Side Shift option on truck
44	0000-000919-00	BOLT M12×65	1	Used when Side Shift option on truck
45	K25S100007-Y	DOUBLE TUBE ROUND	1	Used when Side Shift option on truck
46	3215-800002-30	TUBE AXLE	1	Used when Side Shift option on truck
47	3215-800001-30	PLATE	1	Used when Side Shift option on truck
48	3215-800004-30	FIXED PLATE	1	Used when Side Shift option on truck
49	3215-800005-30	BRACKET	1	Used when Side Shift option on truck
50	3215-800006-30	MIDDLE TUBE ROUND	1	Used when Side Shift option on truck
51	3215-800003-30	TUBE AXLE	1	Used when Side Shift option on truck

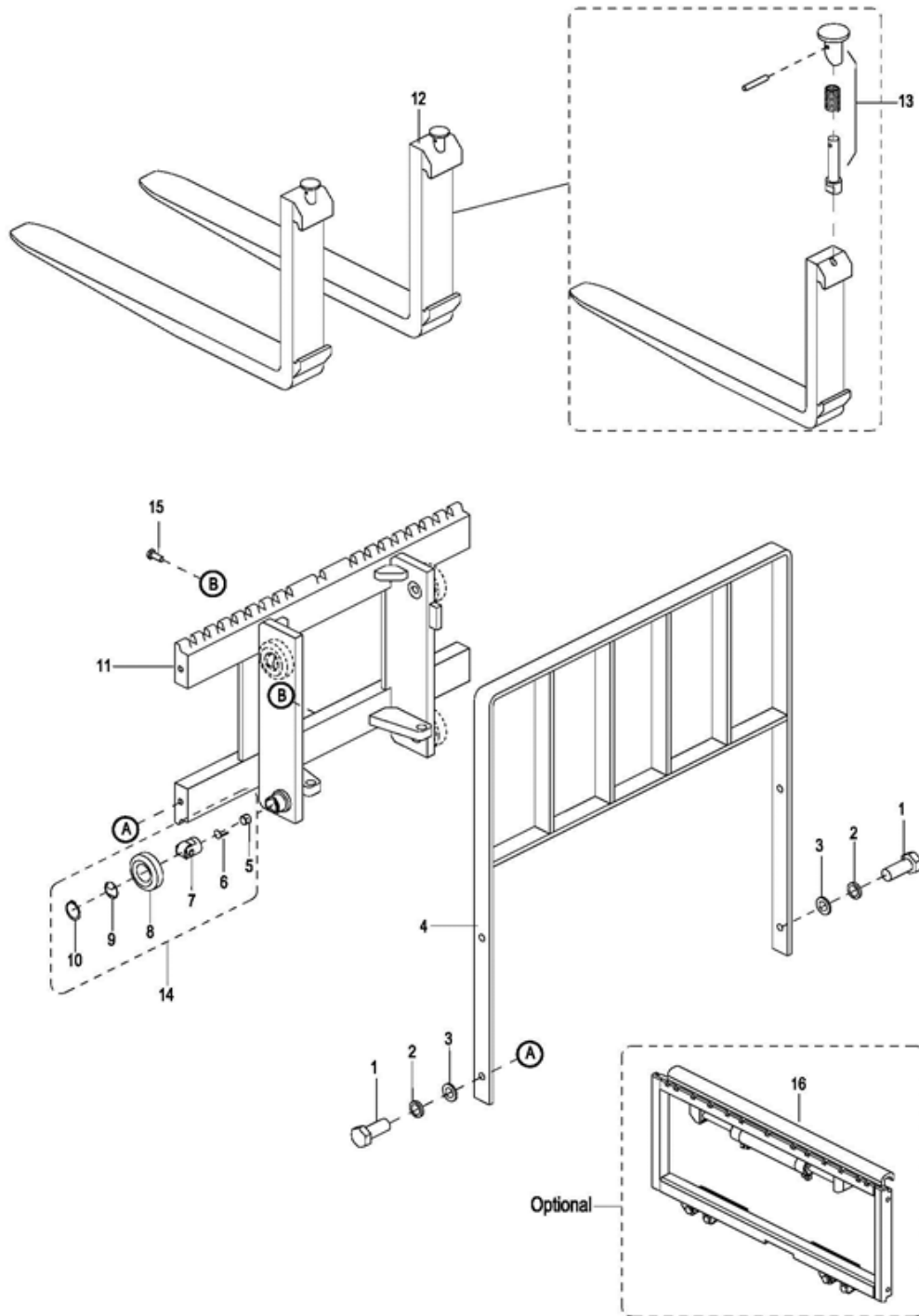

R6815

Figure 12-27 Fork Carriage - Telescopic

FORK CARRIAGE - TELESCOPIC

Pos.	Part Number	Description	Qty. Reqd.	Notes
1	0000-000221-00	BOLT M12×30	4	
2	0000-000060-00	LOCKWASHER Ø12	4	
3	0000-000373-00	FLATWASHER Ø12	4	
4	2125-632000-00	LOAD BACKREST	1	36" Load Backrest
4a	2125-632000-10	LOAD BACKREST	1	48" Load Backrest
5	2125-631104-00	SCREW	4	
6	2125-612007-00	SNAP RING	4	
7	2125-612002-00	SUPPORT ROLLER	4	
8	2125-612001-00	MAIN ROLLER ASSEMBLY	4	
9	2125-612005-00	DUST SNAP	4	
10	0000-000183-00	RETAINER RING Ø35	4	
11	2130-631000-00	FORK CARRIAGE	1	
11a	2130-631000-10	FORK CARRIAGE	1	Used when Side Shift Option
12	2125-630001-00-01	FORK	2	Fork Length: 42" (1070mm)
13	2125-630001-10	PIN ASSEMBLY	2	
14	2125-631100-00	ROLLER ASSEMBLY	1	
15	0000-000030-00	SCREW M10×16	1	
16	2130-641000-40	SIDE SHIFT ATTACHMENT	1	Optional

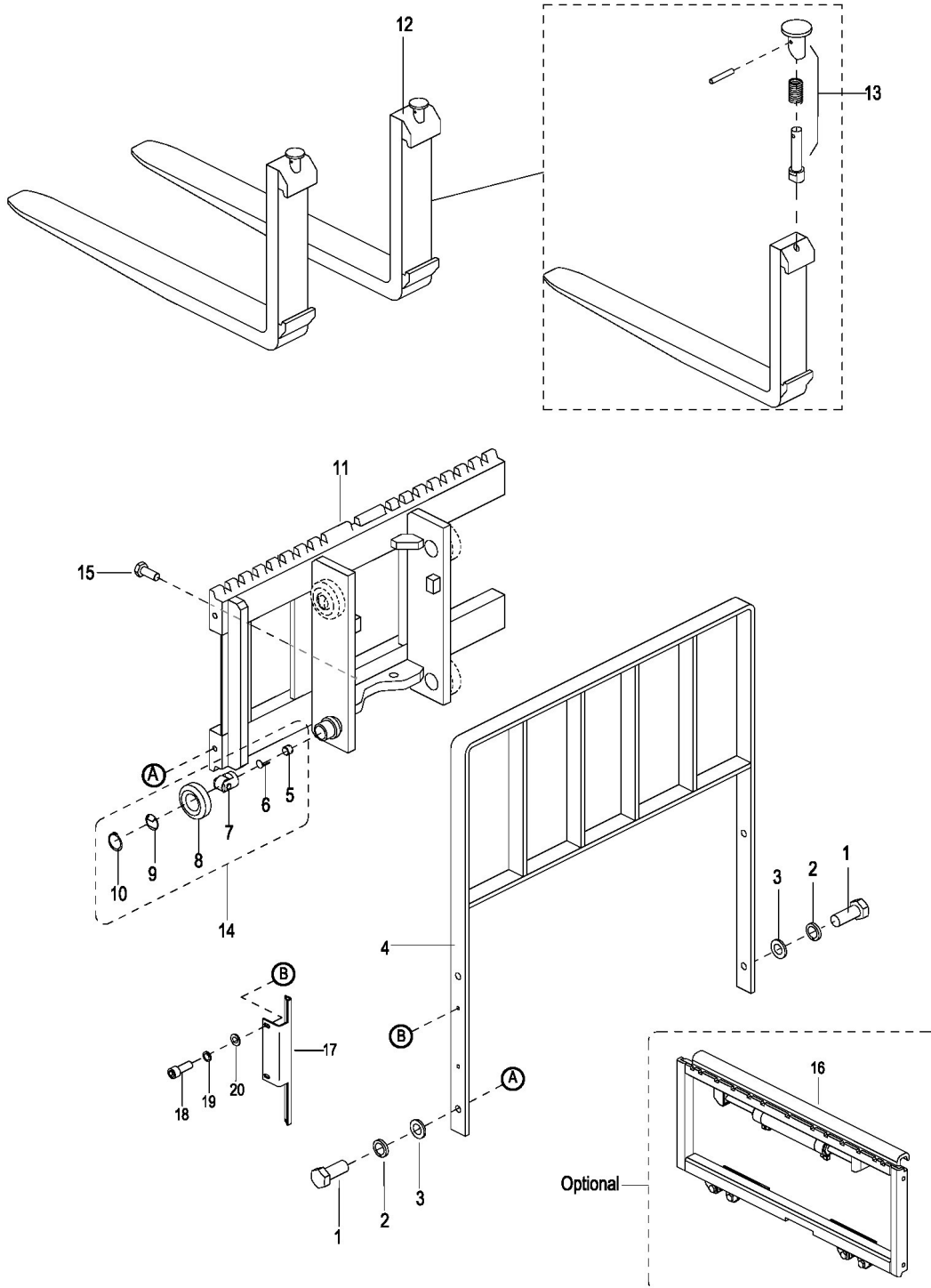

R8057

Figure 12-28 Fork Carriage - Trimast

FORK CARRIAGE - TRIMAST

Pos.	Part Number	Description	Qty. Reqd.	Notes
1	0000-000221-00	BOLT M12×30	4	
2	0000-000060-00	LOCKWASHER Ø12	4	
3	0000-000373-00	FLATWASHER Ø12	4	
4	2125-632000-00	LOAD BACKREST	1	36" Load Backrest - Used up to serial number 324170029
4a	2125-632000-0A	LOAD BACKREST	1	36" Load Backrest - Used from serial number 324170030
4b	2125-632000-10	LOAD BACKREST	1	48" Load Backrest - Used up to serial number 324170029
4c	2125-632000-1A	LOAD BACKREST	1	48" Load Backrest - Used from serial number 324170030
5	2125-631104-00	SCREW	4	
6	2125-612007-00	SNAP RING	4	
7	2125-612002-00	SUPPORT ROLLER	4	
8	2125-612001-00	MAIN ROLLER ASSEMBLY	4	
9	2125-612005-00	DUST SNAP	4	
10	0000-000183-00	RETAINER RING Ø35	4	
11	2125-641000-30	FORK CARRIAGE	1	Used up to serial number 324200418
11a	2130-641000-30	FORK CARRIAGE	1	With bracket mount for speed reduction switch - Used from serial number 324200419
12	2125-630001-00-01	FORK	2	Fork Length: 42" (1070mm)
13	2125-630001-10	PIN ASSEMBLY	2	
14	2125-631100-00	ROLLER ASSEMBLY	4	
15	0000-000030-00	SCREW M10×16	1	
16	2130-641000-40	SIDE SHIFT ATTACHMENT	1	Optional
17	2130-642000-30	PLATE	1	Used between serial number 324170030 and 324200418
18	0000-000109-00	SCREW M8×16	2	Used between serial number 324170030 and 324200418
19	0000-000159-00	LOCKWASHER Ø8	2	Used between serial number 324170030 and 324200418
20	0000-000176-00	FLATWASHER Ø8	2	Used between serial number 324170030 and 324200418

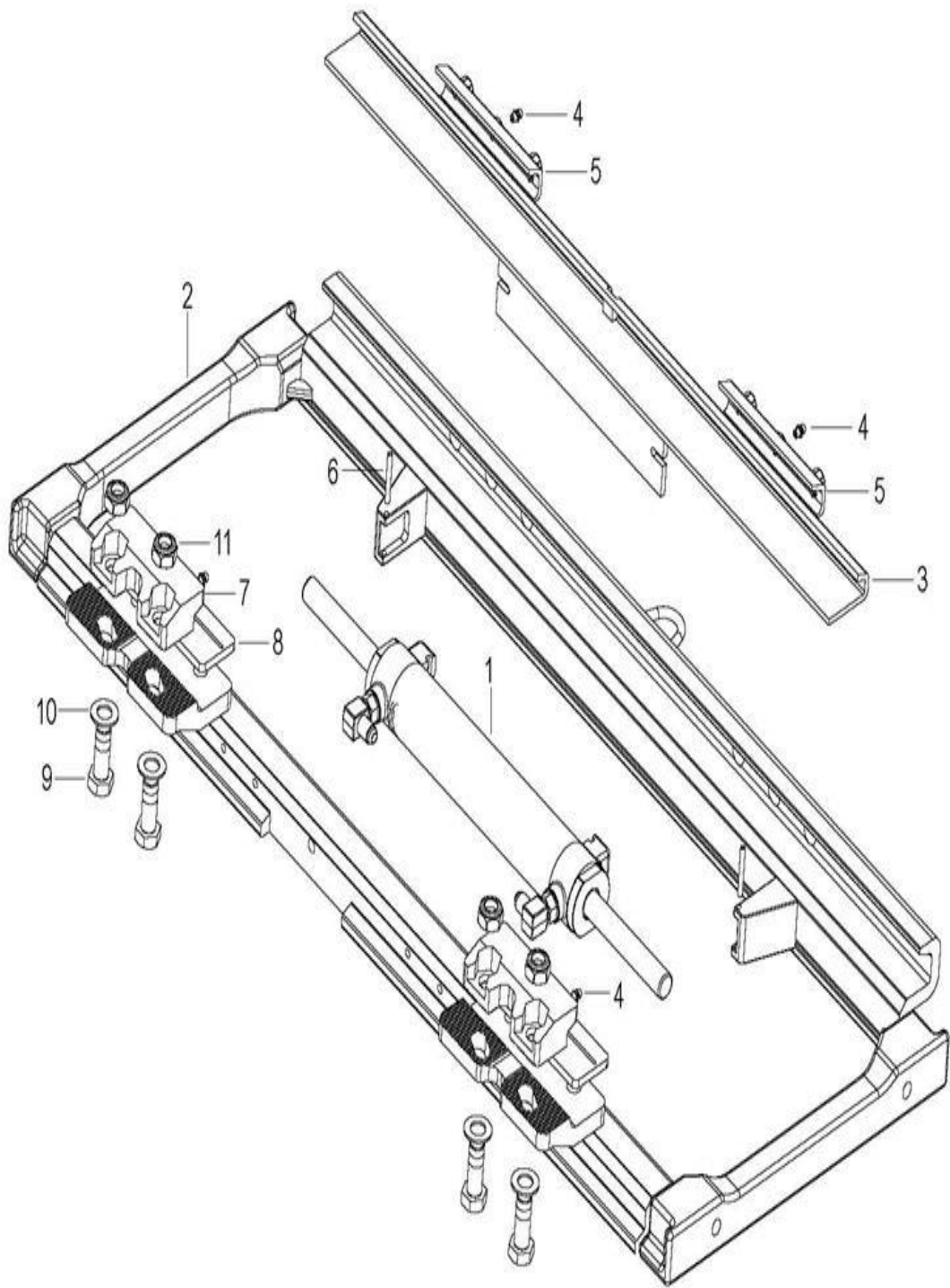

R8073

Figure 12-29 Side Shift Assembly

SIDE SHIFT ASSEMBLY

Pos.	Part Number	Description	Qty. Reqd.	Notes
--	2130-641000-40	SIDE SHIFT ASSEMBLY	1	
1	2130-641001-40	CYLINDER ASSEMBLY	1	
2	2130-641100-40	SIDE SHIFT CARRIAGE	1	
3	2130-641002-40	SIDE SHIFT PLATE	1	
4	0000-000587-00	LUBRICATION FITTING M6	4	
5	2130-641003-40	SIDE SHIFT PLATE, UPPER	2	
6	0000-001425-00	ROLL PIN M5 X 40	2	
7	2130-641004-40	LOCKING BLOCK	2	
8	2130-641005-40	LOWER SLIDE PLATE	2	
9	0000-000996-00	BOLT M16×45	4	
10	0000-000220-00	WASHER	4	
11	0000-001261-00	NUT	4	
12	2130-ZWCYG-0A	SEAL KIT OF CYLINDER	1	
13	2130-ZWHK-0A	PLASTIC SLIDE PLATE	1	

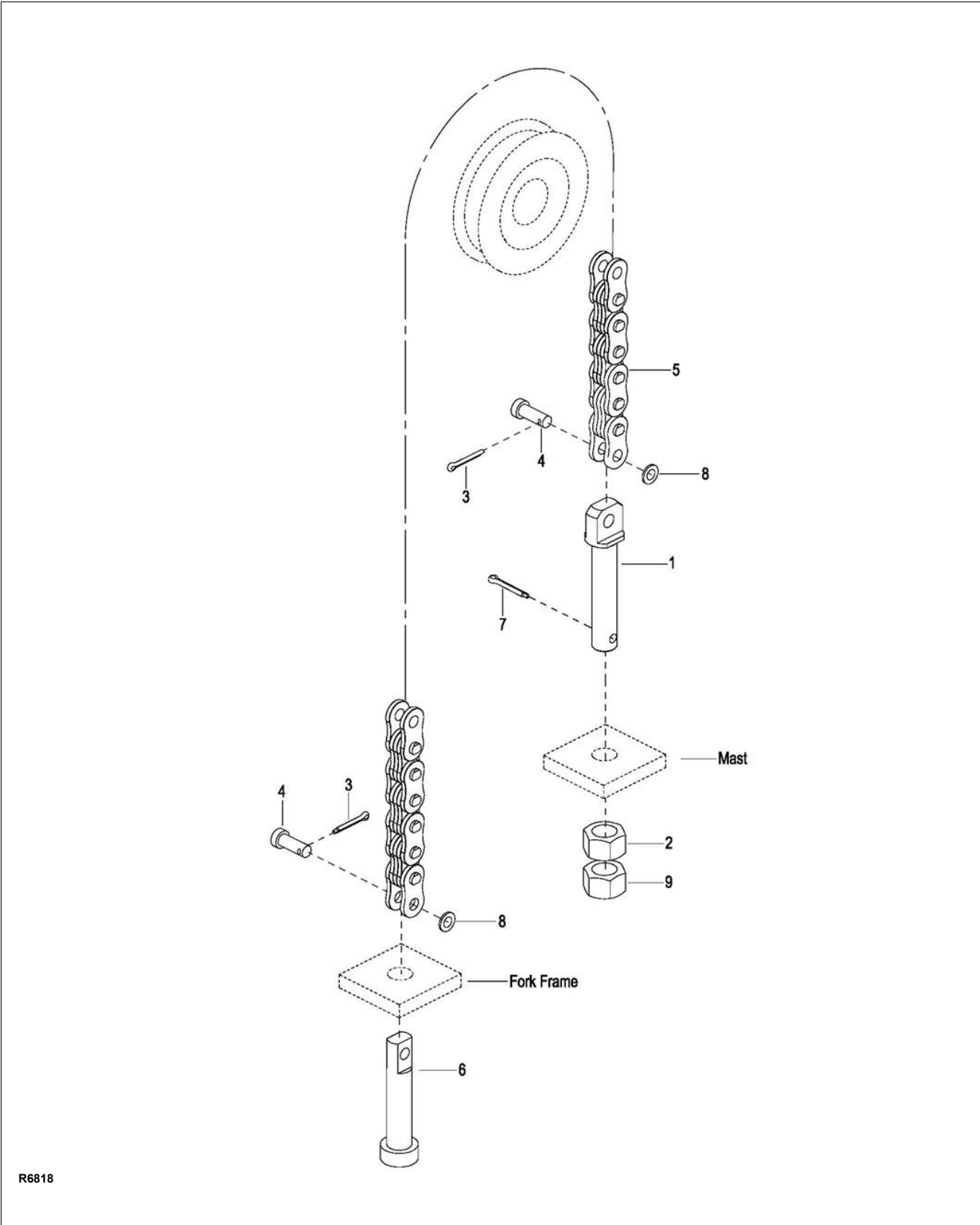

R6818

Figure 12-30 Chain Assembly

CHAIN ASSEMBLY

Pos.	Part Number	Description	Qty. Reqd.	Notes
1	2125-640001-00	BOLT	1	
2	0000-000187-00	NUT M16×1.5	1	
3	0000-000188-00	COTTER PIN Ø3.2×20	2	
4	2125-640002-00	PIN	2	
5	2125-640000-00-02	CHAIN ASSEMBLY	1	Used for lift height 104" - Telescopic
5	2125-640000-00-04	CHAIN ASSEMBLY	1	Used for lift height 126" - Telescopic
5	2125-640000-00-06	CHAIN ASSEMBLY	1	Used for lift height 142" - Telescopic
5	2125-651000-30-01	CHAIN ASSEMBLY - CHAIN I (FREELIFT)	1	Used for lift height 157" - TRIMAST
5	2125-652000-30-01	CHAIN ASSEMBLY - CHAIN II (SECONDARY)	1	Used for lift height 157" - TRIMAST
5	2125-651000-30-02	CHAIN ASSEMBLY - CHAIN I (FREELIFT)	1	Used for lift height 177" - TRIMAST
5	2125-652000-30-02	CHAIN ASSEMBLY - CHAIN II (SECONDARY)	1	Used for lift height 177" - TRIMAST
6	2125-640003-00	CHAIN ANCHOR	1	
7	0000-000686-00	COTTER PIN Ø3.2×32	1	
8	0000-000176-00	FLATWASHER Ø8	2	
9	3030-250000-01	NUT M16×1.5	1	

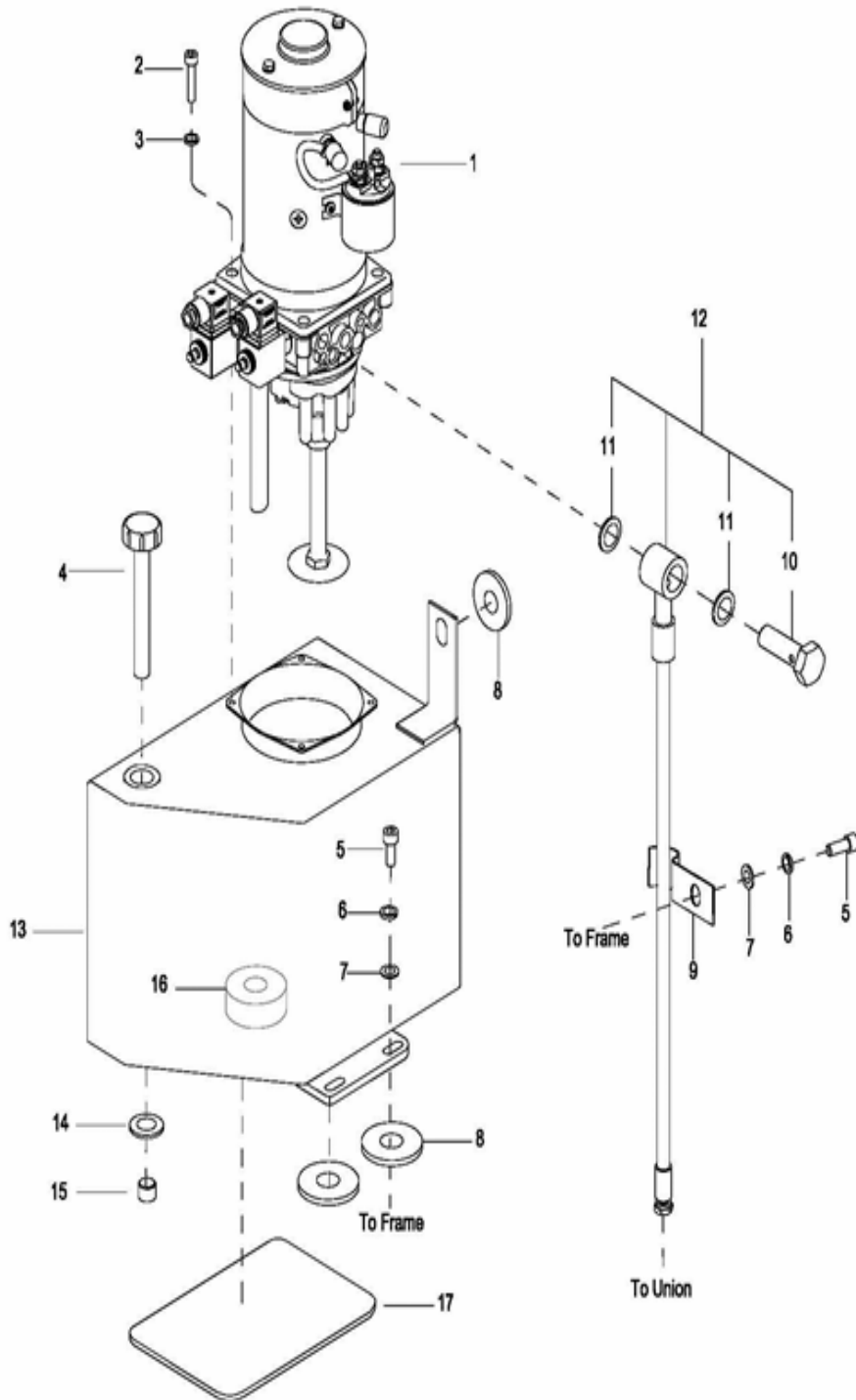

R6819

Figure 12-31 Hydraulic System (Not used when Side Shift Option)

HYDRAULIC SYSTEM (NOT USED WHEN SIDE SHIFT OPTION)

Pos.	Part Number	Description	Qty. Reqd.	Notes
1	2130-430000-00	PUMP & MOTOR ASSEMBLY	1	Please check part numbers on Assembly. Used up to serial number S2117012.
1a	2130-430000-0A	PUMP & MOTOR ASSEMBLY	1	Please check part numbers on Assembly. Used between serial number S2117012 - 326170592.
1b	2214-413000-00	PUMP & MOTOR ASSEMBLY	1	Please check part numbers on Assembly. Used between serial number S2117012 - 326170592.
1c	2218-421000-00	PUMP & MOTOR ASSEMBLY	1	Please check part numbers on Assembly. Used between serial number 326170593 - 3281901818
1d	2218-421000-P0	PUMP & MOTOR ASSEMBLY	1	Please check part numbers on Assembly. Used from serial number 3281901819
2	0000-000710-00	SCREW M6×45	4	
3	0000-000056-00	LOCKWASHER Ø6	4	
4	2130-423000-00	FILTER	1	
5	0000-000109-00	SCREW M8×16	4	
6	0000-000159-00	LOCKWASHER Ø8	4	
7	0000-000176-00	FLATWASHER Ø8	4	
8	2112-410004-00	WASHER	3	
9	2112-400002-00	HOSE CLAMP	1	
10	2402-143500-00	CONNECTOR BOLT G1/4×35	1	For PDS30
11	0000-000044-00	WASHER Ø14	4	
12	2130-460000-00	HOSE	1	For PDS30
12a	2140-410000-00	HOSE	1	For PDS40
13	2130-421000-00	TANK	1	
14	0000-000510-00	WASHER Ø20	1	
15	0000-000635-00	PLUG M18×1.5	1	
16	2125-420001-00	MAGNET	1	
17	2112-410005-00	RUBBER CUSHION	1	

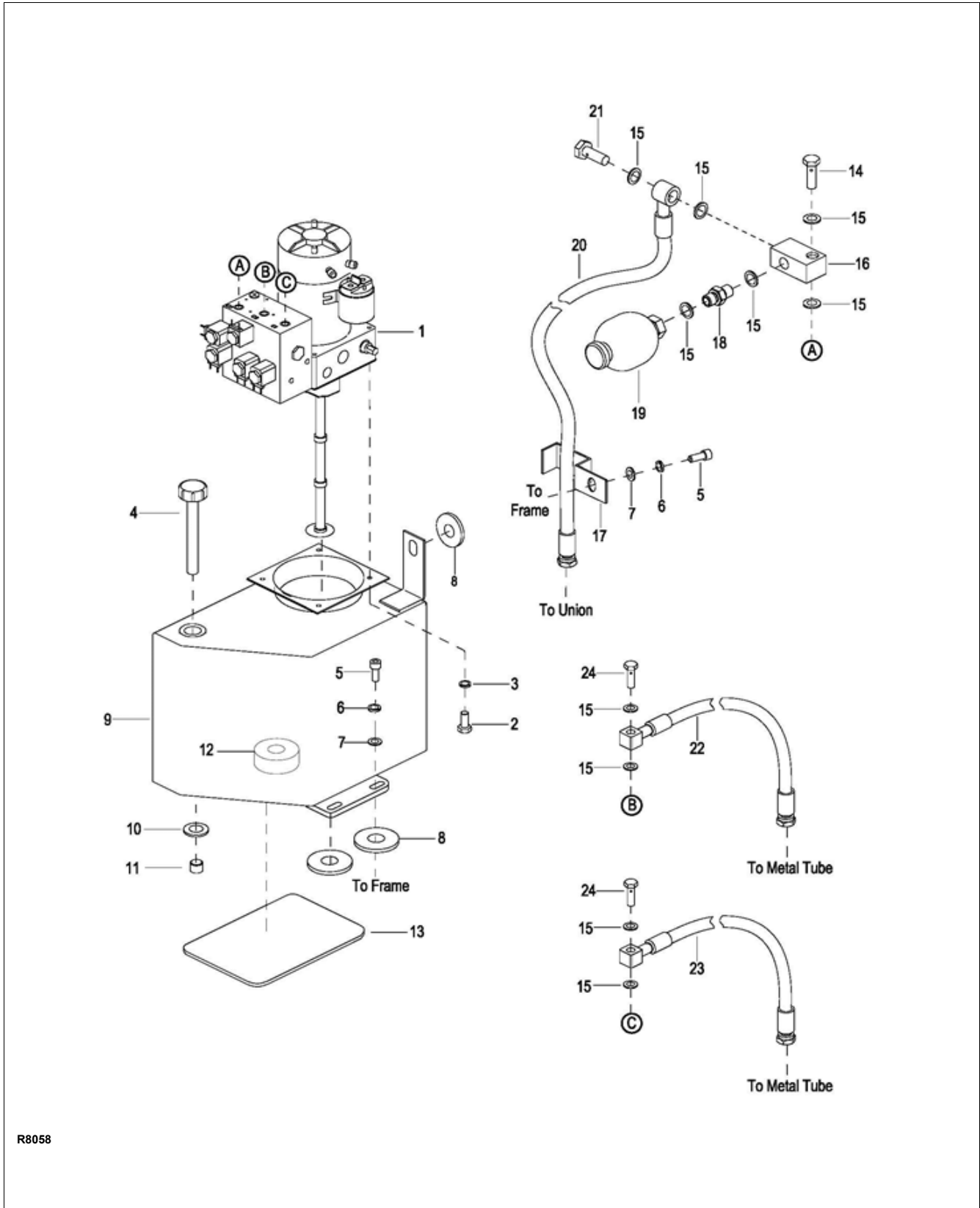

R8058

Figure 12-32 Hydraulic System (Used when Side Shift Option)

HYDRAULIC SYSTEM (USED WHEN SIDE SHIFT OPTION)

Pos.	Part Number	Description	Qty. Reqd.	Notes
1	2130-470000-40	PUMP & MOTOR ASSEMBLY	1	
2	0000-000620-00	BOLT M 6×16	4	
3	0000-000056-00	LOCKWASHER Ø6	4	
4	2130-423000-00	FILTER	1	
5	0000-000109-00	SCREW M8×16	5	
6	0000-000159-00	LOCKWASHER Ø8	5	
7	0000-000176-00	FLATWASHER Ø8	5	
8	2112-410004-00	WASHER	3	
9	2130-421000-40	TANK	1	
10	0000-000510-00	WASHER Ø20	1	
11	0000-000635-00	PLUG M18×1.5	1	
12	2125-420001-00	MAGNET	1	
13	2112-410005-00	RUBBER CUSHION	1	
14	2402-144000-00	BOLT G1/4×40	1	
15	0000-000044-00	WASHER Ø14	10	
16	2214-420001-0B	BLOCK CROSS	1	
17	2130-400001-40	HOSE CLAMP	1	
18	2701-141400-00	CONNECTOR M14X1.5-M14X1.5	1	
19	2214-423000-00	ACCUMULATOR	1	
20	2130-460000-00	HOSE	1	
21	2402-143500-00	BOLT G1/4×35	1	
22	2130-410000-10	OIL PIPE I	1	Used on Telescopic Mast PDS30
22a	2130-410000-40	OIL PIPE I	1	Used on TRIMAST Mast PDS30
22b	2140-410000-10	OIL PIPE I	1	Used on Telescopic Mast PDS40
22c	2140-410000-40	OIL PIPE I	1	Used on TRIMAST Mast PDS40
23	2130-420000-10	OIL PIPE II	1	Used on Telescopic Mast PDS30
23a	2130-460000-40	OIL PIPE II	1	Used on TRIMAST Mast PDS30
23b	2140-420000-10	OIL PIPE II	1	Used on Telescopic Mast PDS40
23c	2140-460000-40	OIL PIPE II	1	Used on TRIMAST Mast PDS40
24	2402-143700-A0	BOLT G1/4×37	2	

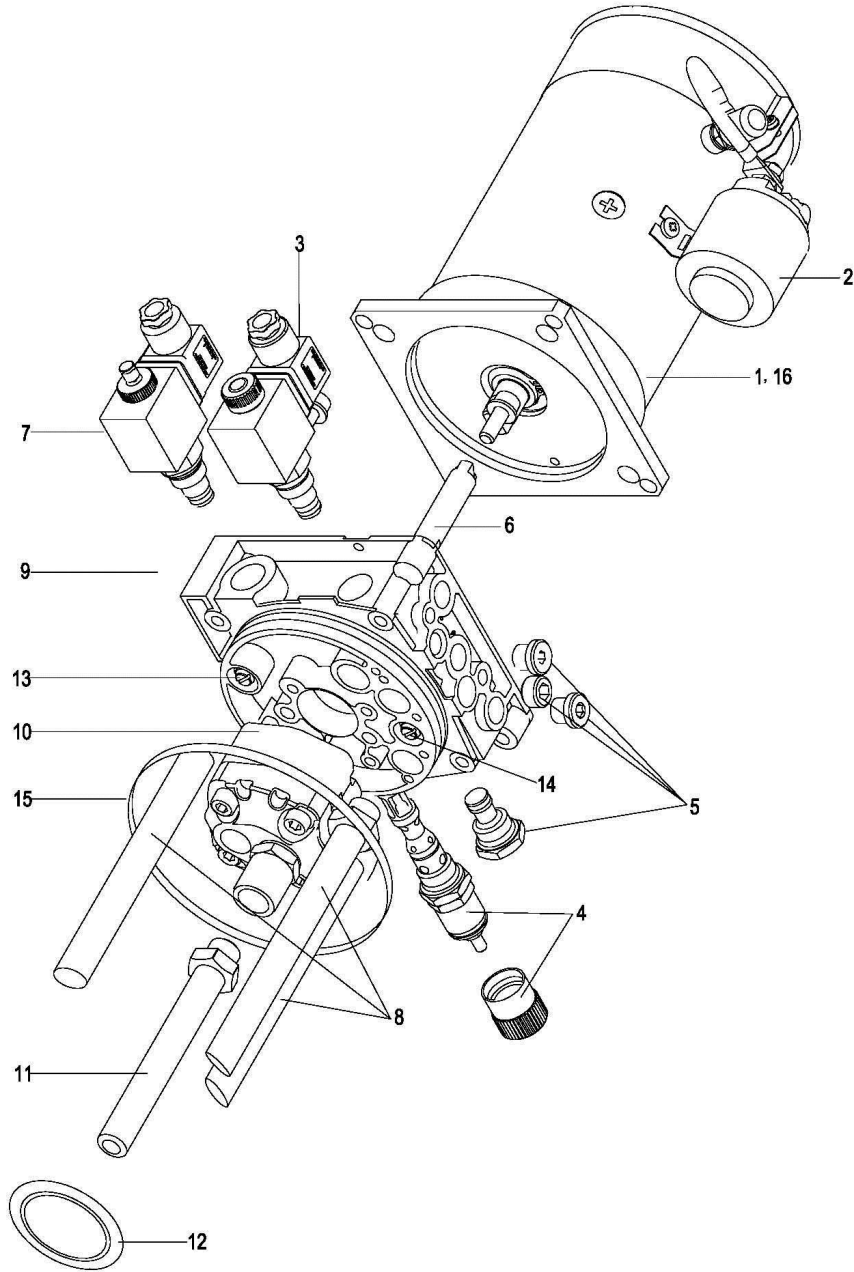

R6820

Figure 12-33 Pump & Motor Assembly - Not when side shift option
Please check part number on Assembly - Part Number 2130-430000-00

PUMP & MOTOR ASSEMBLY - NOT WHEN SIDE SHIFT OPTION

PLEASE CHECK PART NUMBER ON ASSEMBLY - PART NUMBER 2130-430000-00

Pos.	Part Number	Description	Qty. Reqd.	Notes
--	2130-430000-00	PUMP & MOTOR ASSEMBLY	1	
1	2130-430001-00	MOTOR	1	
2	2130-430002-00	CONTACTOR	1	
3	2130-430003-00	SOLENOID VALVE	1	
4	2130-430004-00	RELIEF VALVE	1	
5	2130-430005-00	SCREW	4	
6	2130-430006-00	REACH	1	
7	2130-430007-00	SOLENOID VALVE	1	
8	2130-430008-00	RETURN TUBE	1	
9	2130-430009-00	ADAPTER	1	
10	2130-430010-00	PUMP	1	
11	2130-430011-00	SUCK TUBE	1	
12	2130-430012-00	FILTER , STEEL	1	
13	2130-430013-00	FLOW CONTROL VALVE 12L/MIN	1	
14	2130-430014-00	FLOW CONTROL VALVE 6L/MIN	1	
15	2130-430015-00	RING	1	
16	2130-430016-00	BRUSH	1	

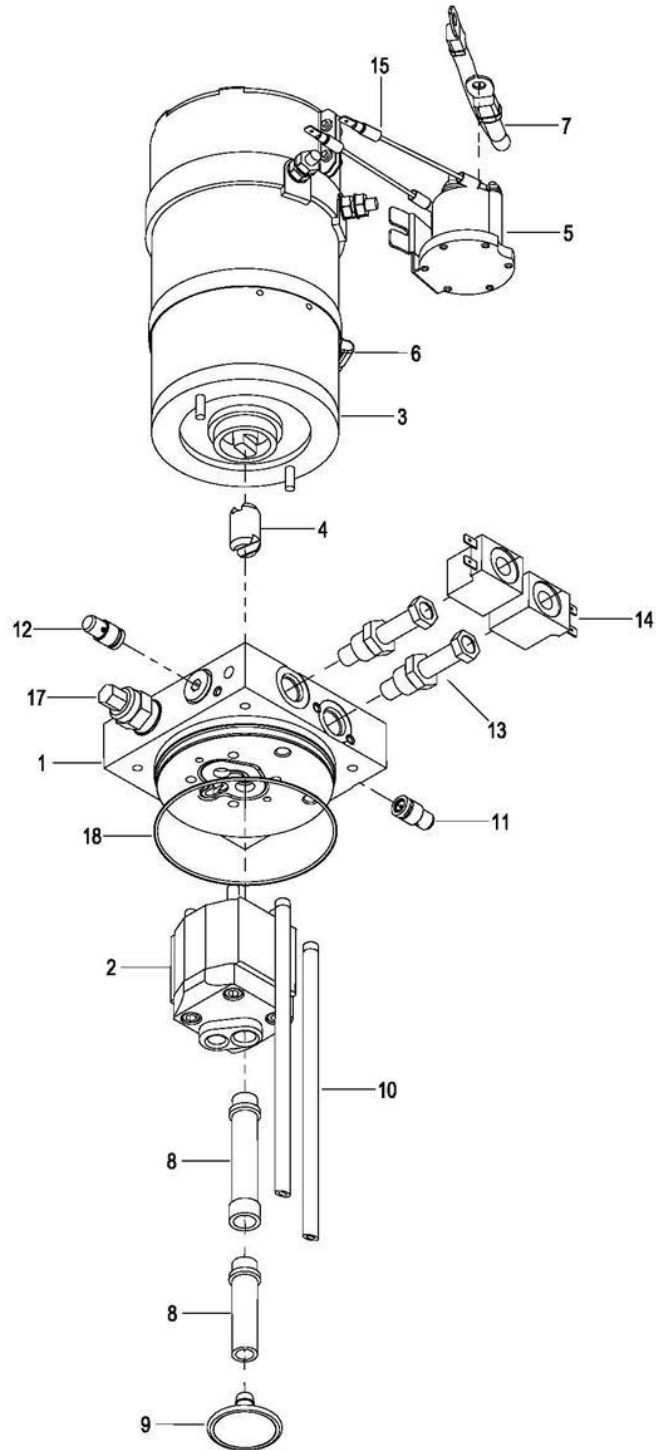

R8059

**Figure 12-34 Pump & Motor Assembly - Not when side shift option
Please check part number on Assembly - Part Number 2130-430000-0A**

PUMP & MOTOR ASSEMBLY - NOT WHEN SIDE SHIFT OPTION
PLEASE CHECK PART NUMBER ON ASSEMBLY - PART NUMBER 2130-430000-0A

Pos.	Part Number	Description	Qty. Reqd.	Notes
--	2130-430000-0A	PUMP & MOTOR ASSEMBLY	1	
1	2130-430001-0A	ADAPTER	1	
2	2130-430002-0A	PUMP	1	
3	2130-430003-0A	MOTOR	1	
4	2130-430004-0A	REACH	1	
5	1120-420017-00	CONTACTOR	1	
6	2130-430006-0A	CLAMP	1	
7	2130-430007-0A	CABLE	1	
8	2130-430008-0A	SUCK TUBE	2	
9	2130-430009-0A	FILTER , STEEL	1	
10	2130-430010-0A	RETURN TUBE	2	
11	2130-430011-0A	FLOW CONTROL VALVE GPM2.0	1	
12	2130-430012-0A	FLOW CONTROL VALVE GPM3.0	1	
13	1120-420010-00	RELEASE VALVE	2	
14	1120-420011-00	SOLENOID VALVE	2	
15	2130-430015-0A	WIRE	2	
16	2130-430016-0A	BRUSH	1	
17	2130-430017-0A	RELIEF VALVE	1	
18	2130-430018-0A	O-RING 107.32×5.33	1	

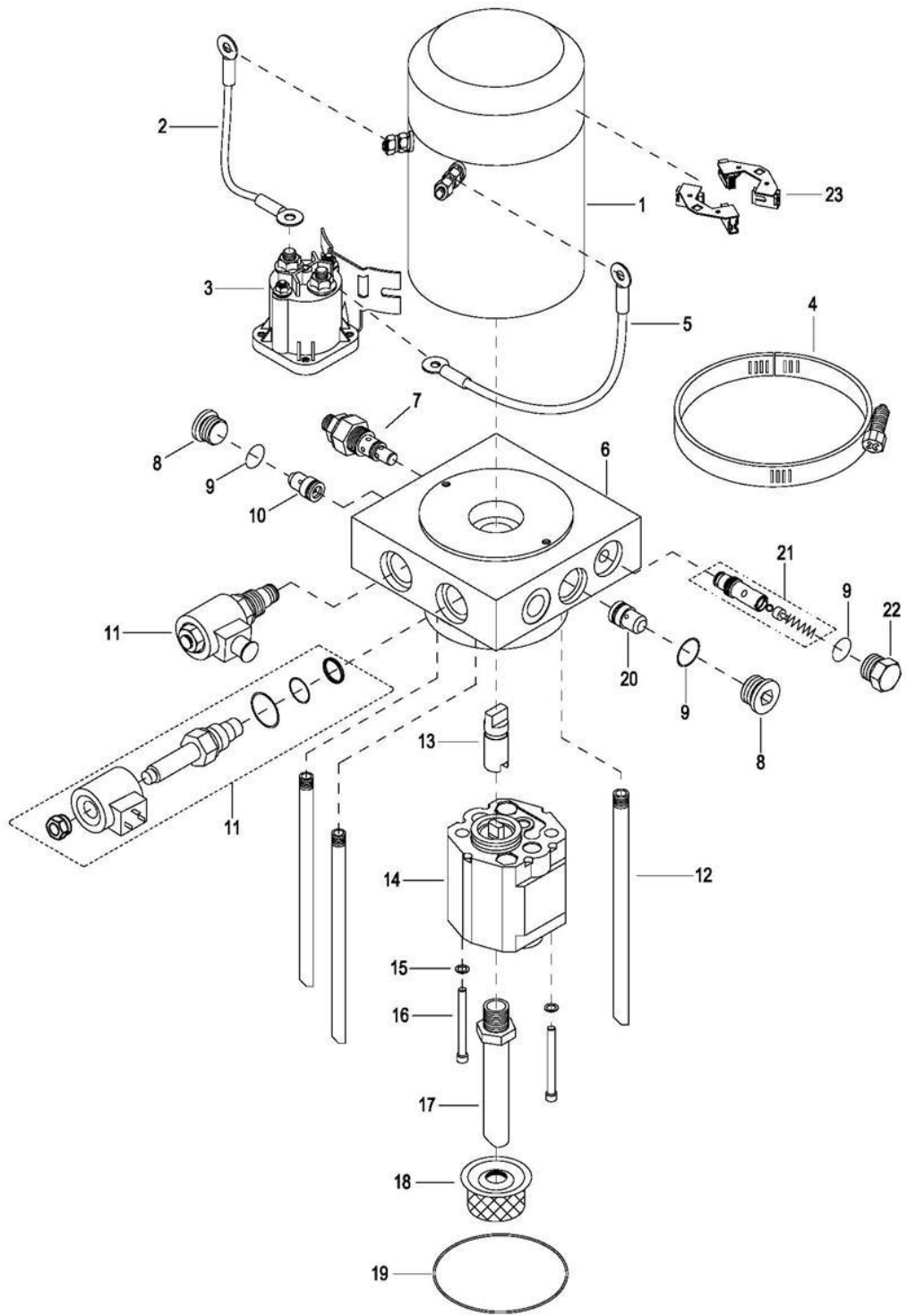

DC_0060

**Figure 12-35 Pump & Motor Assembly - Not when side shift option
Please check part number on Assembly - Part Number 2214-413000-00**

PUMP & MOTOR ASSEMBLY - NOT WHEN SIDE SHIFT OPTION
PLEASE CHECK PART NUMBER ON ASSEMBLY - PART NUMBER 2214-413000-00

Pos.	Part Number	Description	Qty. Reqd.	Notes
--	2214-413000-00	PUMP & MOTOR ASSEMBLY	1	
1	2214-413001-00	MOTOR	1	
2	2214-413002-00	WIRE	1	
3	1115-560002-00	CONTACTOR	1	
4	2214-413004-00	CLAMP D130	1	
5	2214-413005-00	WIRE	1	
6	2218-421003-00	ADAPTER	1	
7	2320-470007-00	SAFE VALVE	1	
8	1115-560026-00	PLUG	2	
9	1115-560025-00	O-RING 16.36X2.21	3	
10	2214-413010-00	FLOW VALVE	1	
11	2218-421001-00	SOLENOID VALVE	2	
12	2214-413012-00	RETURN TUBE	3	
13	1115-560010-00	SHAFT	1	
14	2214-413014-00	PUMP 3.7CC/R	1	
15	2320-470012-00	PLATWASHER 8	2	
16	2214-413016-00	SCREW M8X90	2	
17	2214-413017-00	SUCK TUBE	1	
18	2320-470015-00	FILTER	1	
19	2320-470020-0A	O-RING 100X3.55	1	
20	2218-413011-00	FLOW CONTROL VALVE	1	
21	2320-470022-00	CHECK VALVE	1	
22	2214-413022-00	PLUG	1	
23	2214-413023-00	BRUSH	1	

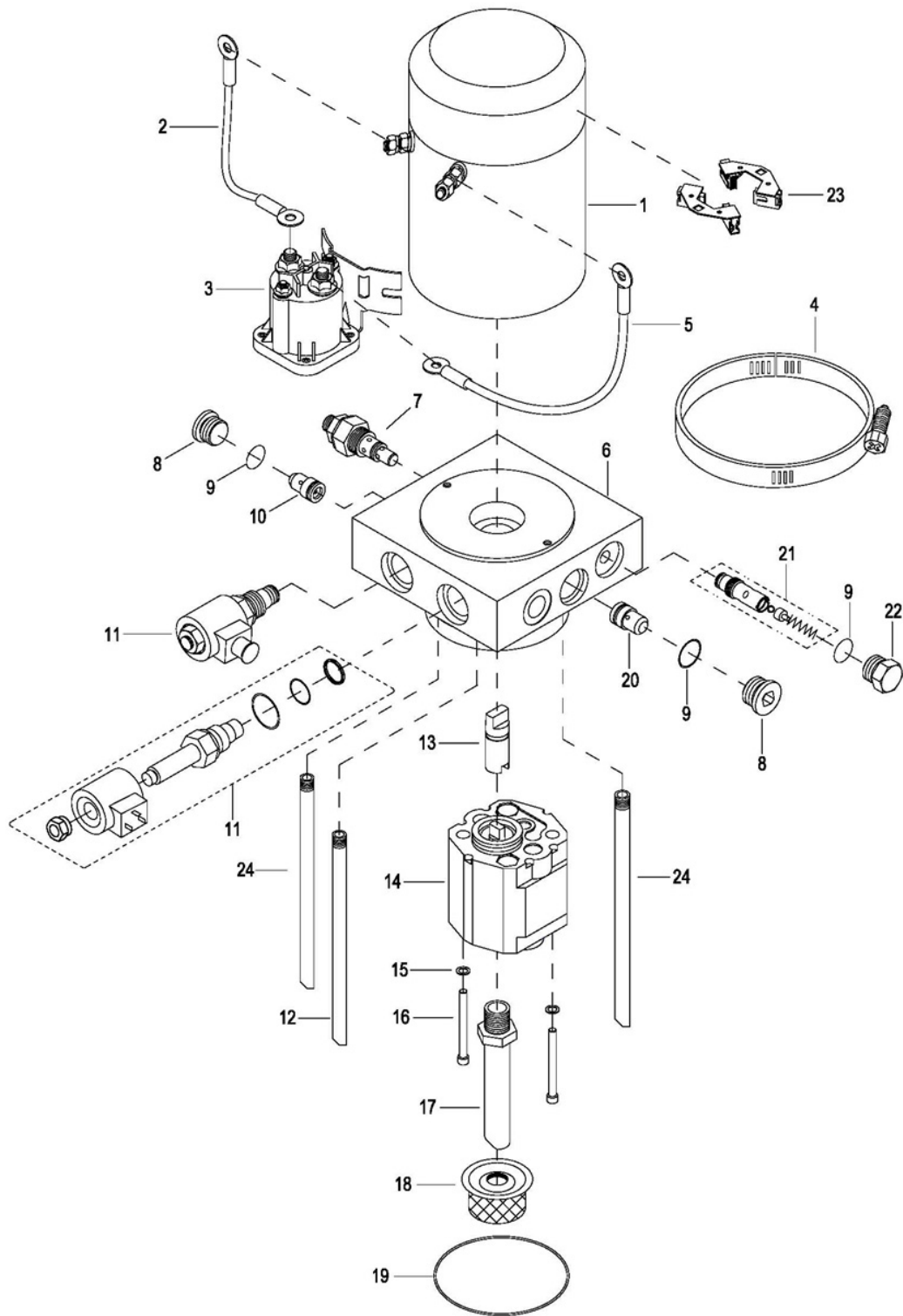

DC_0061

Figure 12-36 Pump & Motor Assembly - Not when side shift option
Please check part number on Assembly - Part Number 2218-421000-00

PUMP & MOTOR ASSEMBLY - NOT WHEN SIDE SHIFT OPTION
PLEASE CHECK PART NUMBER ON ASSEMBLY - PART NUMBER 2218-421000-00

Pos.	Part Number	Description	Qty. Reqd.	Notes
--	2218-421000-00	PUMP & MOTOR ASSEMBLY	1	
1	2214-413001-00	MOTOR	1	
2	2214-413002-00	WIRE	1	
3	2214-413003-00	CONTACTOR	1	
4	2214-413004-00	CLAMP D130	1	
5	2214-413005-00	WIRE	1	
6	2218-421003-00	ADAPTER	1	
7	2214-413007-00	SAFE VALVE	1	
8	2214-413008-00	PLUG	2	
9	2214-413009-00	O-RING 16.36X2.21	3	
10	2214-413010-00	FLOW VALVE	1	
11	2218-421001-00	SOLENOID VALVE	2	
12	2214-413012-00	RETURN TUBE	3	
13	2214-413013-00	SHAFT	1	
14	2214-413014-00	PUMP 3.7CC/R	1	
15	2214-413015-00	PLATWASHER 8	2	
16	2214-413016-00	SCREW M8X90	2	
17	2214-413017-00	SUCK TUBE	1	
18	2214-413018-00	FILTER	1	
19	2214-413019-00	O-RING 100X3.55	1	
20	2218-421002-00	FLOW CONTROL VALVE	1	
21	2214-413021-00	CHECK VALVE	1	
22	2214-413022-00	PLUG	1	
23	2214-413023-00	BRUSH	1	
24	2112-413019-50	RETURN PIPE	2	

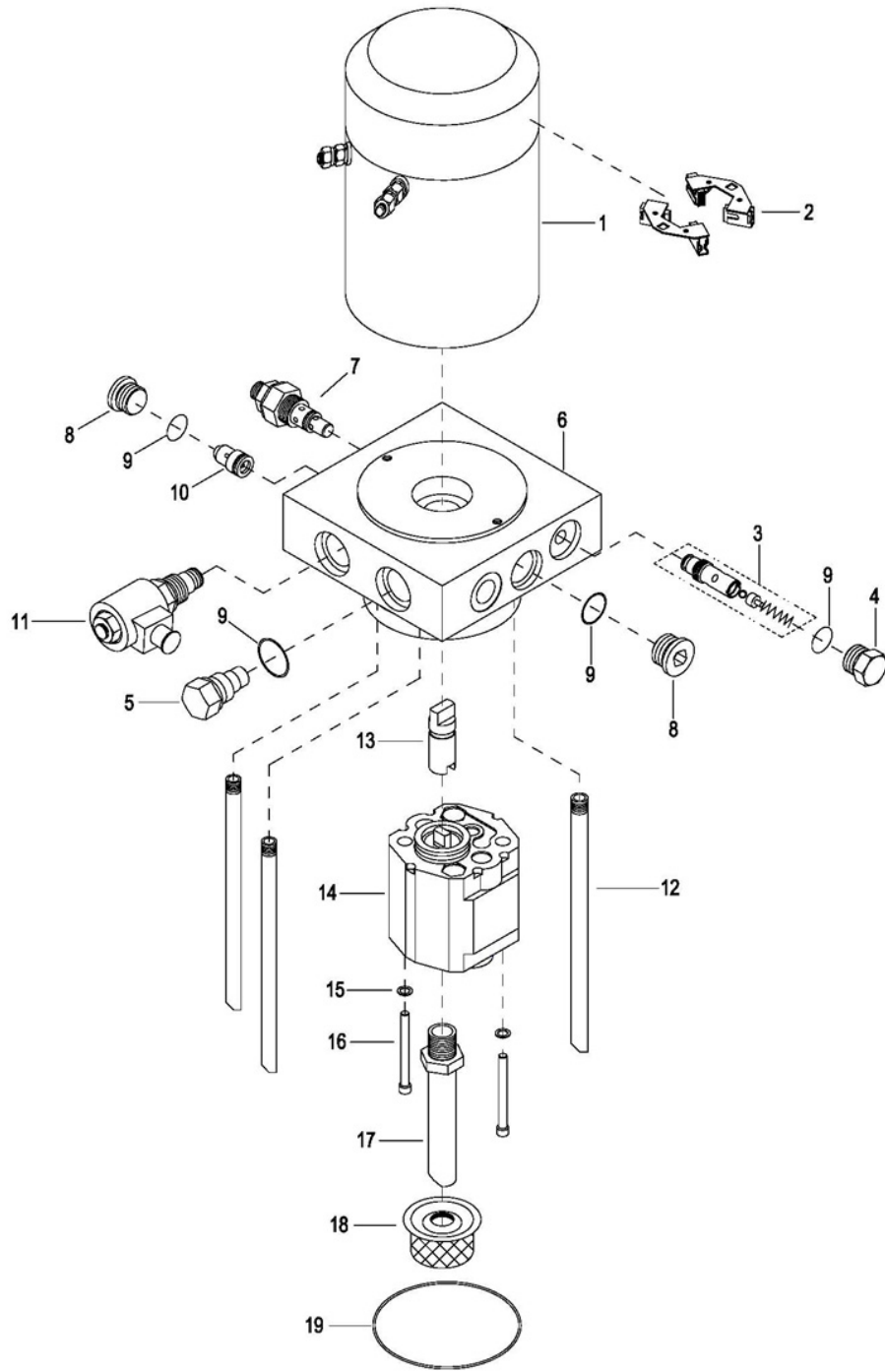

DC_0065

**Figure 12-37 Pump & Motor Assembly - Not when side shift option
Please check part number on Assembly - Part Number 2218-421000-P0**

**PUMP & MOTOR ASSEMBLY
PROP. VALVE - FROM SERIAL NUMBER 3281901819 - NOT WHEN SIDE SHIFT OPTION**

Pos.	Part Number	Description	Qty. Reqd.	Notes
--	2218-421000-P0	PUMP & MOTOR ASSEMBLY	1	
1	2214-413001-00	MOTOR	1	
2	2214-413023-00	BRUSH	1	
3	2214-413021-00	CHECK VALVE	1	
4	2214-413022-00	PLUG	1	
5	2218-421001-P0	PLUG	1	
6	2218-421003-00	ADAPTER	1	
7	2214-413007-00	SAFE VALVE	1	
8	2214-413008-00	PLUG	1	
9	2214-413009-00	O-RING 16.36X2.21	4	
10	2214-413010-00	FLOW VALVE	1	Used between serial number 3281901819 - 3292102521
10a	2218-42101X-P0	FLOW VALVE	1	Used from serial number 3292102522
11	2217-421003-P0	PROPORTIONAL SOLENOID VALVE	1	
12	2214-413012-00	RETURN TUBE	1	
13	2214-413013-00	SHAFT	1	
14	2214-413014-00	PUMP 3.7CC/R	1	
15	2214-413015-00	PLATWASHER 8	1	
16	2214-413016-00	SCREW M8X90	1	
17	2214-413017-00	SUCK TUBE	1	
18	2214-413018-00	FILTER	1	
19	2214-413019-00	O-RING 100X3.55	1	

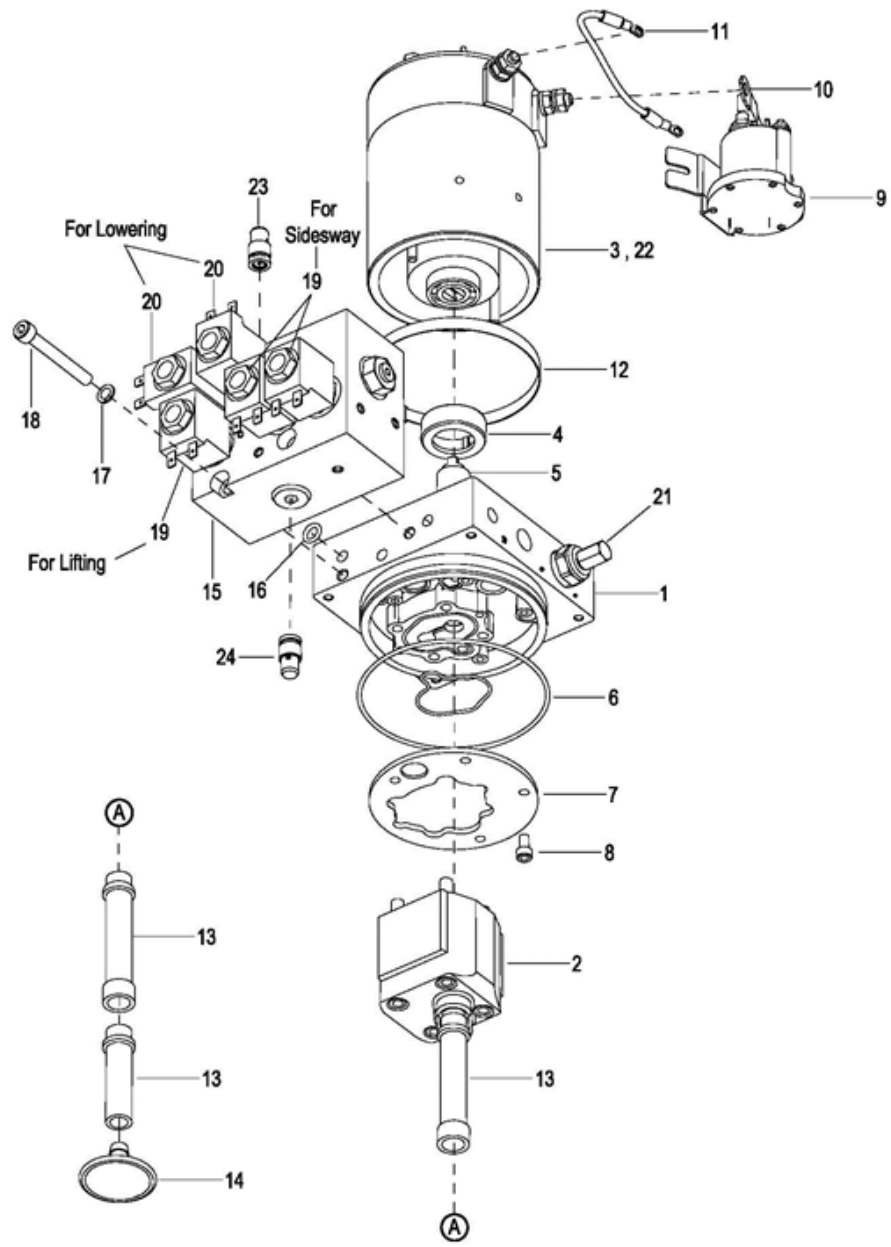

R8060

Figure 12-38 Pump & Motor Assembly (Used when Side Shift Option on truck)

**PUMP & MOTOR ASSEMBLY
(USED WHEN SIDE SHIFT OPTION ON TRUCK)**

Pos.	Part Number	Description	Qty. Reqd.	Notes
--	2130-470000-40	PUMP & MOTOR ASSEMBLY	1	
1	2320-421001-00	ADAPTER	1	
2	2320-421002-00	PUMP	1	
3	2130-470002-40	MOTOR	1	
4	2320-421004-00	BUSH	1	
5	2320-421005-00	COUPLING	1	
6	2320-421006-00	SEAL KIT	1	
7	2320-421007-00	FILTER SCREEN	1	
8	0000-000077-00	SCREW M6×12	4	
9	2320-421008-00	RELAY	1	
10	2320-421009-00	CABLE INSULATED	1	
11	2320-421010-00	WIRE	1	
12	2320-421011-00	STEE CLAMP	1	
13	2320-421012-00	TUBE PLASTIC	3	
14	2320-421013-00	FILTER , STEEL	1	
15	2320-421014-00	MANIFOLD	1	
16	2320-421015-00	O-RING	2	
17	0000-000159-00	LOCKWASHER Ø8	2	
18	0000-000110-00	SCREW M8×65	2	
19	2320-421016-00	SOLENOID VALVE I	3	Used for Lift and Side Shift
20	2320-421017-00	SOLENOID VALVE II	2	Used for Lowering
21	2320-421018-00	RELIEF VALVE	1	
22	2130-470003-40	BRUSH	1	
23	2130-470001-40	FLOW CONTROL VALVE 6 L/MIN	1	
24	2130-430012-0A	FLOW CONTROL VALVE GPM 3.0	1	

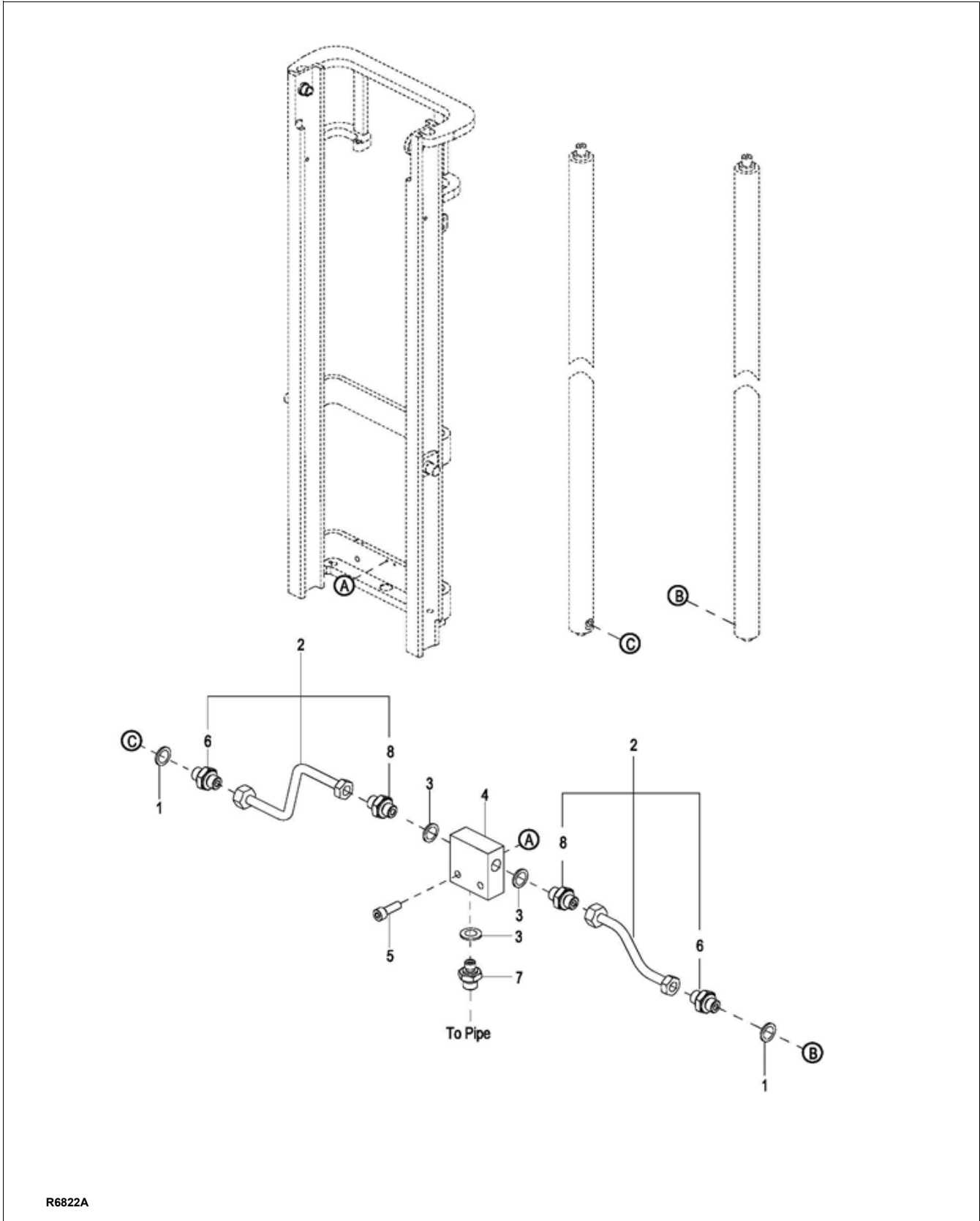

R6822A

Figure 12-39 Hydraulic Lines (Telescopic) - Not when side shift option - Used up to 12-14-2011

HYDRAULIC LINES (TELESCOPIC) - NOT WHEN SIDE SHIFT OPTION (USED UP TO 12-14-2011)

Pos.	Part Number	Description	Qty. Reqd.	Notes
1	0000-000069-00	WASHER Ø16	2	
2	2130-400002-00-B	METALLIC PIPE ASSEMBLY	2	
3	0000-000044-00	WASHER Ø14	5	
4	2130-400001-00	BLOCK TEE	1	
5	0000-000154-00	SCREW M8×35	2	
6	2801-161601-00	CONNECTOR G1/4-M16×1.5	2	
7	2702-141600-00	CONNECTOR G1/4-M16×1.5	1	
8	2802-141601-00	CONNECTOR M16×1.5-M16×1.5	2	

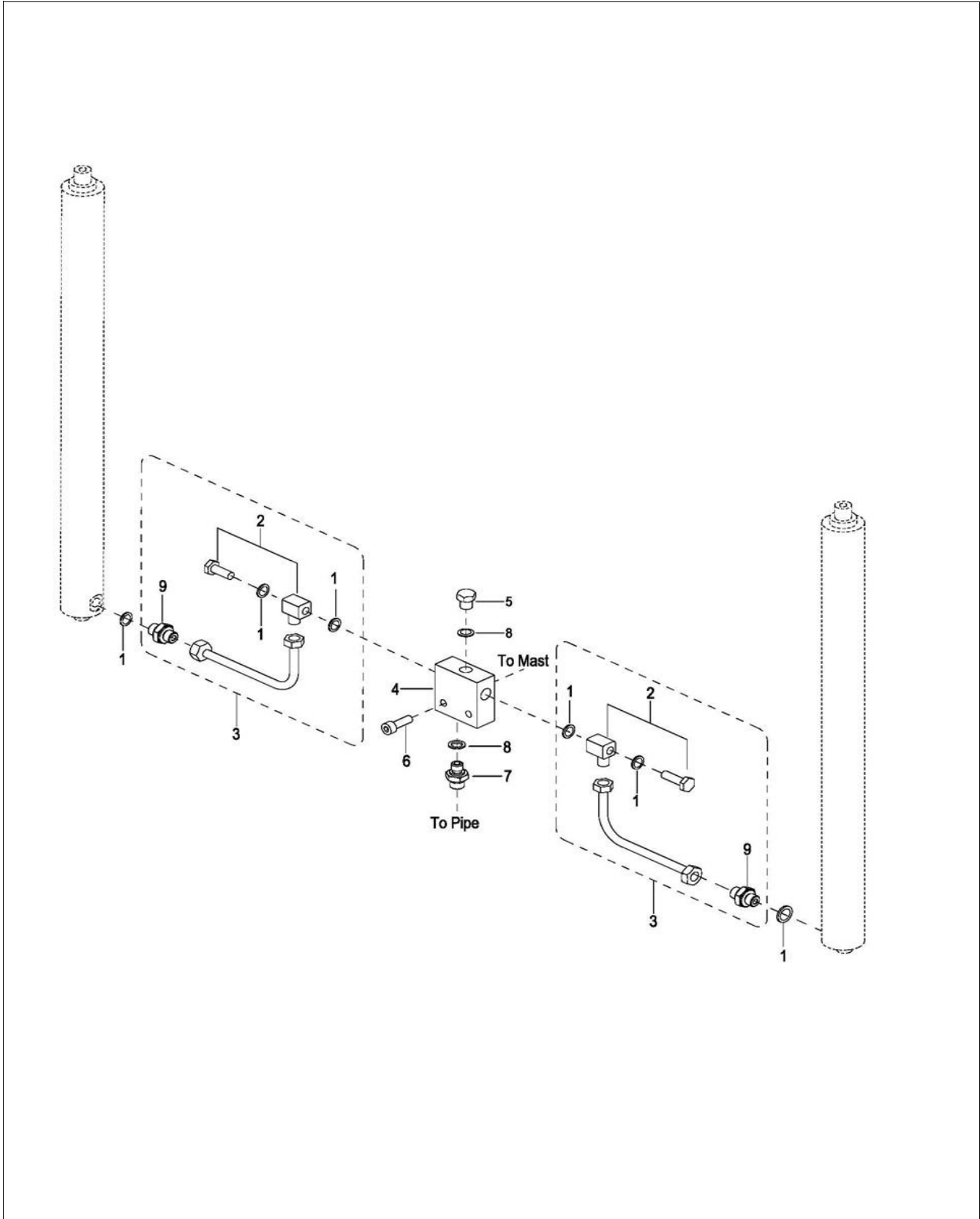
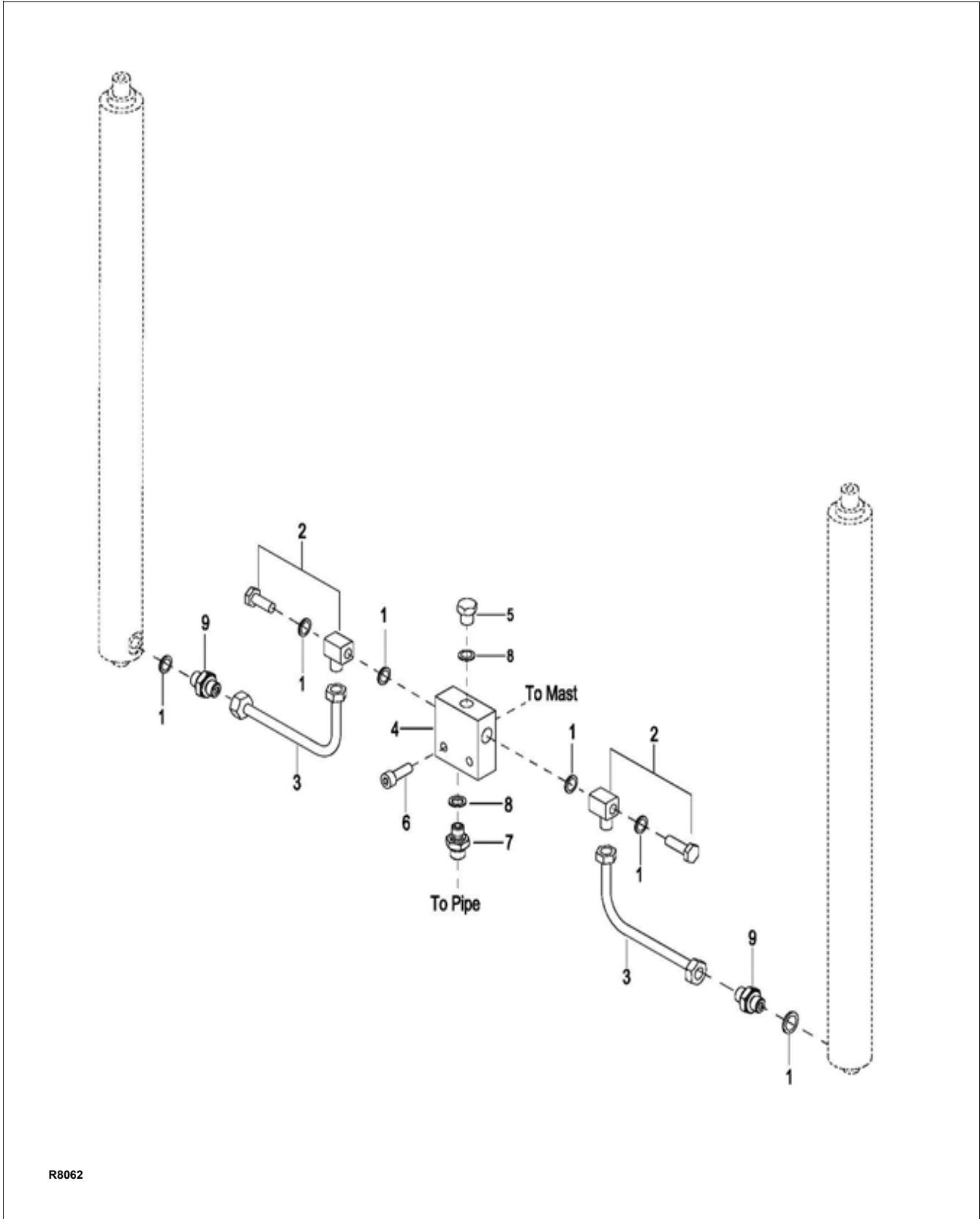

Figure 12-40 Hydraulic Lines (Telescopic) Not when side shift - Used between 12-15-2011 and 12-26-2012

**HYDRAULIC LINES (TELESCOPIC) - NOT WHEN SIDE SHIFT OPTION
(USED BETWEEN 12-15-2011 AND 12-26-2012)**

Pos.	Part Number	Description	Qty. Reqd.	Notes
1	0000-000069-00	WASHER Ø16	6	
2	2805-160010-20	BOLT M16×1.5	2	
3	2130-400002-0A-B	METALLIC PIPE ASSEMBLY	2	
4	2125-400002-3A	BLOCK CROSS	1	
5	2712-141300-00	PLUG G1/4	1	
6	0000-000169-00	SCREW M8×30	2	
7	2702-141600-00	UNION	1	
8	0000-000044-00	WASHER Ø14	2	
9	2801-161601-00	CONNECTOR G1/4-M16×1.5	2	



R8062

Figure 12-41 Hydraulic Lines (Telescopic) Not when side shift
 - Used from 12-27-2012 to Serial Number 326170592

**HYDRAULIC LINES (TELESCOPIC) - NOT WHEN SIDE SHIFT OPTION
(USED FROM 12-27-2012 TO SERIAL NUMBER 326170592)**

Pos.	Part Number	Description	Qty. Reqd.	Notes
1	0000-000069-00	WASHER Ø16	6	
2	2706-161600-00	CONNECTOR M16×1.5-M16×1.5	2	
3	2130-470000-00	METALLIC PIPE ASSEMBLY	2	
4	2125-400002-3A	BLOCK CROSS	1	
5	2712-141300-00	PLUG G1/4	1	
6	0000-000169-00	SCREW M8×30	2	
7	2702-141600-00	CONNECTOR G1/4-M16×1.5	1	
8	0000-000044-00	WASHER Ø14	2	
9	2701-161600-00	CONNECTOR M16×1.5-M16×1.5	2	

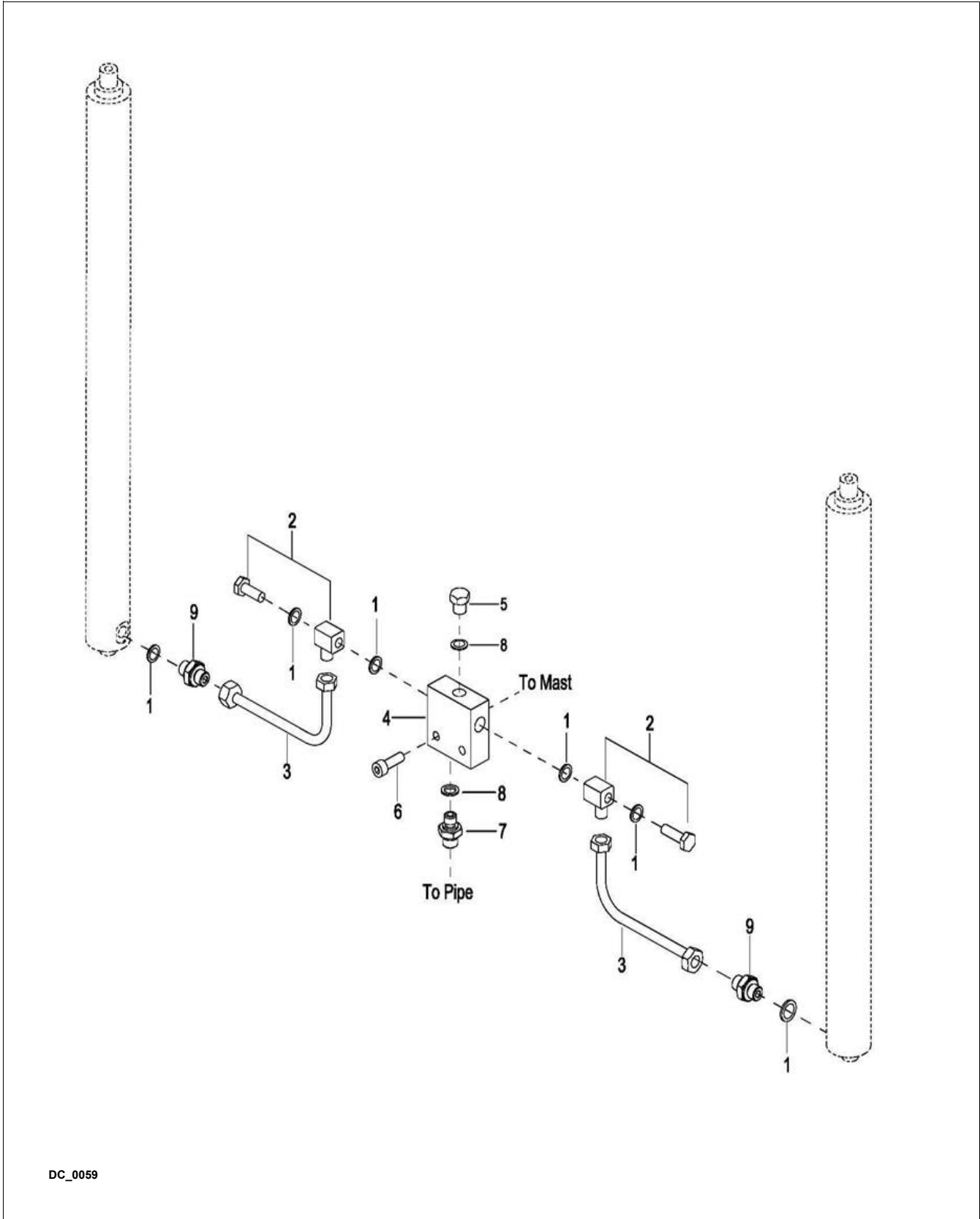

DC_0059

**Figure 12-42 Hydraulic Lines (Telescopic) Not when side shift
- Used between Serial Number 326170593 - 3281500026**

**HYDRAULIC LINES (TELESCOPIC) - NOT WHEN SIDE SHIFT OPTION
(USED BETWEEN SERIAL NUMBER 326170593 - 3281500026)**

Pos.	Part Number	Description	Qty. Reqd.	Notes
1	0000-000069-00	WASHER Ø16	6	
2	2706-161600-00	CONNECTOR M16×1.5-M16×1.5	2	
3	2130-470000-00	METALLIC PIPE ASSEMBLY	2	
4	2333-430001-30	BLOCK CROSS	1	
5	2712-201300-00	PLUG M20x1.5	1	
6	0000-000169-00	SCREW M8×30	2	
7	2701-201600-00	CONNECTOR M20x1.5-M16×1.5	1	
8	3060-010000-04	WASHER Ø20	2	
9	2701-161600-00	CONNECTOR M16×1.5-M16×1.5	2	

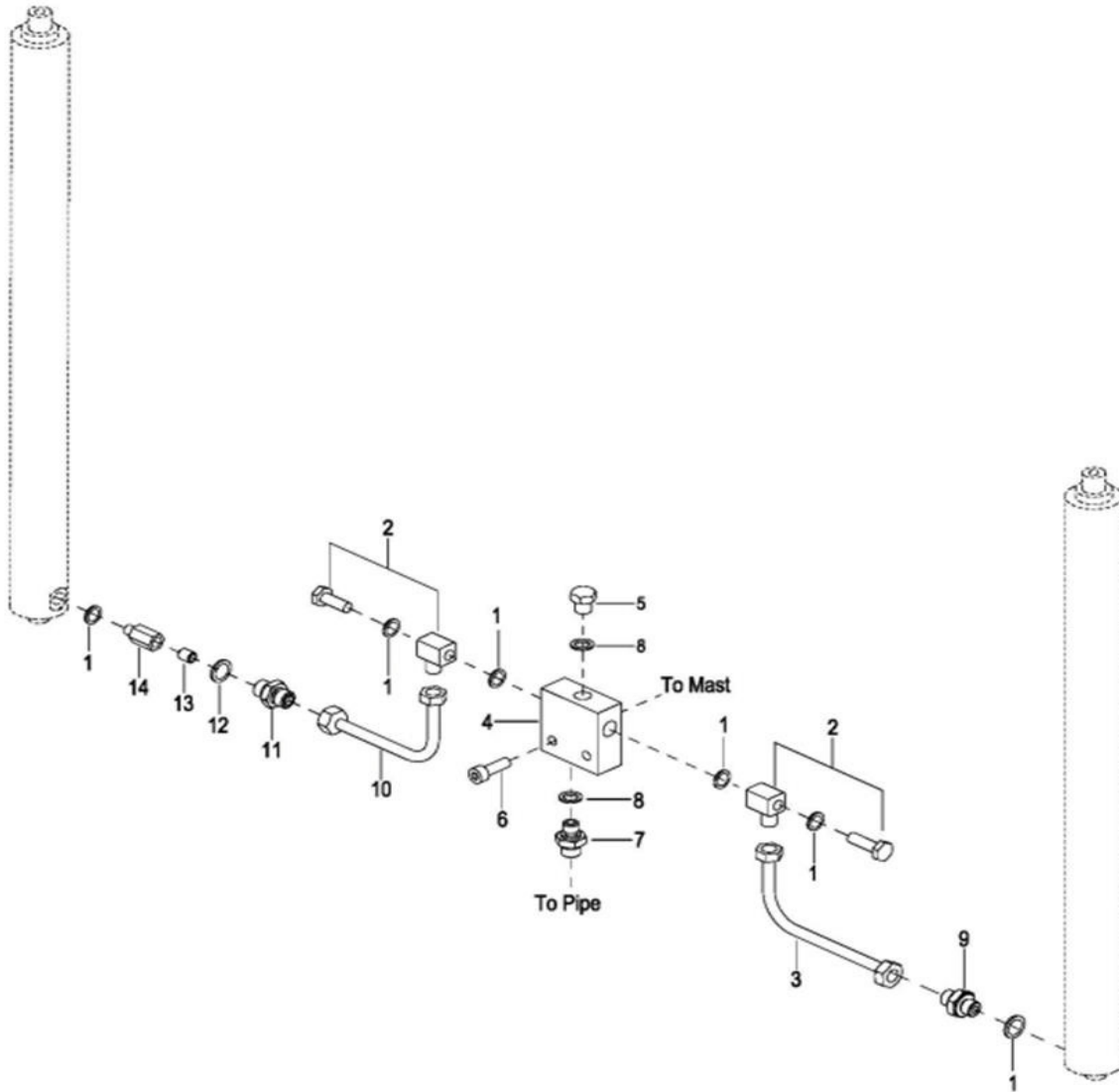

DC_0070

**Figure 12-43 Hydraulic Lines (Telescopic) Not when side shift
 - Used from Serial Number 328150027**

**HYDRAULIC LINES (TELESCOPIC) - NOT WHEN SIDE SHIFT OPTION
(USED FROM SERIAL NUMBER 3281500027)**

Pos.	Part Number	Description	Qty. Reqd.	Notes
1	0000-000069-00	WASHER Ø16	6	
2	2706-161600-00	CONNECTOR M16×1.5-M16×1.5	2	
3	2130-470000-00	METALLIC PIPE ASSEMBLY	1	
4	2333-430001-30	BLOCK CROSS	1	
5	2712-201300-00	PLUG M20×1.5	1	
6	0000-000169-00	SCREW M8×30	2	
7	2702-141600-00	CONNECTOR G1/4X1.5-M16X1.5	1	
8	0000-000044-00	WASHER Ø18	2	
9	2701-161600-00	CONNECTOR M16×1.5-M16×1.5	1	
10	2130-411000-R0	METALLIC PIPE ASSEMBLY	1	
11	2702-381600-10	CONNECTOR G3/8-M16×1.5	1	
12	0000-000634-00	WASHER Ø18	1	
13	2214-411000-R0	EXPLOSION RELIEF VALVE	1	
14	CK10-400001-3C	CONNECTOR M16×1.5-G3/8	1	

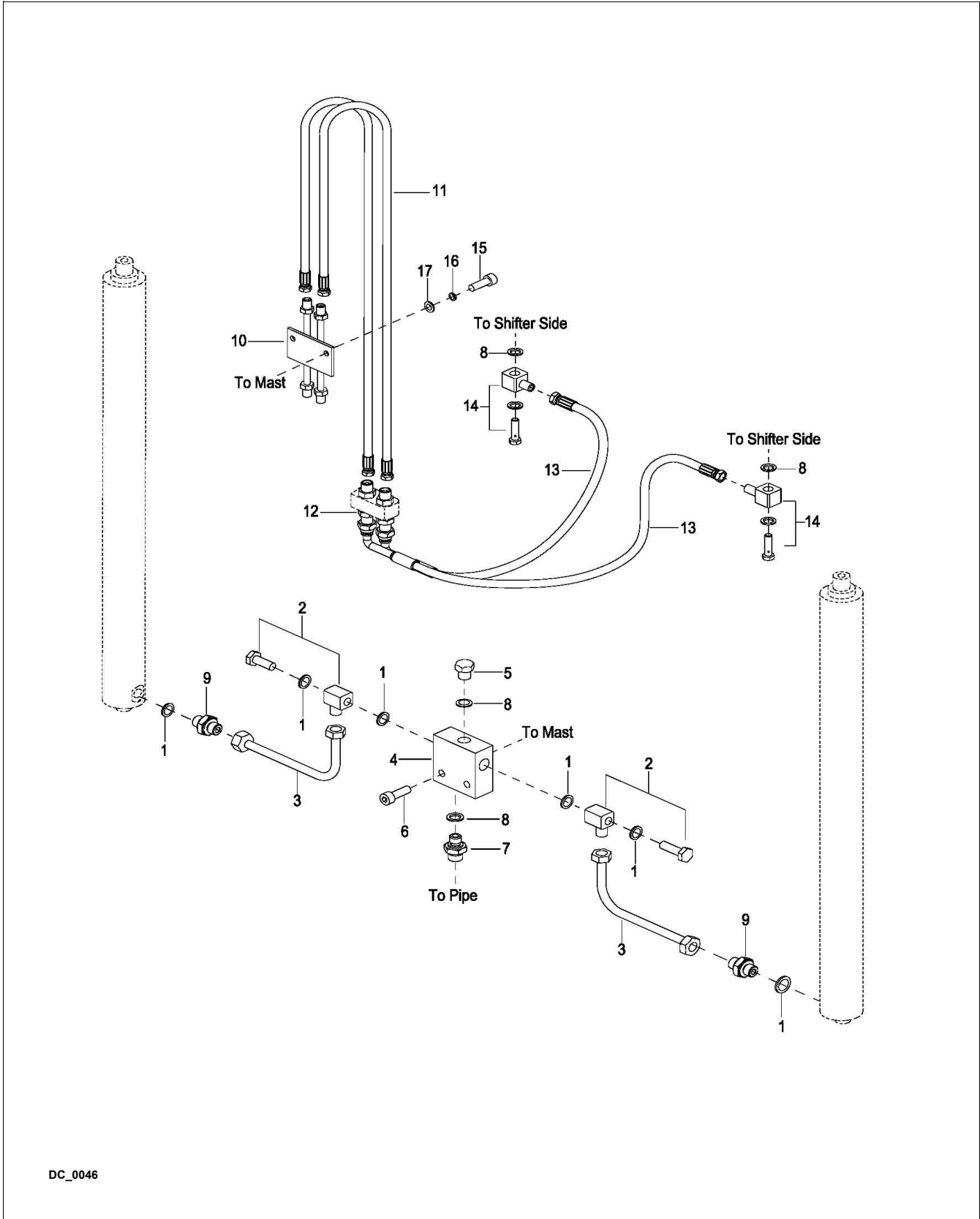

DC_0046

Figure 12-44 Hydraulic Lines (Telescopic) - Used up to serial number 3281500026 when side shift option

**HYDRAULIC LINES (TELESCOPIC) - USED UP TO SERIAL NUMBER 3281500026
WHEN SIDE SHIFT OPTION**

Pos.	Part Number	Description	Qty. Reqd.	Notes
1	0000-000069-00	WASHER Ø16	6	
2	2706-161600-00	CONNECTOR M16×1.5-M16×1.5	2	
3	2130-470000-00	METALLIC PIPE ASSEMBLY	2	
4	2125-400002-3A	VALVE BLOCK	1	
5	2712-141300-00	PLUG G1/4	1	
6	0000-000169-00	SCREW M8×30	2	
7	2702-141600-00	CONNECTOR G1/4-M16×1.5	1	
8	0000-000044-00	WASHER Ø14	4	
9	2701-161600-00	CONNECTOR M16×1.5-M16×1.5	2	
10	3218-724000-00	METAL TUBE	1	
11	2130-440000-10-01	OIL PIPE	2	Used for lift height 104" - Telescopic
11a	2130-440000-10-02	OIL PIPE	2	Used for lift height 126" - Telescopic
11b	2130-440000-10-03	OIL PIPE	2	Used for lift height 142" - Telescopic
12	3215-860300-10	CONNECTOR M14×1.5-M14×1.5	2	
13	2130-450000-10	OIL PIPE	2	
14	2706-141400-00	CONNECTOR M14×1.5-M14×1.5	2	
15	0000-000109-00	SCREW M8×16	2	
16	0000-000159-00	LOCKWASHER Ø8	2	
17	0000-000176-00	FLATWASHER Ø8	2	

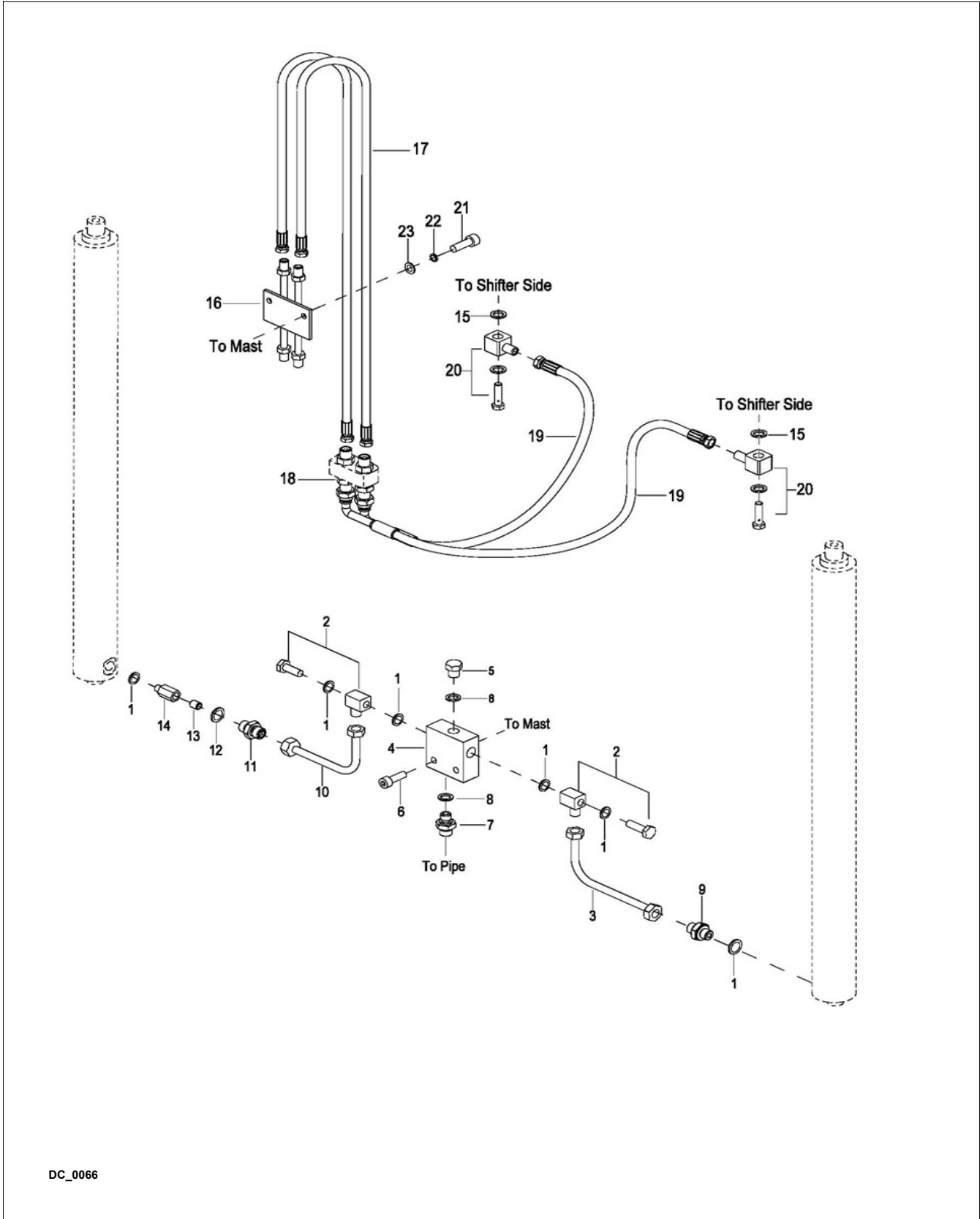
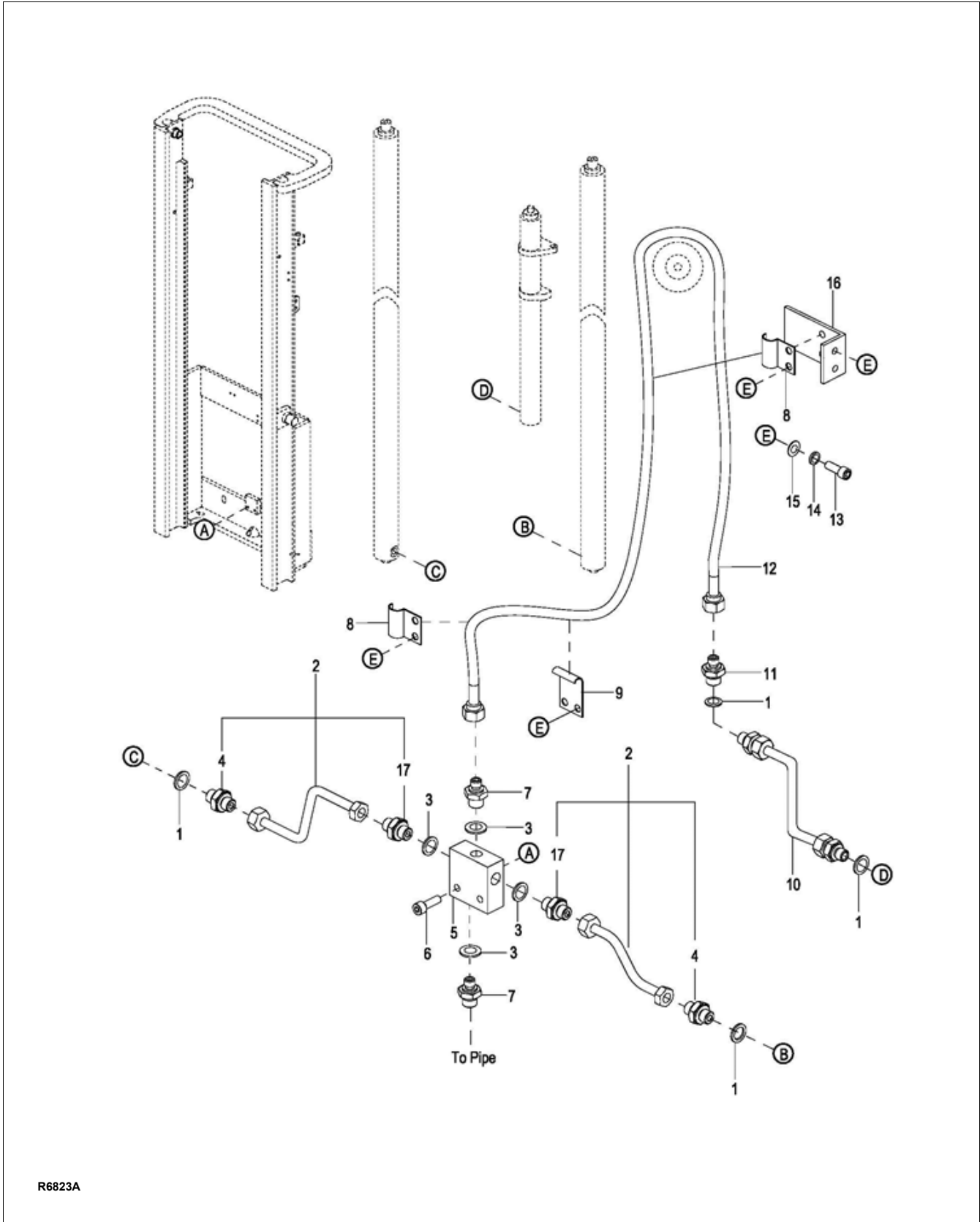

Figure 12-45 Hydraulic Lines (Telescopic) - Used from serial number 3281500027
When side shift option

**HYDRAULIC LINES (TELESCOPIC) - USED FROM SERIAL NUMBER 3281500027
WHEN SIDE SHIFT OPTION**

Pos.	Part Number	Description	Qty. Reqd.	Notes
1	0000-000069-00	WASHER Ø16	6	
2	2706-161600-00	CONNECTOR M16×1.5-M16×1.5	2	
3	2130-470000-00	METALLIC PIPE ASSEMBLY	1	
4	2125-400002-3A	VALVE BLOCK	1	
5	2712-141300-00	PLUG G1/4	1	
6	0000-000169-00	SCREW M8×30	2	
7	2702-141600-00	CONNECTOR G1/4-M16×1.5	1	
8	0000-000044-00	WASHER Ø14	2	
9	2701-161600-00	CONNECTOR M16×1.5-M16×1.5	1	
10	2130-411000-R0	METAL TUBE	1	
11	2702-381600-10	CONNECTOR G3/8-M16×1.5	1	
12	0000-000634-00	WASHER Ø18	1	
13	2214-411000-R0	EXPLOSION RELIEF VALVE	1	
14	CK10-400001-3B	CONNECTOR M16×1.5-G3/8	1	
15	0000-000044-00	WASHER Ø14	4	
16	3218-724000-00	METAL TUBE	1	
17	2130-440000-10-01	OIL PIPE	2	Used for lift height 104" - Telescopic
17a	2130-440000-10-02	OIL PIPE	2	Used for lift height 126" - Telescopic
17b	2130-440000-10-03	OIL PIPE	2	Used for lift height 142" - Telescopic
18	3215-860300-10	CONNECTOR M14×1.5-M14×1.5	2	
19	2130-450000-10	OIL PIPE	2	
20	2706-141400-00	CONNECTOR M14×1.5-M14×1.5	2	
21	0000-000109-00	SCREW M8×16	2	
22	0000-000159-00	LOCKWASHER Ø8	2	
23	0000-000176-00	FLATWASHER Ø8	2	



R6823A

Figure 12-46 Hydraulic Lines (TRIMAST) - Not when side shift option - Used up to 12-14-2011

HYDRAULIC LINES (TRIMAST) - NOT WHEN SIDE SHIFT OPTION - (USED UP TO 12-14-2011)

Pos.	Part Number	Description	Qty. Reqd.	Notes
1	0000-000069-00	WASHER Ø16	5	
2	2125-400001-30-B	METALLIC PIPE ASSEMBLY ?	2	
3	0000-000044-00	WASHER Ø14	4	
4	2801-161601-00	CONNECTOR M16×1.5-M16×1.5	2	
5	2125-400002-30	VALVE BLOCK	1	
6	0000-000154-00	SCREW M8×35	2	
7	2702-141600-00	CONNECTOR G1/4-M16×1.5	2	
8	2125-400003-30	HARNESS CLAMP ?	2	
9	2125-400006-30	HARNESS CLAMP II	1	
10	2125-400007-30-B	METALLIC PIPE ASSEMBLY ?	1	
11	2701-161600-00	CONNECTOR M16×1.5-M16×1.5	1	
12	2125-440000-30-01	HOSE	1	Used for lift height 157" - TRIMAST
12a	2125-440000-30-02	HOSE	1	Used for lift height 177" - TRIMAST
13	0000-000109-00	SCREW M8×16	8	
14	0000-000159-00	LOCKWASHER Ø8	8	
15	0000-000176-00	FLATWASHER Ø8	8	
16	2125-400004-30	CLAMP BRACKET	1	
17	2802-141601-00	CONNECTOR G1/4-M16×1.5	2	

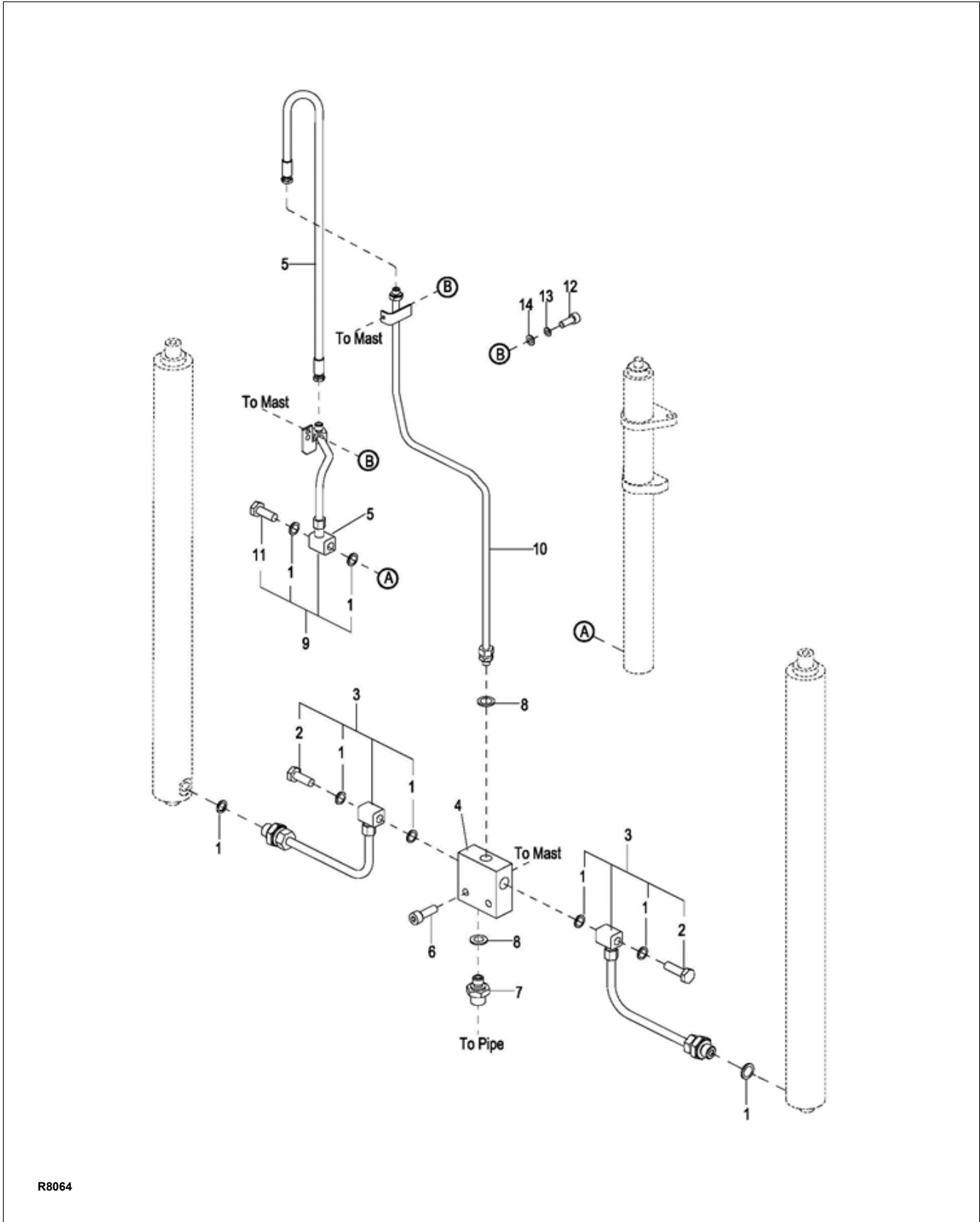

R8064

Figure 12-47 Hydraulic Lines (TRIMAST) Not when side shift - Used between 12-15-2011 and 12-26-2012

**HYDRAULIC LINES (TRIMAST) - NOT WHEN SIDE SHIFT OPTION
(USED BETWEEN 12-15-2011 AND 12-26-2012)**

Pos.	Part Number	Description	Qty. Reqd.	Notes
1	0000-000069-00	WASHER Ø16	8	
2	2805-160010-20	BOLT M16×1.5	2	
3	2130-400002-0A-B	METALLIC PIPE ASSEMBLY	2	
4	2125-400002-30	VALVE BLOCK	1	
5	2125-440000-3A-01	HOSE	1	Used for lift height 157" - TRIMAST
5a	2125-440000-3A-02	HOSE	1	Used for lift height 177" - TRIMAST
6	0000-000169-00	SCREW M8×30	2	
7	2702-141600-00	UNION	1	
8	0000-000044-00	WASHER Ø14	2	
9	2125-430000-3A-B	METALLIC PIPE ASSEMBLY	1	
10	2125-450000-30-B	METALLIC PIPE ASSEMBLY ?	1	
11	2805-160014-00	BOLT M16×1.5	1	
12	0000-000109-00	SCREW M8×16	3	
13	0000-000159-00	LOCKWASHER Ø8	3	
14	0000-000176-00	FLATWASHER Ø8	3	

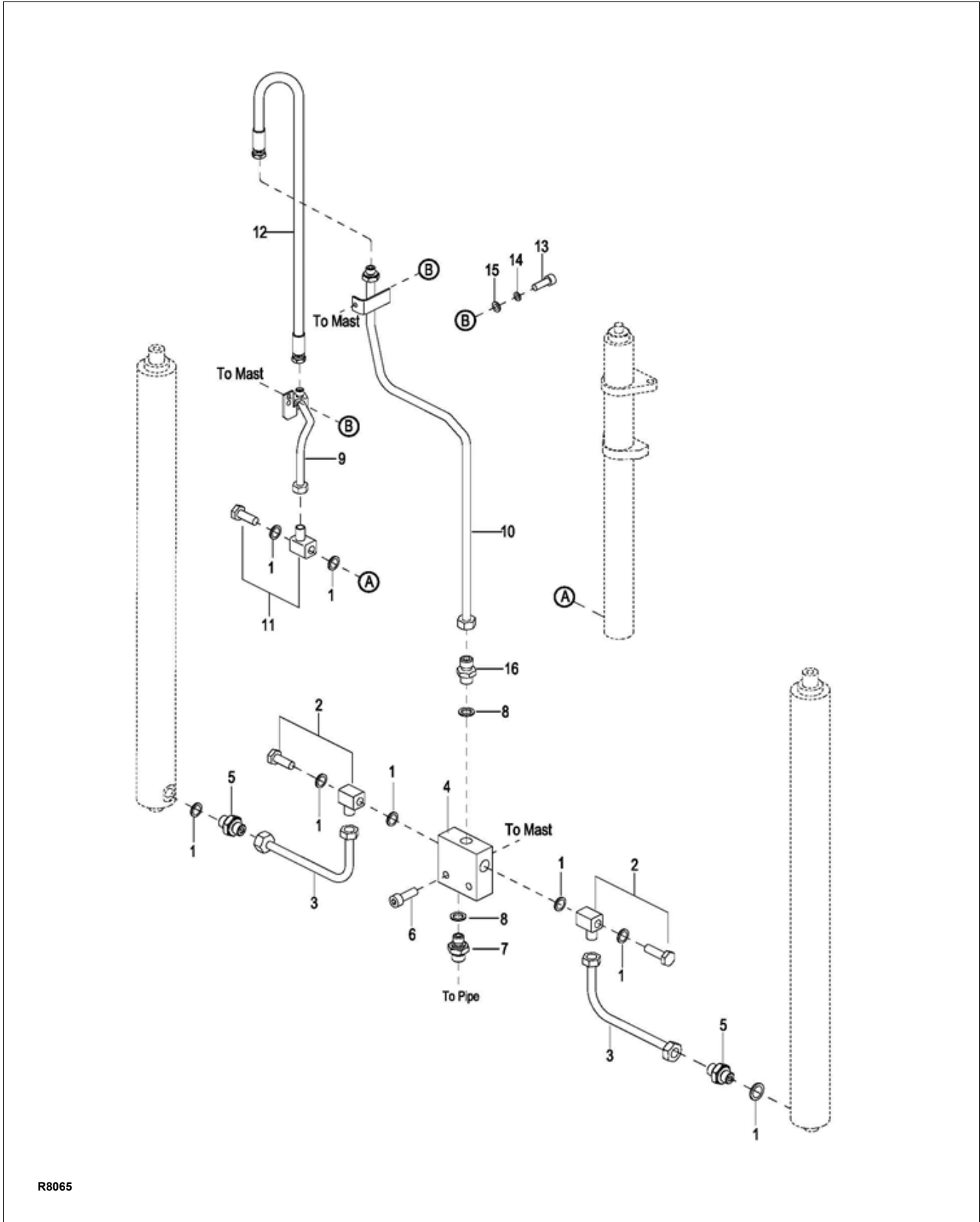

R8065

**Figure 12-48 Hydraulic Lines (TRIMAST) - Not when side shift
Used from 12-27-2012 to Serial Number 326170592**

**HYDRAULIC LINES (TRIMAST) - NOT WHEN SIDE SHIFT OPTION
(USED FROM 12-27-2012 TO SERIAL NUMBER 326170592)**

Pos.	Part Number	Description	Qty. Reqd.	Notes
1	0000-000069-00	WASHER Ø16	8	
2	2706-161600-00	CONNECTOR M16×1.5-M16×1.5	2	
3	2130-430000-30	METALLIC PIPE ASSEMBLY	2	
4	2125-400002-30	VALVE BLOCK	1	
5	2701-161600-00	CONNECTOR M16×1.5-M16×1.5	2	
6	0000-000169-00	SCREW M8×30	2	
7	2702-141600-00	CONNECTOR G1/4-M16×1.5	1	
8	0000-000044-00	WASHER Ø14	2	
9	2125-430000-3B	METALLIC OIL PIPE ASSEMBLY	1	
10	2125-450000-3A	METALLIC OIL PIPE ASSEMBLY ?	1	
11	2706-162000-10	CONNECTOR M16×1.5-M20×1.5	1	
12	2125-440000-3A-01	HOSE	1	Used for lift height 157" - TRIMAST
12a	2125-440000-3A-02	HOSE	1	Used for lift height 177" - TRIMAST
13	0000-000109-00	SCREW M8×16	3	
14	0000-000159-00	LOCKWASHER Ø8	3	
15	0000-000176-00	FLATWASHER Ø8	3	
16	2702-142000-00	CONNECTOR G1/4-M20×1.5	1	

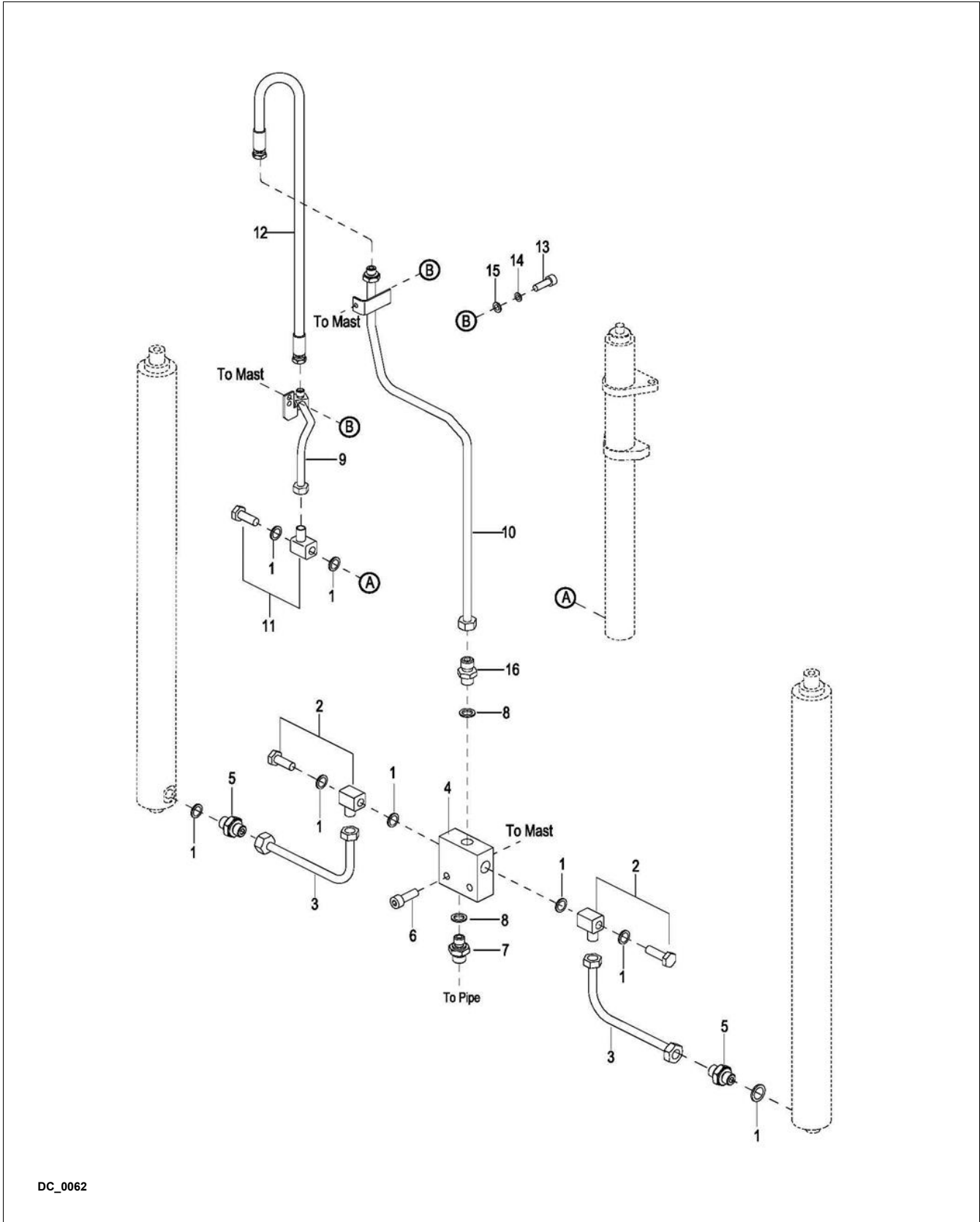

DC_0062

**Figure 12-49 Hydraulic Lines (TRIMAST) - Not when side shift
Used between Serial Number 326170593 - 328150026**

**HYDRAULIC LINES (TRIMAST) - NOT WHEN SIDE SHIFT OPTION
(USED BETWEEN SERIAL NUMBER 326170593 - 3281500026)**

Pos.	Part Number	Description	Qty. Reqd.	Notes
1	0000-000069-00	WASHER Ø16	8	
2	2706-161600-00	CONNECTOR M16×1.5-M16×1.5	2	
3	2130-430000-30	METALLIC PIPE ASSEMBLY	2	
4	2333-430001-30	VALVE BLOCK	1	
5	2701-161600-00	CONNECTOR M16×1.5-M16×1.5	2	
6	0000-000169-00	SCREW M8×30	2	
7	2701-201600-00	CONNECTOR M20×1.5-M16×1.5	1	
8	3060-010000-04	WASHER Ø20	2	
9	2333-431000-30	METALLIC OIL PIPE ASSEMBLY	1	
10	2333-432000-30	METALLIC OIL PIPE ASSEMBLY ?	1	
11	2706-162000-10	CONNECTOR M16×1.5-M20×1.5	1	
12	2333-433000-30-01	HOSE	1	Used for lift height 157" - TRIMAST
12a	2333-433000-30-02	HOSE	1	Used for lift height 177" - TRIMAST
13	0000-000109-00	SCREW M8×16	3	
14	0000-000159-00	LOCKWASHER Ø8	3	
15	0000-000176-00	FLATWASHER Ø8	3	
16	2701-202000-00	CONNECTOR M20×1.5-M20×1.5	1	

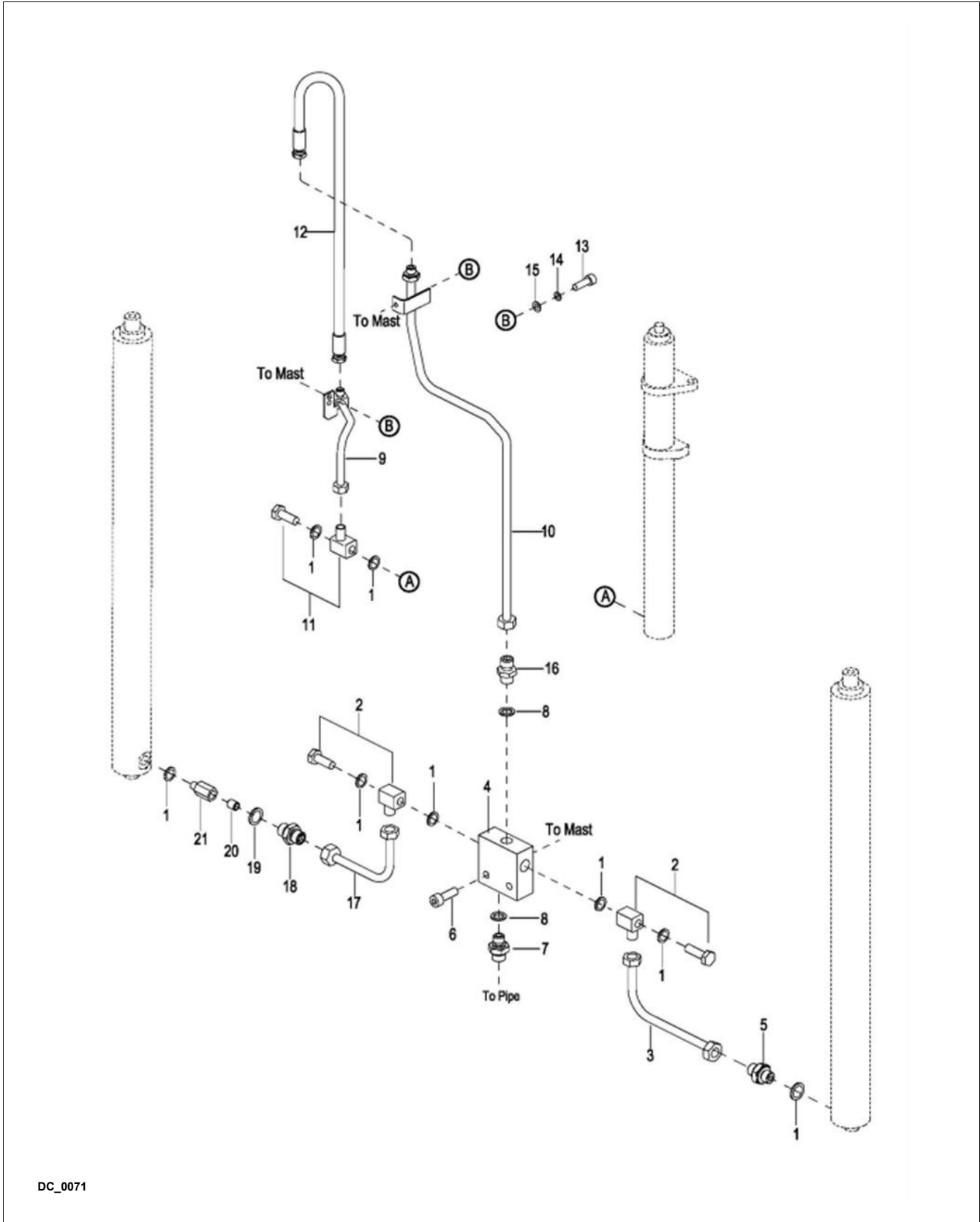

DC_0071

Figure 12-50 Hydraulic Lines (TRIMAST) - Not when side shift
Used from Serial Number 3281500027

**HYDRAULIC LINES (TRIMAST) - NOT WHEN SIDE SHIFT OPTION
(USED FROM SERIAL NUMBER 3281500027)**

Pos.	Part Number	Description	Qty. Reqd.	Notes
1	0000-000069-00	WASHER Ø16	8	
2	2706-161600-00	CONNECTORM16×1.5-M16×1.5	2	
3	2130-430000-30	METALLIC OIL PIPE	1	
4	2125-400002-30	BLOCK CROSS	1	
5	2701-161600-00	CONNECTOR M16X1.5-M16X1.5	1	
6	0000-000169-00	SCREW M8×30	2	
7	2702-141600-00	CONNECTOR G1/4X1.5-M16X1.5	1	
8	0000-000044-00	WASHER Φ14	2	
9	2125-430000-3B	METALLIC OIL PIPE	1	
10	2125-450000-3A	METALLIC OIL PIPE ASSEMBLY ?	1	
11	2706-162000-10	CONNECTOR M16×1.5-M20×1.5	1	
12	2125-440000-3A	METAL TUBE	1	
13	0000-000109-00	SCREW M8×16	3	
14	0000-000159-00	LOCK WASHER Φ8	3	
15	0000-000176-00	FLAT WASHER Φ8	3	
16	2702-142000-00	CONNECTOR G1/4-M20×1.5	1	
17	2130-431000-R0	METALLIC PIPE ASSEMBLY	1	
18	2702-381600-10	CONNECTOR G3/8-M16×1.5	1	
19	0000-000634-00	WASHER Ø18	1	
20	2214-431000-R0	EXPLOSION RELIEF VALVE	1	
21	CK10-400001-3B	CONNECTOR M16×1.5-G3/8	1	

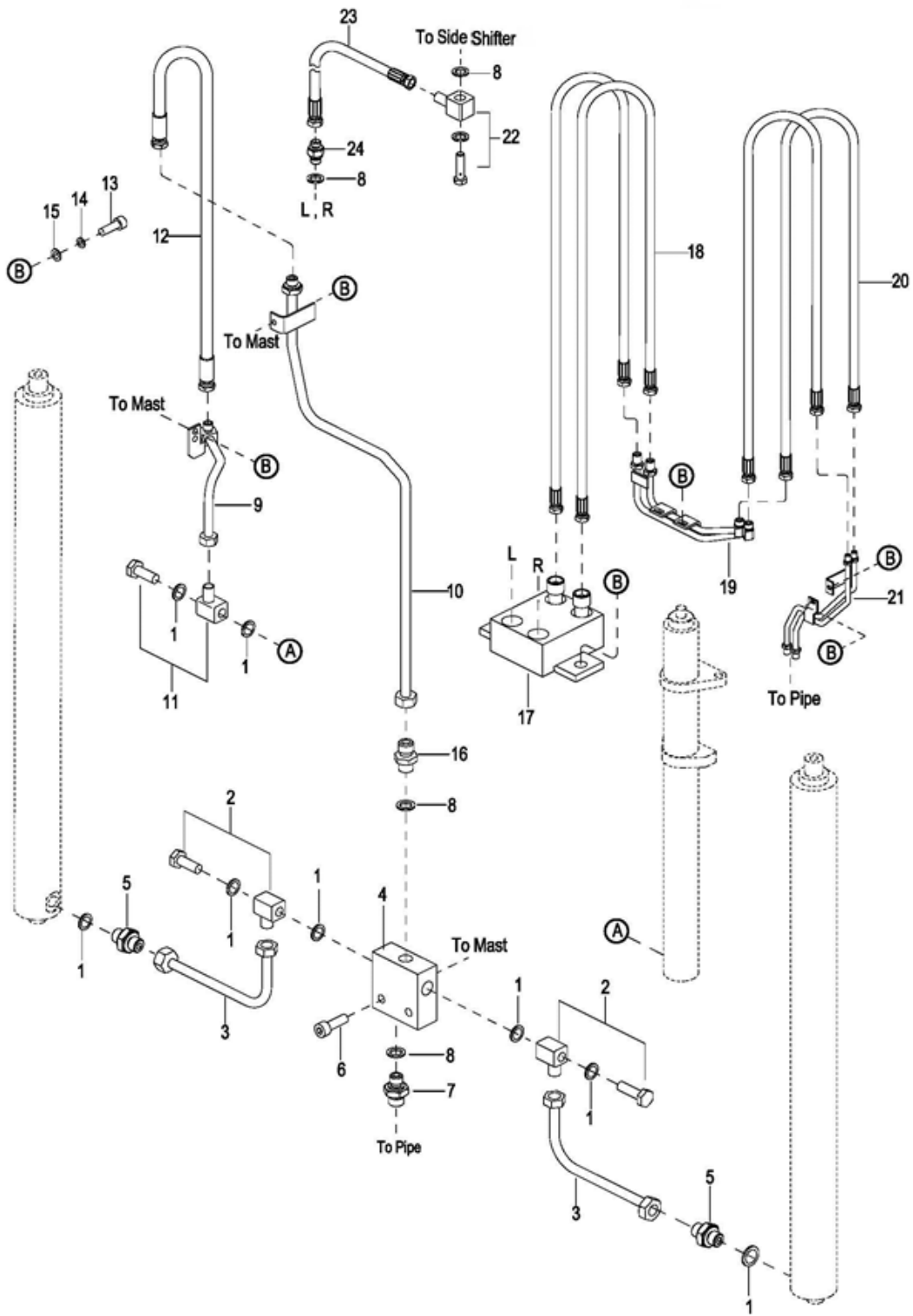

R8066

Figure 12-51 Hydraulic Lines (TRIMAST) - Used up to serial number 3281500026
When side shift option

**HYDRAULIC LINES (TRIMAST) - USED UP TO SERIAL NUMBER 3281500026
WHEN SIDE SHIFT OPTION**

Pos.	Part Number	Description	Qty. Reqd.	Notes
1	0000-000069-00	WASHER Ø16	8	
2	2706-161600-00	CONNECTOR M16×1.5-M16×1.5	2	
3	2130-430000-30	METALLIC PIPE ASSEMBLY	2	
4	2125-400002-30	VALVE BLOCK	1	
5	2701-161600-00	CONNECTOR M16×1.5-M16×1.5	2	
6	0000-000169-00	SCREW M8×30	2	
7	2702-141600-00	CONNECTOR G1/4-M16×1.5	1	
8	0000-000044-00	WASHER Ø14	8	
9	2125-430000-3B	METALLIC OIL PIPE ASSEMBLY	1	
10	2125-450000-3A	METALLIC OIL PIPE ASSEMBLY ?	1	
11	2706-162000-10	CONNECTOR M16×1.5-M20×1.5	1	
12	2125-440000-3A-01	HOSE	1	Used for lift height 157" - TRIMAST
12a	2125-440000-3A-02	HOSE	1	Used for lift height 177" - TRIMAST
13	0000-000109-00	SCREW M8×16	9	
14	0000-000159-00	LOCKWASHER Ø8	9	
15	0000-000176-00	FLATWASHER Ø8	9	
16	2702-142000-00	CONNECTOR G1/4-M20×1.5	1	
17	3215-860100-30	FOUR WAY VALVE	1	
18	2130-440000-40-01	OIL PIPE	2	Used for lift height 157" - TRIMAST
18a	2130-440000-40-02	OIL PIPE	2	Used for lift height 177" - TRIMAST
19	3215-860200-30	METAL TUBE	1	
20	2130-450000-40-01	OIL PIPE	2	Used for lift height 157" - TRIMAST
20a	2130-450000-40-02	OIL PIPE	2	Used for lift height 177" - TRIMAST
21	3215-860500-30	METAL TUBE	1	
22	2706-141400-00	CONNECTOR M14×1.5-M14×1.5	2	
23	2130-430000-40	OIL PIPE	2	
24	2701-141400-00	CONNECTOR M14×1.5-M14×1.5	2	

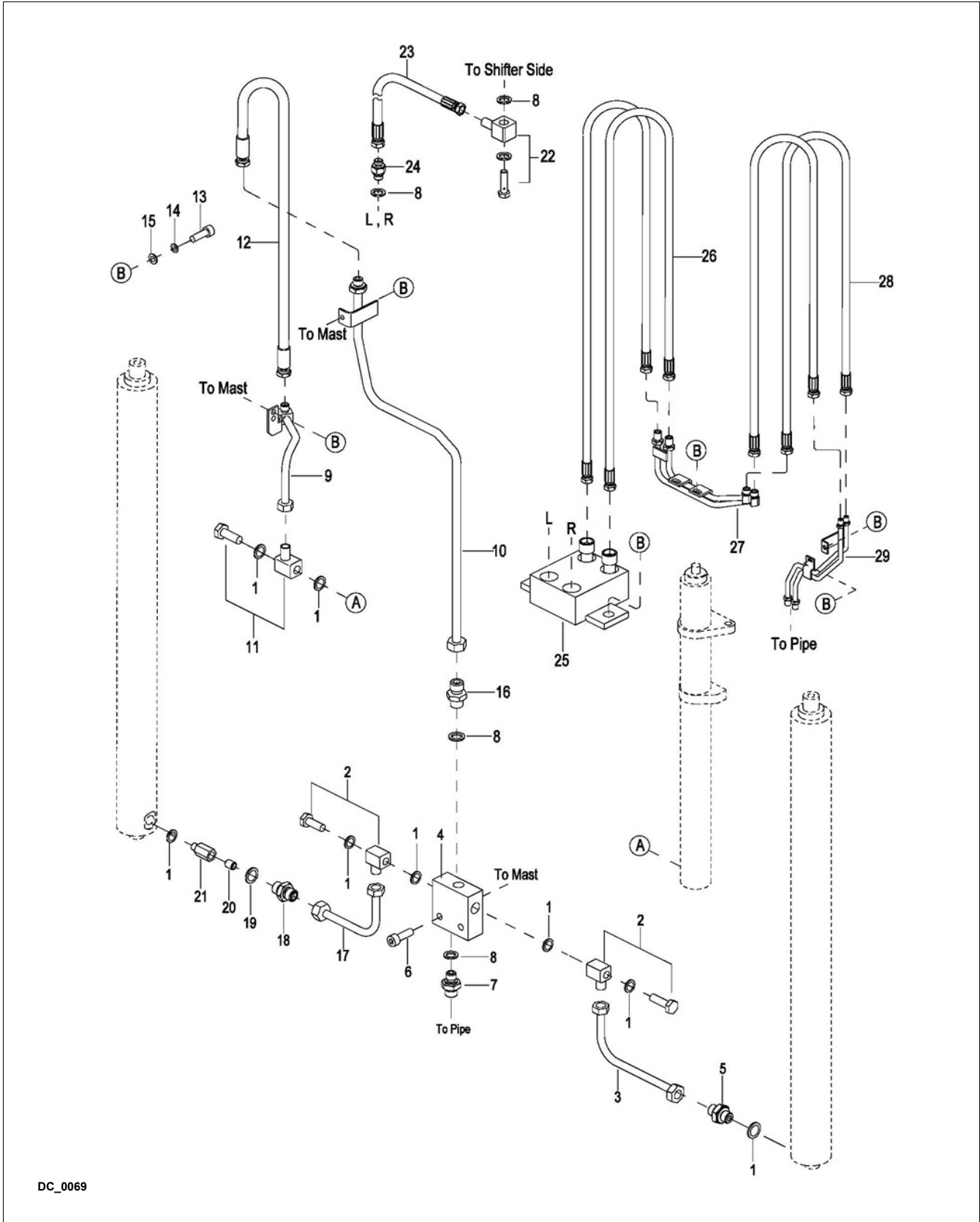

DC_0069

Figure 12-52 Hydraulic Lines (TRIMAST) - Used from serial number 328150027
Used when side shift option

**HYDRAULIC LINES (TRIMAST) - USED FROM SERIAL NUMBER 3281500027
USED WHEN SIDE SHIFT OPTION**

Pos.	Part Number	Description	Qty. Reqd.	Notes
1	0000-000069-00	WASHER Ø16	8	
2	2706-161600-00	CONNECTOR M16×1.5-M16×1.5	2	
3	2130-430000-30	METALLIC PIPE ASSEMBLY	1	
4	2125-400002-30	VALVE BLOCK	1	
5	2701-161600-00	CONNECTOR M16×1.5-M16×1.5	1	
6	0000-000169-00	SCREW M8×30	2	
7	2702-141600-00	CONNECTOR G1/4-M16×1.5	1	
8	0000-000044-00	WASHER Ø14	8	
9	2125-430000-3B	METALLIC OIL PIPE ASSEMBLY	1	
10	2125-450000-3A	METALLIC OIL PIPE ASSEMBLY ?	1	
11	2706-162000-10	CONNECTOR M16×1.5-M20×1.5	1	
12	2125-440000-3A-01	HOSE	1	Used for lift height 157" - TRIMAST
12a	2125-440000-3A-02	HOSE	1	Used for lift height 177" - TRIMAST
13	0000-000109-00	SCREW M8×16	9	
14	0000-000159-00	LOCKWASHER Ø8	9	
15	0000-000176-00	FLATWASHER Ø8	9	
16	2702-142000-00	CONNECTOR G1/4-M20×1.5	1	
17	2130-431000-R0	METALLIC PIPE ASSEMBLY	1	
18	2702-381600-10	CONNECTOR G3/8-M16×1.5	1	
19	0000-000634-00	WASHER Ø18	1	
20	2214-431000-R0	EXPLOSION RELIEF VALVE	1	
21	CK10-400001-3B	CONNECTOR M16×1.5-G3/8	1	
22	2706-141400-00	CONNECTOR M14×1.5-M14×1.5	2	
23	2130-430000-40	OIL PIPE	2	
24	2701-141400-00	UNION M14X1.5-M14X1.5	2	
25	3215-860100-30	FOUR WAY VALVE	1	
26	2130-440000-40-01	OIL PIPE	2	
26a	2130-440000-40-02	OIL PIPE	2	
27	3215-860200-30	METAL TUBE	1	
28	2130-450000-40-01	OIL PIPE	2	
28a	2130-450000-40-02	OIL PIPE	2	
29	3215-860500-30	METAL TUBE	1	

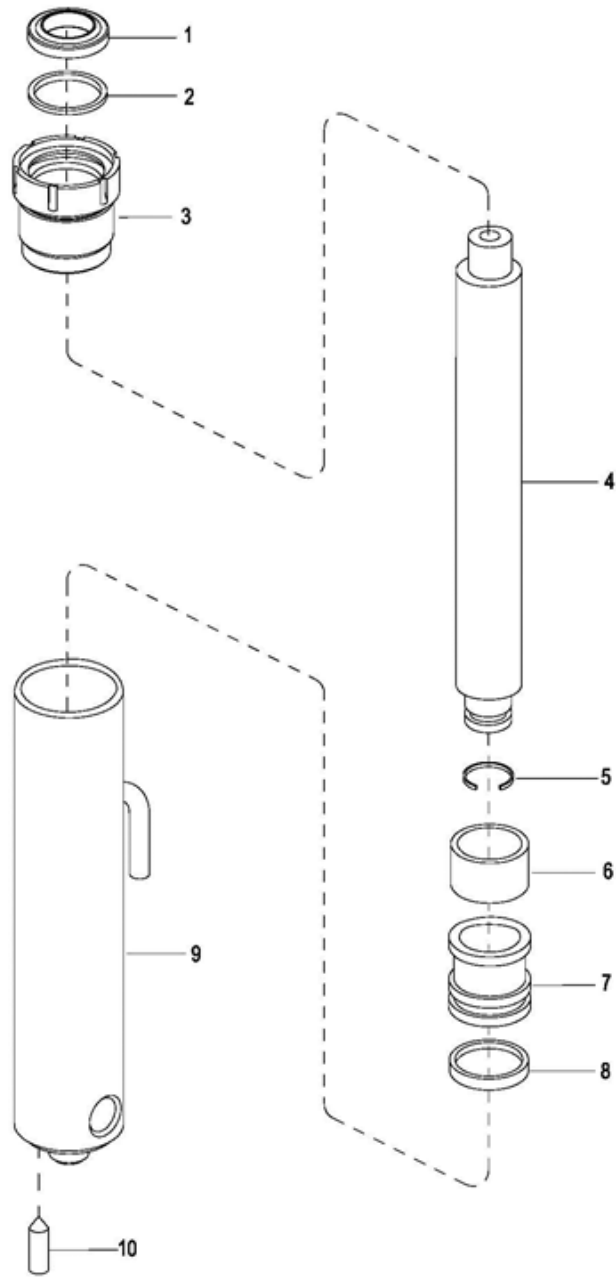

R6825

Figure 12-53 Lift Cylinder (Telescopic)

LIFT CYLINDER (TELESCOPIC)

Pos.	Part Number	Description	Qty. Reqd.	Notes
--	2130-410000-00-01	LIFT CYLINDER ASSEMBLY	1	Used for lift height 104" - Telescopic
--	2130-410000-00-02	LIFT CYLINDER ASSEMBLY	1	Used for lift height 126" - Telescopic
--	2130-410000-00-03	LIFT CYLINDER ASSEMBLY	1	Used for lift height 142" - Telescopic
KIT	2130-2BG	SEAL KIT FOR LIFT CYLINDER	1	Incl. Pos. # 1, 2 & 8
1	0000-000084-00	RING WIPER 35×43×5-6.5	1	
2	0000-000370-00	O-RING 40×3.1	1	
3	1220-420001-0A	CAP	1	
4	2130-410001-00-01	PISTON ROD	1	Used for lift height 104" - Telescopic
4a	2130-410001-00-02	PISTON ROD	1	Used for lift height 126" - Telescopic
4b	2130-410001-00-03	PISTON ROD	1	Used for lift height 142" - Telescopic
5	2130-410003-00	COLLAR	1	
6	2130-410004-00	RING BACK UP	1	
7	2130-410002-00	PISTON	1	
8	0000-000132-00	ROD PACKING 30×40×6	1	
9	2130-411000-00-01	CYLINDER TUBE	1	Used for lift height 104" - Telescopic
9a	2130-411000-00-02	CYLINDER TUBE	1	Used for lift height 126" - Telescopic
9b	2130-411000-00-03	CYLINDER TUBE	1	Used for lift height 142" - Telescopic
10	2125-410006-30	PIN	1	

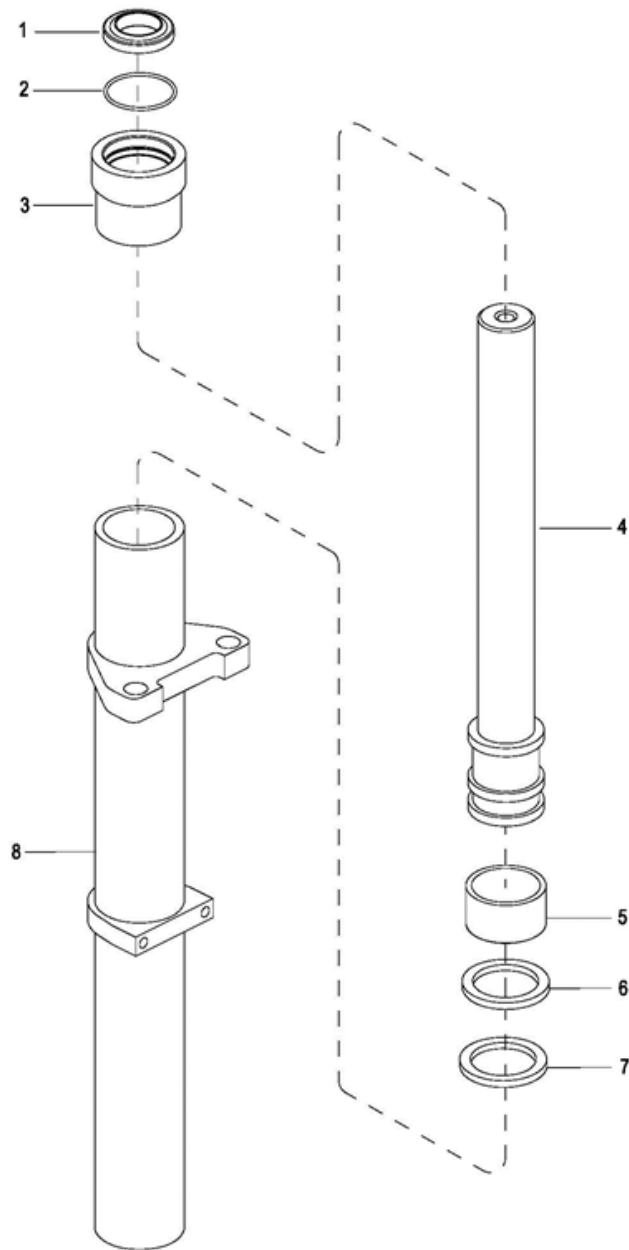

R6826

Figure 12-54 Free Lift Cylinder (TRIMAST)

FREE LIFT CYLINDER (TRIMAST)

Pos.	Part Number	Description	Qty. Reqd.	Notes
--	2130-420000-30-01	LIFT CYLINDER ASSEMBLY	1	Used for lift height 157" - TRIMAST
--	2130-420000-30-02	LIFT CYLINDER ASSEMBLY	1	Used for lift height 177" - TRIMAST
KIT	2130-3ZG	SEAL KIT	1	Inc. pos. # 1, 2 & 7
1	0000-000045-00	RING WIPER 55×63×5-6.5	1	
2	0000-000690-00	O-RING 60×3.1	1	
3	2130-420002-30	CAP	1	
4	2130-420001-30-01	PISTON ROD	1	Used for lift height 157" - TRIMAST
4a	2130-420001-30-02	PISTON ROD	1	Used for lift height 177" - TRIMAST
5	2130-420003-30	RING BACK UP 70×65×20	1	
6	0000-000698-00	SNAP RING 53×63×2	1	
7	0000-000699-00	COLLAR 53×63×6	1	
8	2130-421000-30-01	CYLINDER TUBE	1	Used for lift height 157" - TRIMAST
8a	2130-421000-30-02	CYLINDER TUBE	1	Used for lift height 177" - TRIMAST

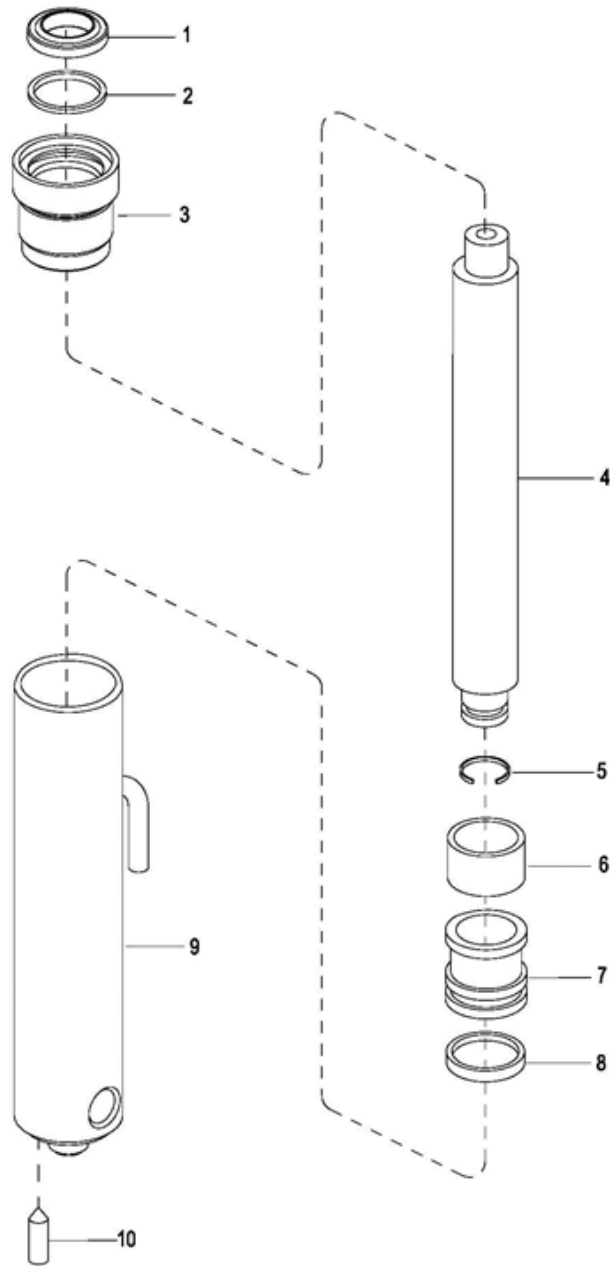

R6827

Figure 12-55 Secondary Lift Cylinder (TRIMAST)

SECONDARY LIFT CYLINDER (TRIMAST)

Pos.	Part Number	Description	Qty. Reqd.	Notes
--	2130-410000-30-01	LIFT CYLINDER ASSEMBLY	1	Used for lift height 157" - TRIMAST (2 per truck)
--	2130-410000-30-02	LIFT CYLINDER ASSEMBLY	1	Used for lift height 177" - TRIMAST (2 per truck)
KIT	2130-3BG	SEAL KIT FOR LIFT CYLINDER	1	Incl. pos. # 1, 2 & 8
1	0000-000084-00	RING WIPER 35×43×5-6.5	1	
2	0000-000370-00	O-RING 40×3.1	1	
3	1220-420001-0A	CAP	1	
4	2130-410001-30-01	PISTON ROD	1	Used for lift height 157" - TRIMAST
4a	2130-410001-30-02	PISTON ROD	1	Used for lift height 177" - TRIMAST
5	2130-410003-30	COLLAR	1	
6	2130-410004-30	RING BACK UP	1	
7	2130-410002-30	PISTON	1	
8	0000-000132-00	ROD PACKING	1	
9	2130-411000-30-01	CYLINDER TUBE	1	Used for lift height 157" - TRIMAST
9a	2130-411000-30-02	CYLINDER TUBE	1	Used for lift height 177" - TRIMAST
10	2125-410006-30	PIN	1	

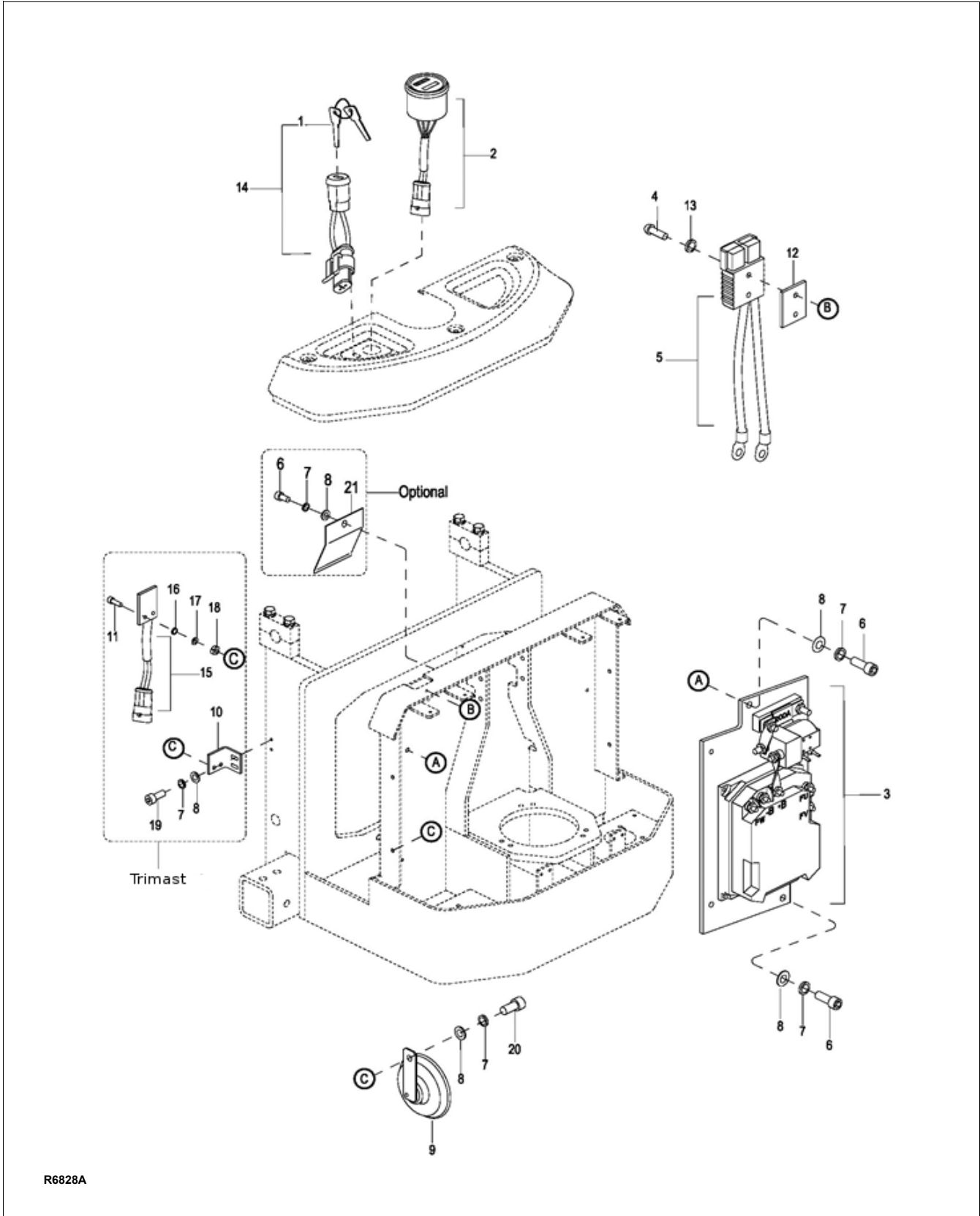

R6828A

Figure 12-56 Electrical System - Used up to serial number S2112138

ELECTRICAL SYSTEM USED UP TO SERIAL NUMBER S2112138

Pos.	Part Number	Description	Qty. Reqd.	Notes
1	1120-500016-00	KEY	1	
2	1220-520007-0C	BDI ASSEMBLY WITH HOUR METER (SEE NOTE)	1	3 Pin Assembly BDI not sold separately
3	See Electrical Panel Sec.	CONTROL BOARD ASSEMBLY	1	
4	0000-000498-00	SCREW M6×30	2	
5	2130-531000-00	CONNECTOR BATTERY ASSEMBLY	1	
6	0000-000321-00	SCREW M8×20	2	
7	0000-000159-00	LOCKWASHER Ø8	5	
8	0000-000194-00	FLATWASHER Ø8	5	
9	1120-500003-00	HORN	1	
10	2114-500001-00	SENSOR BRACKET	1	
11	0000-000378-00	SCREW M4×16	2	
12	1120-112008-00	PLATE	1	
13	0000-000056-00	LOCKWASHER Ø6	2	
14	1220-520002-0C	2 WAY SWITCH ASSEMBLY	1	
15	2130-520003-30	PROXIMITY SWITCHES WIRING	1	Used on TRIMAST
16	0000-000122-00	LOCKWASHER Ø4	2	
17	0000-000702-00	FLATWASHER Ø4	2	
18	0000-000139-00	NUT M4	2	
19	0000-000109-00	SCREW M8×16	2	
20	0000-000433-00	SCREW M8×12	1	
21	1120-100003-00	BATTERY CLIP	1	

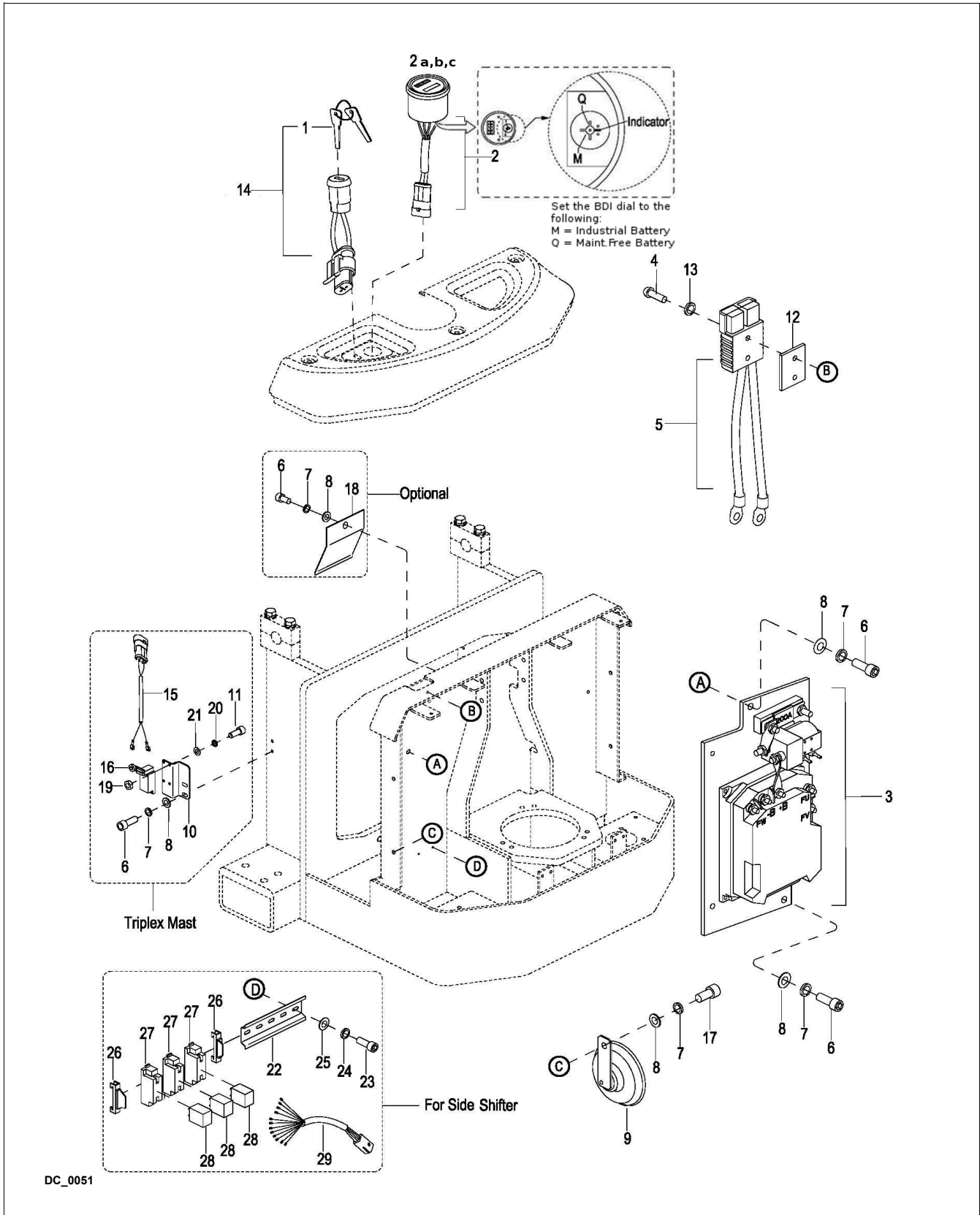

Figure 12-57 Electrical System - Used between serial number S2112139 - 324170029

ELECTRICAL SYSTEM USED BETWEEN SERIAL NUMBER S2112139 - 324170029

Pos.	Part Number	Description	Qty. Reqd.	Notes
1	1120-500016-10	KEY	1	
2	1220-520007-0D	BDI WIRE HARNESS	1	Used from 04-15-2012:
2a	1220-520007-0C	BDI ASSEMBLY WITH HOUR METER (SEE NOTE)	1	3 Pin Assembly BDI not sold separately - Used up to 04-14-2012
2b	1115-510006-2B-01	BATTERY INDICATOR (BDI) WITH HOUR METER	1	Used from 04-15-2012: Set the BDI dial to the following: M = Industrial Battery
2c	1115-510006-2B-02	BATTERY INDICATOR (BDI) WITH HOUR METER	1	Used from 04-15-2012: Set the BDI dial to the following: Q = Maint.Free Battery
3	--	CONTROL BOARD ASSEMBLY	1	See Electrical Panel Section
4	0000-000498-00	SCREW M6×30	2	
5	2130-531000-00	CONNECTOR BATTERY ASSEMBLY	1	
6	0000-000321-00	SCREW M8×20	5	
7	0000-000159-00	LOCKWASHER Ø8	6	Used on TRIMAST
8	0000-000194-00	FLATWASHER Ø8	6	Used on TRIMAST
9	1120-500003-00	HORN	1	
10	2125-500001-3A	SENSOR BRACKET	1	Used on TRIMAST
11	0000-000518-00	SCREW M5×8	4	Used on TRIMAST
12	1120-112008-00	PLATE	1	
13	0000-000056-00	LOCKWASHER Ø6	2	
14	1220-520002-1C	2 WAY SWITCH ASSEMBLY	1	Used from serial number S2119007
15	2130-520003-3A	PROXIMITY SWITCH WIRING	1	Used on TRIMAST
16	2125-500003-00	PROXIMITY SWITCH 8108	1	Used on TRIMAST
17	0000-000433-00	SCREW M8×12	1	
18	1120-100003-00	BATTERY CLIP	1	
19	0000-000546-00	NUT M5	4	
20	0000-000206-00	LOCKWASHER Ø5	4	Used on TRIMAST
21	0000-000390-00	FLATWASHER Ø5	4	Used on TRIMAST
22	2110-500002-00	RELAY BRACKET	1	Used when side shift option
23	0000-000009-00	SCREW M4×12	2	Used when side shift option
24	0000-000122-00	LOCKWASHER Ø4	2	Used when side shift option
25	0000-000702-00	FLATWASHER Ø4	2	Used when side shift option
26	2110-500003-00	RELAY SET CLIP	2	Used when side shift option
27	2110-500004-00	RELAY SET	3	Used when side shift option
28	2110-500005-00	RELAY	3	Used when side shift option
29	2320-520005-00	RELAY WIRE HARNESS	1	Used when side shift option

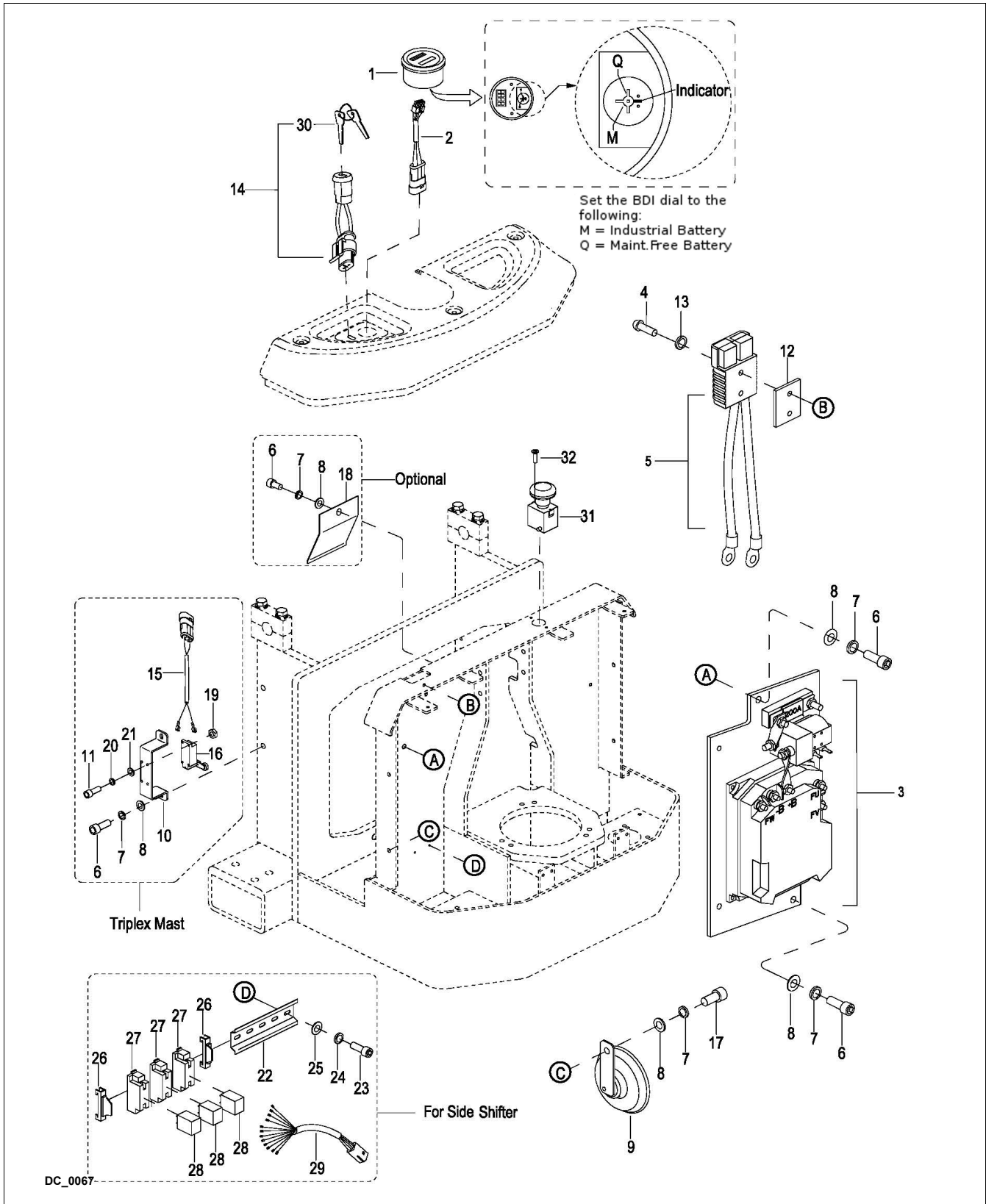
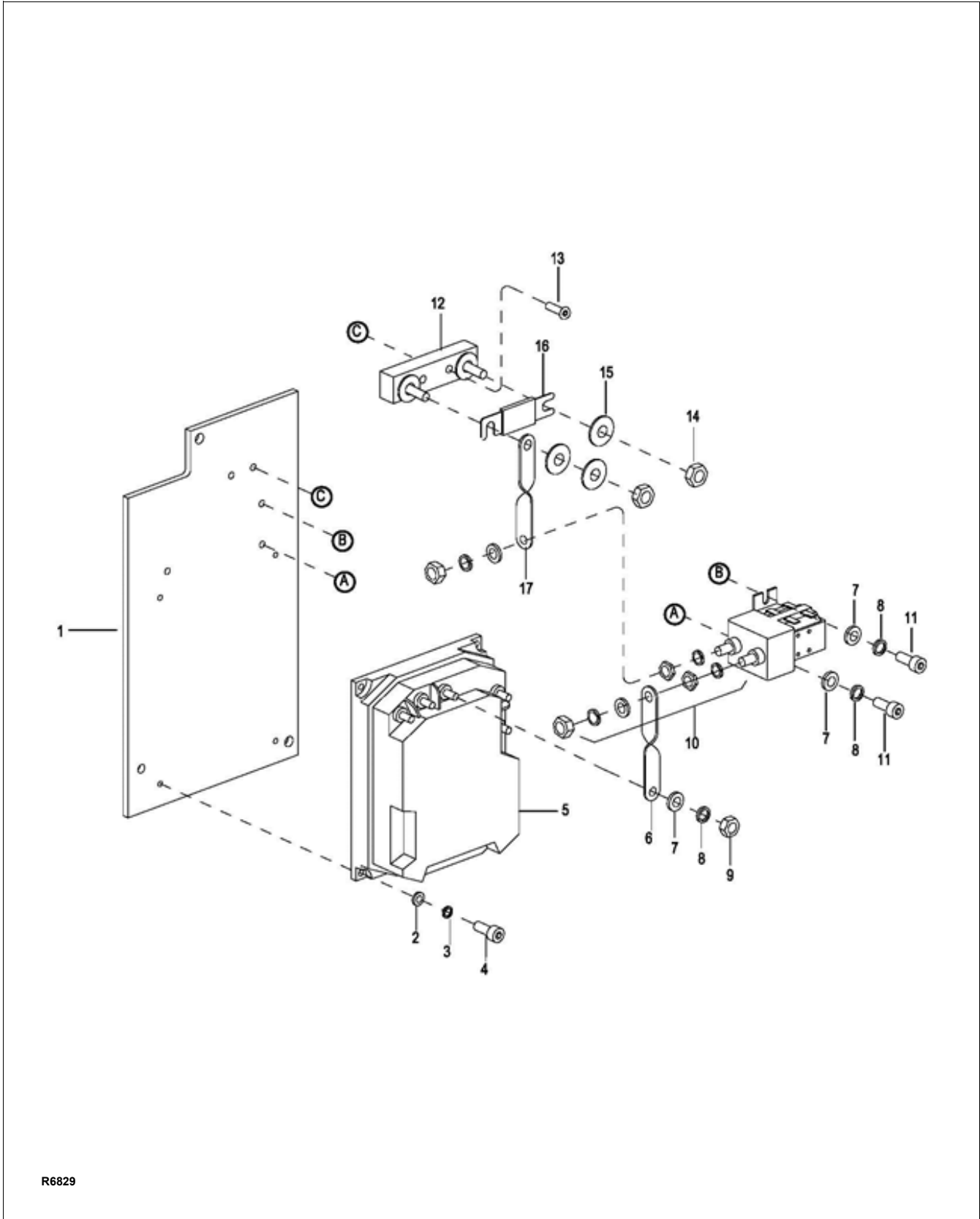

Figure 12-58 Electrical System - Used from serial number 324170030

ELECTRICAL SYSTEM USED FROM SERIAL NUMBER 324170030

Pos.	Part Number	Description	Qty. Reqd.	Notes
1	1115-510006-2B-01	BATTERY INDICATOR (BDI) WITH HOUR METER	1	Used from 04-15-2012: Set the BDI dial to the following: M = Industrial Battery
1a	1115-510006-2B-02	BATTERY INDICATOR (BDI) WITH HOUR METER	1	Used from 04-15-2012: Set the BDI dial to the following: Q = Maint.Free Battery
2	1220-520007-0D	BDI WIRE HARNESS	1	Used from 04-15-2012:
3	--	CONTROL BOARD ASSEMBLY	1	Used up to serial number 3281901818, See Elect. Panel Section
3a	2140-51000Z-00	CONTROL BOARD ASSEMBLY	1	Used from serial number 3281901819
4	0000-000498-00	SCREW M6×30	2	
5	2130-531000-00	CONNECTOR BATTERY ASSEMBLY	1	Used up to serial number 3281901818
5a	2130-531000-P0	CONNECTOR BATTERY ASSEMBLY	1	Used between serial number 3281901819 - 3291800223
5b	2130-531000-PA	CONNECTOR BATTERY ASSEMBLY	1	Used from serial number 3291800224
6	0000-000321-00	SCREW M8×20	5	
7	0000-000159-00	LOCKWASHER Ø8	6	Used on TRIMAST
8	0000-000194-00	FLATWASHER Ø8	6	Used on TRIMAST
9	1120-500003-00	HORN	1	
10	2125-500001-3A	SENSOR BRACKET	1	Used on TRIMAST up to Serial number 324170029
10a	2125-500003-30	SENSOR BRACKET	1	Used on TRIMAST from serial number 324170030
11	0000-000004-00	SCREW M5×12	4	Used on TRIMAST
12	1120-112008-00	PLATE	1	
13	0000-000056-00	LOCKWASHER Ø6	2	
14	1220-520002-1C	2 WAY SWITCH ASSEMBLY	1	Used from serial number S2119007
15	2130-520003-3A	PROXIMITY SWITCH WIRING	1	Used on TRIMAST
16	2125-500003-00	PROXIMITY SWITCH 8108	1	Used on TRIMAST
17	0000-000433-00	SCREW M8×12	1	
18	1120-100003-00	BATTERY CLIP	1	
19	0000-000546-00	NUT M5	4	
20	0000-000206-00	LOCKWASHER Ø5	4	Used on TRIMAST
21	0000-000390-00	FLATWASHER Ø5	4	Used on TRIMAST
22	2110-500002-00	RELAY BRACKET	1	Used when side shift option
23	0000-000009-00	SCREW M4×12	2	Used when side shift option
24	0000-000122-00	LOCKWASHER Ø4	2	Used when side shift option
25	0000-000702-00	FLATWASHER Ø4	2	Used when side shift option
26	2110-500003-00	RELAY SET CLIP	2	Used when side shift option
27	2110-500004-00	RELAY SET	3	Used when side shift option
28	2110-500005-00	RELAY	3	Used when side shift option
29	2320-520005-00	RELAY WIRE HARNESS	1	Used when side shift option
30	1120-500016-10	KEY	1	
31	1115-510008-00	EMERGENCY STOP SWITCH	1	
32	3020-030000-25	SCREW M5×16	1	



R6829

Figure 12-59 Electrical Panel

ELECTRICAL PANEL

Pos.	Part Number	Description	Qty. Reqd.	Notes
1	2125-510001-00	BOARD	1	Used up to serial number 3281901818
1a	2140-510001-00-AC	BOARD	1	Used from serial number 3281901819
2	0000-000128-00	FLATWASHER Ø5	4	
3	0000-000206-00	LOCKWASHER Ø5	4	
4	0000-000004-00	SCREW M5×12	4	
5	1120-500004-00-20	CONTROLLER	1	Used up to serial number 3281901818
5a	2110-500007-00-10	CONTROLLER	1	Used from serial number 3281901819
6	1120-530007-00	COPPER CONDUCTOR	1	Used up to serial number 3281901818
6a	2214-510002-PA	COPPER CONDUCTOR	1	Used from serial number 3281901819
7	0000-000123-00	FLATWASHER Ø6	7	
8	0000-000056-00	LOCKWASHER Ø6	7	
9	0000-000166-00	NUT M6	5	
10	1120-500005-10	CONTACTOR	1	
11	0000-000077-00	SCREW M6×12	2	
12	1120-540001-00-B	STAND	1	
13	0000-000077-00	SCREW M6×12	2	
14	0000-000196-00	NUT M8	2	
15	0000-000210-00	FLATWASHER Ø8	3	
16	1120-540002-00	FUSE 200A	1	Used up to serial number 3291902411
16a	3218-630002-01	FUSE 200A	1	Used from serial number 3291902412
17	1120-530006-00	COPPER CONDUCTOR	1	Used up to serial number 3281901818
17a	1120-530007-00	COPPER CONDUCTOR	1	Used from serial number 3281901819

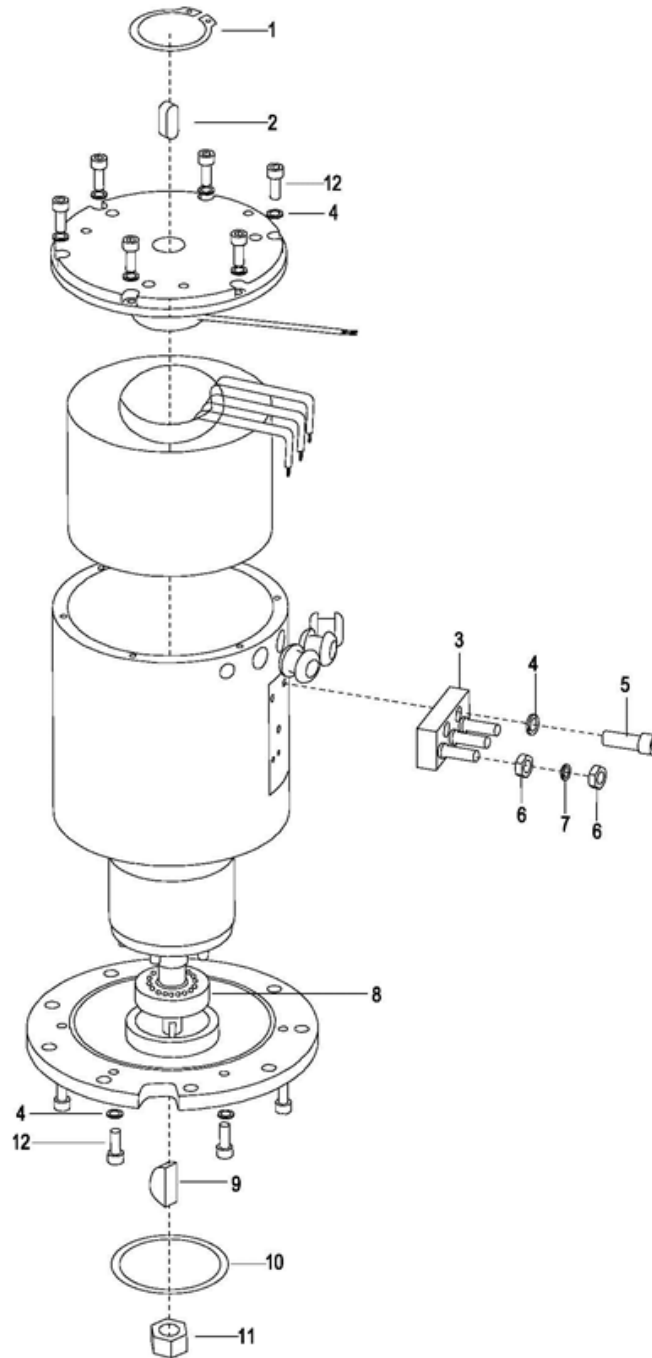

R6830

Figure 12-60 Drive Motor

DRIVE MOTOR

Pos.	Part Number	Description	Qty. Reqd.	Notes
1	0000-000293-00	RETAINING RING	2	
2	0000-000226-00	KEY 6×6×16	1	
3	1120-220001-00	TERMINAL BLOCK	1	
4	0000-000206-00	LOCKWASHER Ø5	17	
5	0000-000117-00	SCREW M5×10	2	
6	0000-000166-00	NUT M6	6	
7	0000-000056-00	LOCKWASHER Ø6	6	
8	1120-220002-00	BEARING	1	
9	0000-000204-00	KEY	1	
10	0000-000409-00	O-RING 63×3.55	1	
11	0000-000436-00	NUT M12	1	
12	0000-000323-00	SCREW M5×16	14	

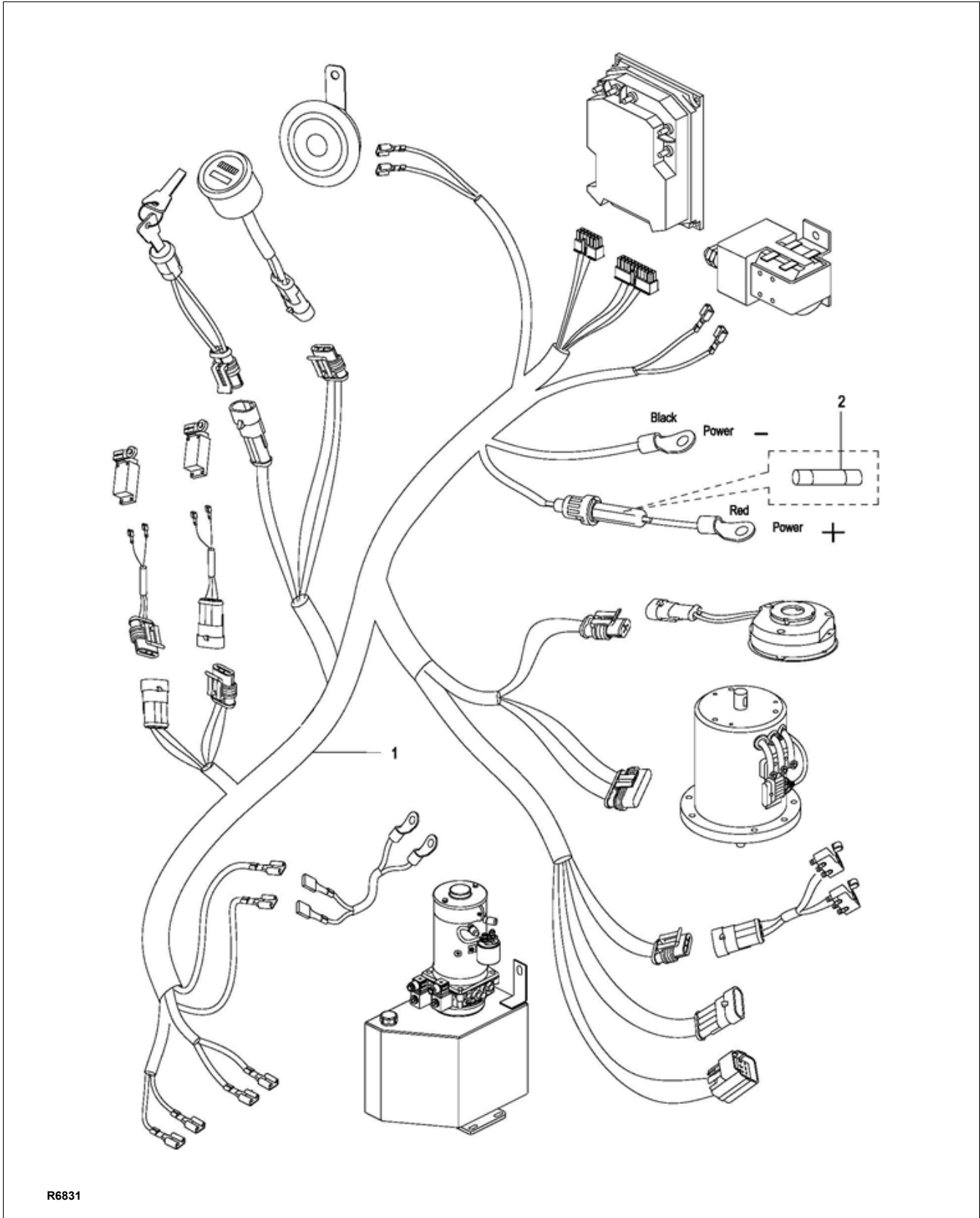

R6831

Figure 12-61 Wiring Harness - Used up to serial number 3281901818 - (Not used when Side Shift option)

**WIRING HARNESS - USED UP TO SERIAL NUMBER 3281901818
(NOT USED WHEN SIDE SHIFT OPTION)**

Pos.	Part Number	Description	Qty. Reqd.	Notes
1	2130-520001-00	WIRING HARNESS	1	
1a	1220-520014-00	WIRE	1	Not Pictured: If changing from old hydraulic unit (used up to S2117012) to new Bucher unit (used from serial number S2117013) you have to add this wire.
2	1120-500010-00	FUSE 10A	1	

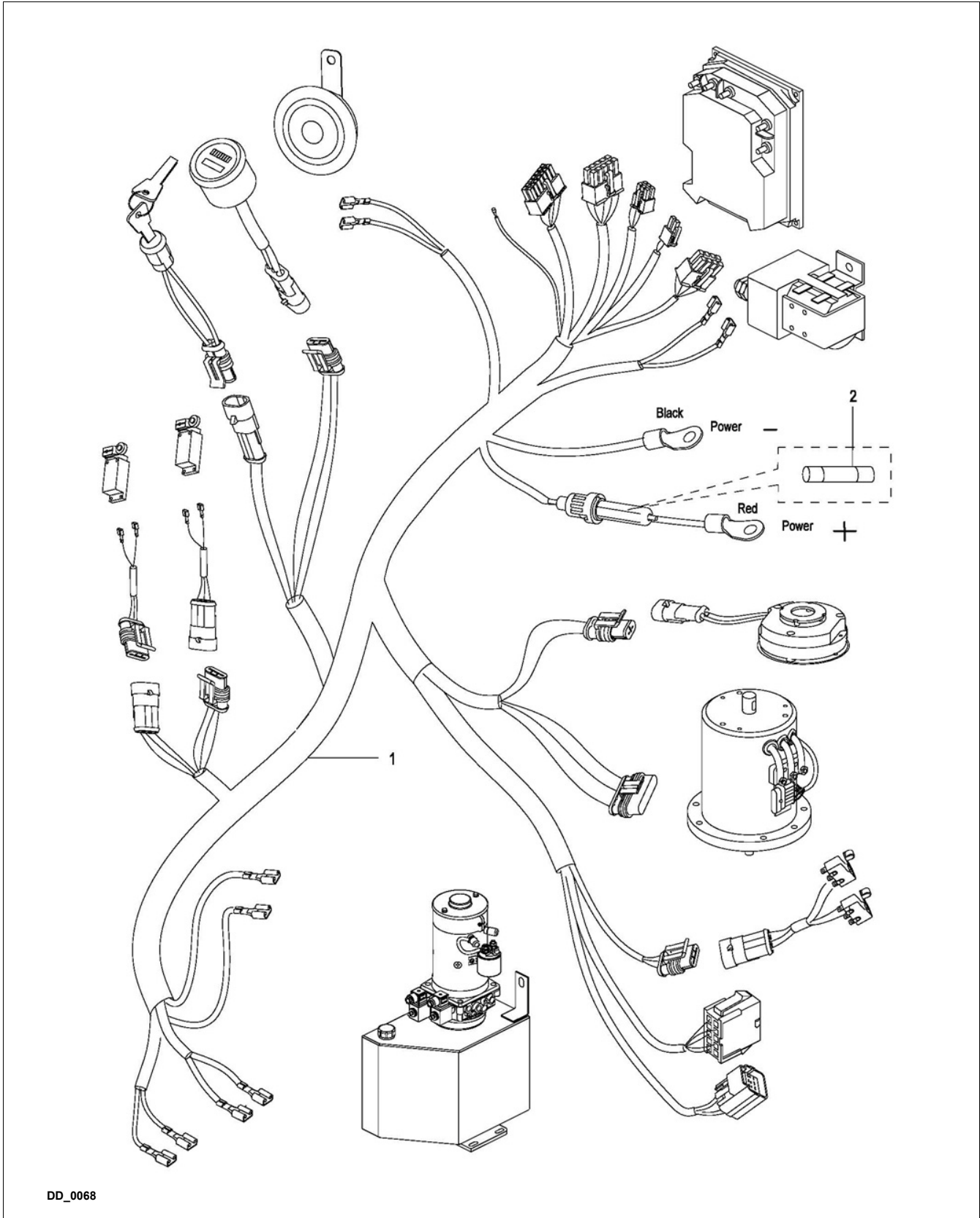
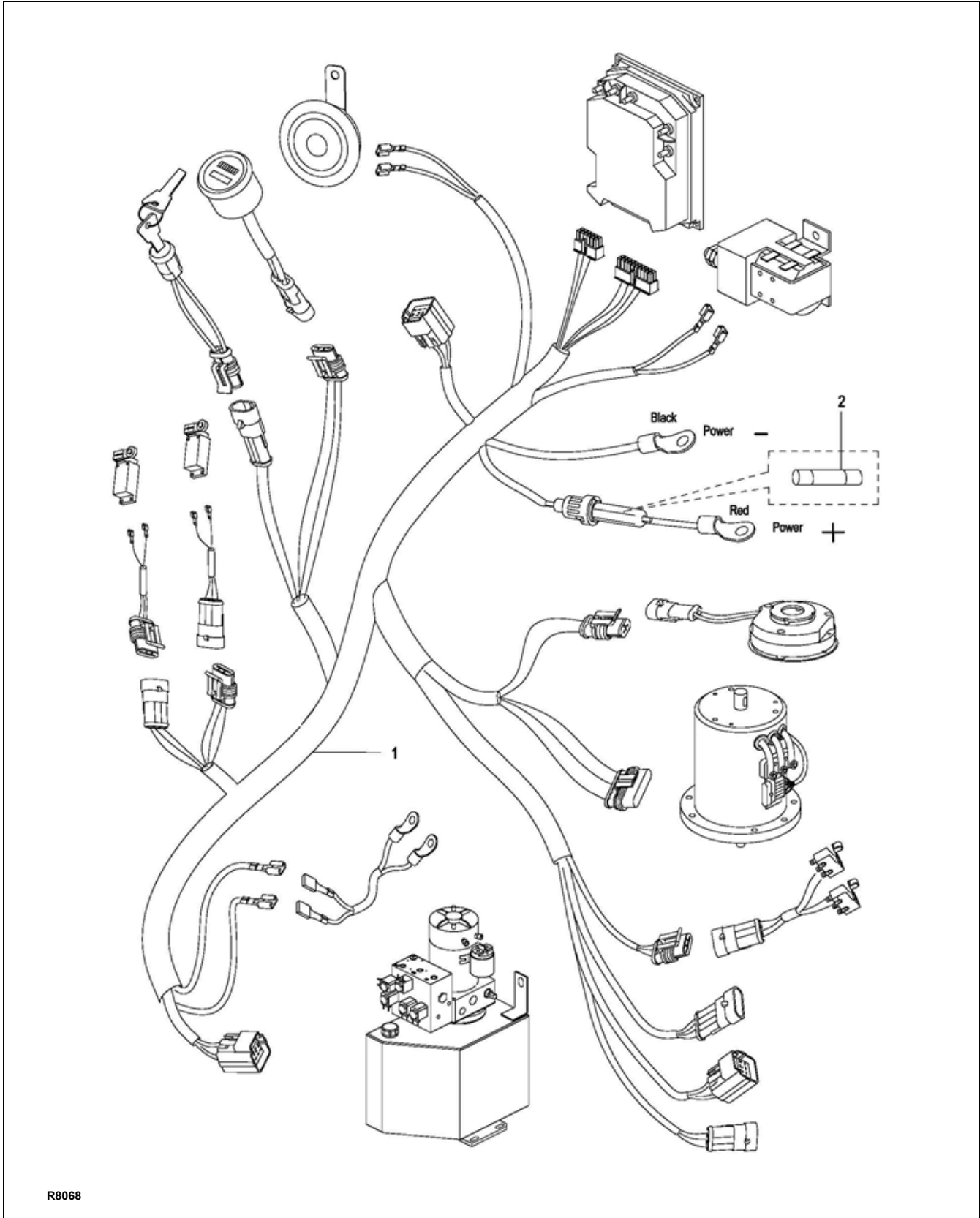

Figure 12-62 Wiring Harness - Used from serial number 3281901819 - (Not used when Side Shift option)

WIRING HARNESS - USED FROM SERIAL NUMBER 3281901819 - (NOT USED WHEN SIDE SHIFT OPTION)

Pos.	Part Number	Description	Qty. Reqd.	Notes
1	2140-520001-AC	WIRING HARNESS	1	
2	1120-500010-00	FUSE 10A	1	



R8068

Figure 12-63 Wiring Harness (Used when Side Shift option)

WIRING HARNESS (USED WHEN SIDE SHIFT OPTION)

Pos.	Part Number	Description	Qty. Reqd.	Notes
1	2130-520001-40	WIRING HARNESS	1	
1a	1220-520014-00	WIRE	1	Not Pictured: If changing from old hydraulic unit (used up to S2117012) to new Bucher unit (used from serial number S2117013) you have to add this wire.
2	1120-500010-00	FUSE 10A	1	

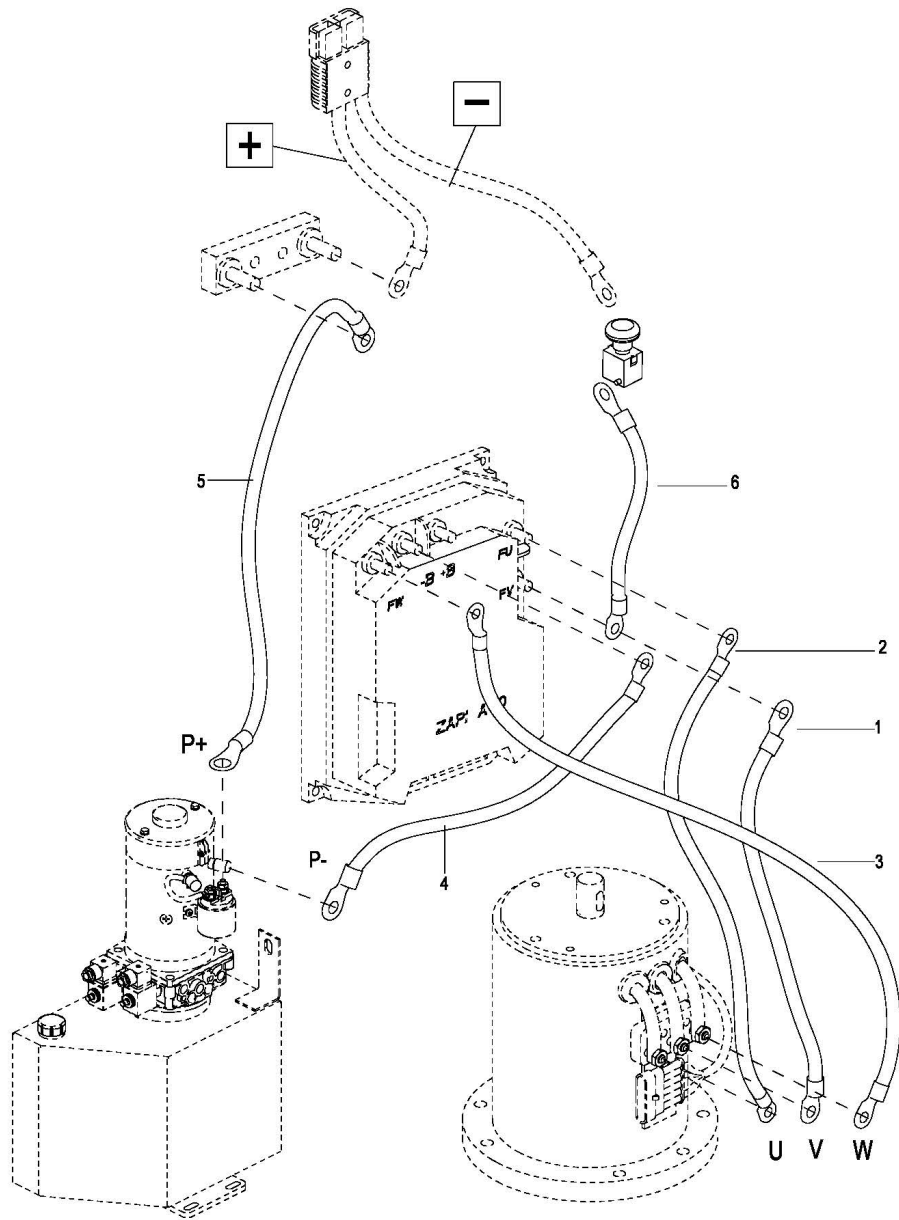

R6832

Figure 12-64 Wiring Cables

WIRING CABLES

Pos.	Part Number	Description	Qty. Reqd.	Notes
1	2130-530004-00	MOTOR LINE V	1	
2	2130-530005-00	MOTOR LINE U	1	
3	2130-530003-00	MOTOR LINE W	1	
4	2130-530007-00	PUMP POWER LINE -	1	
5	2130-530006-00	PUMP POWER LINE +	1	
6	2125-530008-00	EMERGENCY STOP SWITCH CABLE	1	

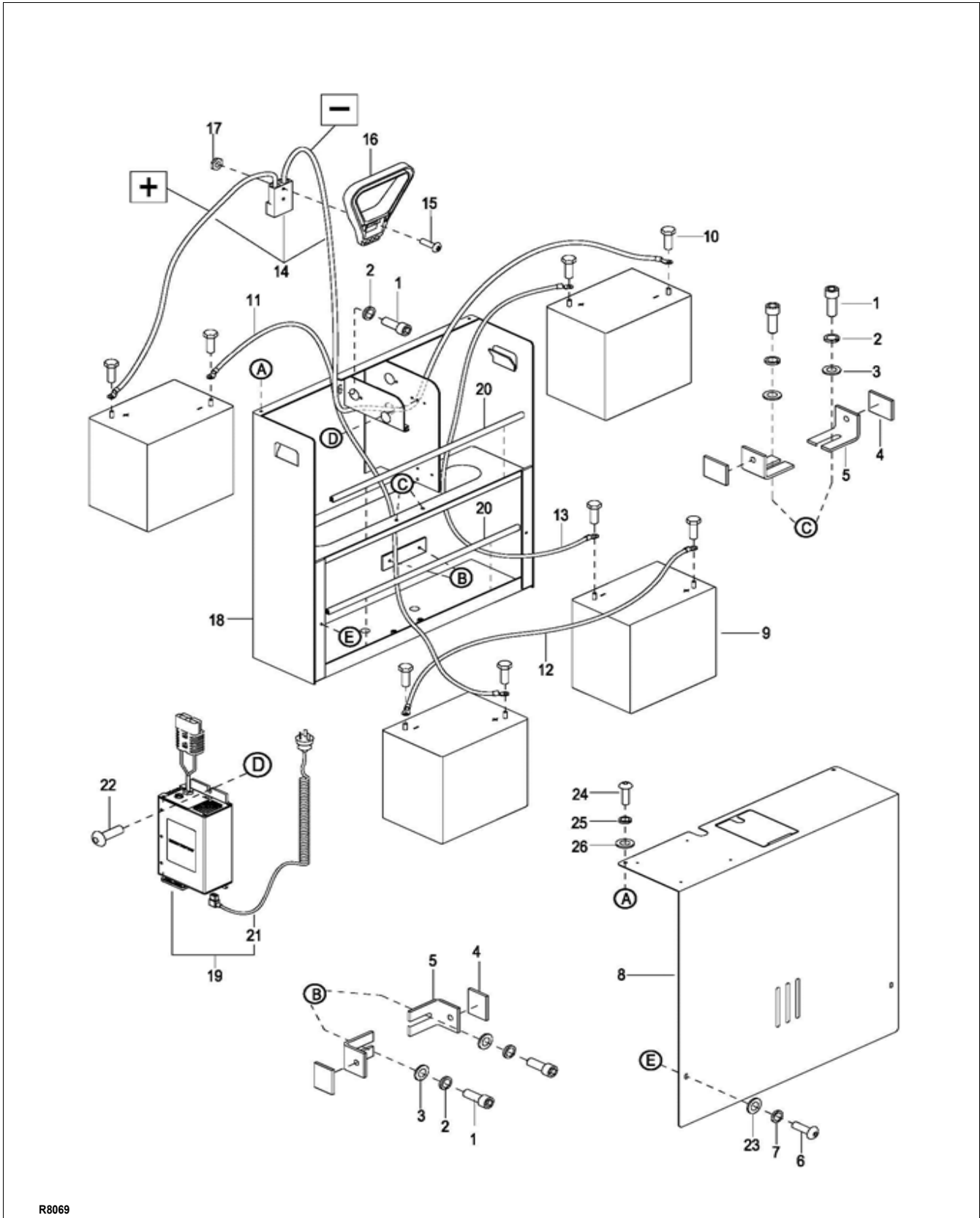

R8069

Figure 12-65 Battery Pack (Factory Installed) used up to S2410120

BATTERY PACK (FACTORY INSTALLED) USED UP TO S2410120

Pos.	Part Number	Description	Qty. Reqd.	Notes
1	0000-000055-00	SCREW M6×16	6	
2	0000-000056-00	LOCKWASHER Ø6	6	
3	0000-000380-00	FLATWASHER Ø6	4	
4	1145-550003-20	RUBBER CUSHION	4	
5	1145-550001-20	BLOCK	4	
6	0000-000119-00	SCREW M5×12	2	
7	0000-000206-00	LOCKWASHER Ø5	2	
8	1145-552000-2C	BATTERY COVER	1	Used up to serial number S2310253
8a	1145-552000-2D	BATTERY COVER	1	Used from serial number S2310254 to S2410120
9	003232	BATTERY	4	
10	0000-000550-00	NUT M8	8	Customer has to check if cables are secured with bolts or nuts
10a	0000-000242-00	BOLT M8×16	8	
11	1145-553002-2L	M2 CABLE	1	
12	1145-553001-20	M1 CABLE	1	
13	1145-553003-2L	M3 CABLE	1	
14	1145-553100-20	CONNECTOR BATTERY ASSEMBLY	1	
15	0000-000102-00	SCREW M6×45	2	
16	2125-560001-00	PULLER HANDLE	1	
17	0000-000166-00	NUT M6	2	
18	1145-551000-2C	BATTERY FRAME	1	Used up to serial number S2310253
18a	1145-551000-2D	BATTERY FRAME	1	Used from serial number S2310254 to S2410120
19	1120-560000-00	CHARGER USA 110V	1	No longer available: If replacing old charger you have to order Kit part # 1145-EP25-20, Charger 1120-560000-00-01 and Cord 1120-560002-00
20	1145-550002-20	INSERTS	2	
21	1120-560001-00	CHARGER CABLE USA 110V	1	
22	0000-000851-00	SCREW M8×12	2	
23	0000-000390-00	FLATWASHER Ø5	2	
24	0000-000119-00	SCREW M5×12	2	Used up to serial number S2310253
24a	0000-000700-00	SCREW M8×16	2	Used from serial number S2310254 to S2410120
25	0000-000206-00	LOCKWASHER Ø5	2	Used up to serial number S2310253
25a	0000-000159-00	LOCKWASHER Ø8	2	Used from serial number S2310254 to S2410120
26	0000-000176-00	FLATWASHER Ø8	2	

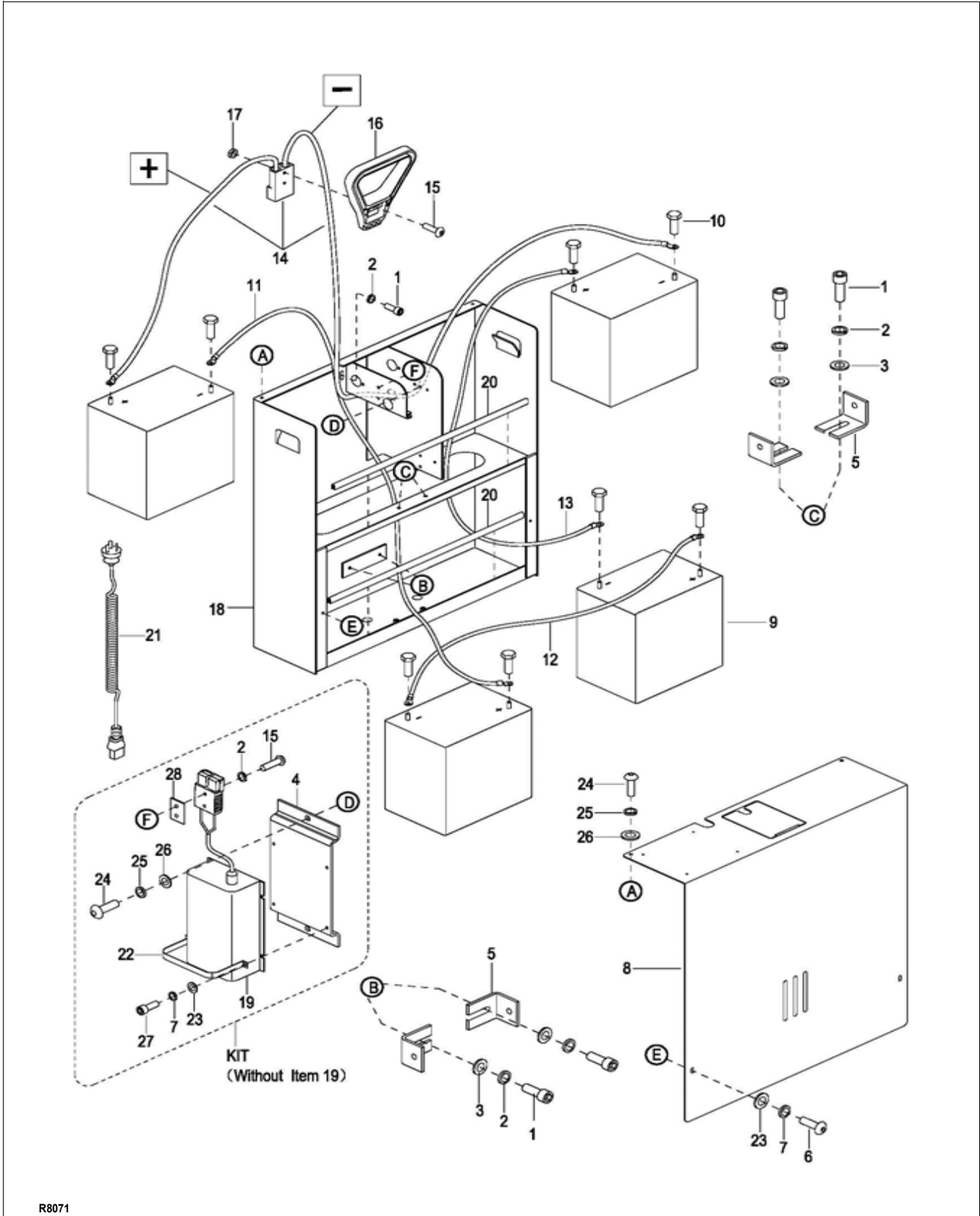

R8071

Figure 12-66 Battery Pack (Factory Installed) used from serial number S2410121 to D24140007

**BATTERY PACK (FACTORY INSTALLED)
BETWEEN SERIAL NUMBER S2410121 TO D24140007**

Pos.	Part Number	Description	Qty. Reqd.	Notes
1	0000-000055-00	SCREW M6×16	6	
2	0000-000056-00	LOCKWASHER Ø6	8	
3	0000-000380-00	FLATWASHER Ø6	4	
4	1145-550011-00	PLATE	1	
5	1145-550001-20	BLOCK	4	
6	0000-000119-00	SCREW M5×12	2	
7	0000-000206-00	LOCKWASHER Ø5	6	
8	1145-552000-2D	BATTERY COVER	1	
9	003232	BATTERY	4	
10	0000-000242-00	BOLT M8×16	8	
11	1145-553002-2L	M2 CABLE	1	
12	1145-553001-20	M1 CABLE	1	
13	1145-553003-2L	M3 CABLE	1	
14	1145-553100-20	BATTERY CONNECTOR ASSEMBLY	1	
15	0000-000498-00	SCREW M6×30	4	
16	2125-560001-00	PULLER HANDLE	1	
17	0000-000166-00	NUT M6	2	
18	1145-551000-2D	BATTERY FRAME	1	
19	1120-560000-00-01	CHARGER, 25A 110V	1	
20	1145-550002-20	INSERTION	2	
21	1120-560002-00	CHARGER CABLE 110V	1	
22	1115-500009-00	CHARGER HOOP	2	
23	0000-000390-00	FLATWASHER Ø5	6	
24	0000-000700-00	SCREW M8×16	4	
25	0000-000159-00	LOCKWASHER Ø8	4	
26	0000-000176-00	FLATWASHER Ø8	4	
27	0000-000117-00	SCREW M5×10	4	
28	1120-112008-00	PLATE	1	
KIT	1145-EP25-20	KIT FOR CHARGER INSTALLATION	1	Charger pos. # 19 is not included

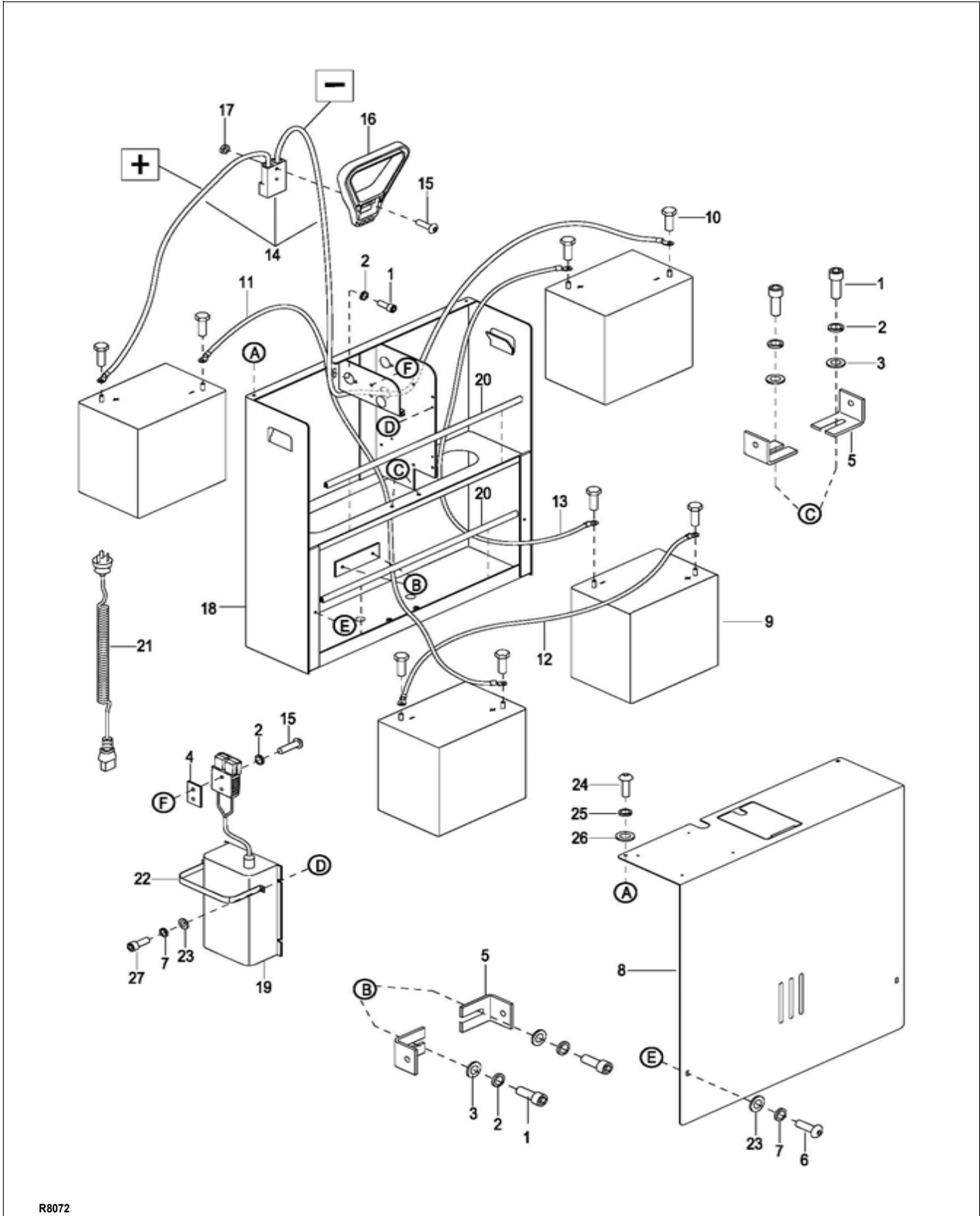

R8072

Figure 12-67 Battery Pack (Factory Installed) used from serial number D24140008

BATTERY PACK (FACTORY INSTALLED) USED FROM SERIAL NUMBER D24140008

Pos.	Part Number	Description	Qty. Reqd.	Notes
1	0000-000055-00	SCREW M6×16	6	
2	0000-000056-00	LOCKWASHER Ø6	8	
3	0000-000380-00	FLATWASHER Ø6	4	
4	1120-112008-00	PLATE	1	
5	1145-550001-20	BLOCK	4	
6	0000-000119-00	SCREW M5×12	2	
7	0000-000206-00	LOCKWASHER Ø5	6	
8	1145-552000-2D	BATTERY COVER	1	
9	003232	BATTERY	4	
10	0000-000242-00	BOLT M8×16	8	
11	1145-553002-2L	M2 CABLE	1	
12	1145-553001-20	M1 CABLE	1	
13	1145-553003-2L	M3 CABLE	1	
14	1145-553100-20	BATTERY CONNECTOR ASSEMBLY	1	
15	0000-000498-00	SCREW M6×30	4	
16	2125-560001-00	PULLER HANDLE	1	
17	0000-000166-00	NUT M6	2	
18	1145-551000-2E	BATTERY FRAME	1	
19	1120-560000-00-01	CHARGER, 25A, 110V	1	
20	1145-550002-20	INSERTION	2	
21	1120-560002-00	CHARGER CABLE USA	1	
22	1115-500009-00	CHARGER HOOP	2	
23	0000-000390-00	FLATWASHER Ø5	6	
24	0000-000700-00	SCREW M8×16	4	
25	0000-000159-00	LOCKWASHER Ø8	4	
26	0000-000176-00	FLATWASHER Ø8	4	
27	0000-000117-00	SCREW M5×10	4	



Big Lift LLC