

CONTENTS

- **Safety Information**
- **Warranty**
- **Installation Instructions**
- **Parts Diagram**

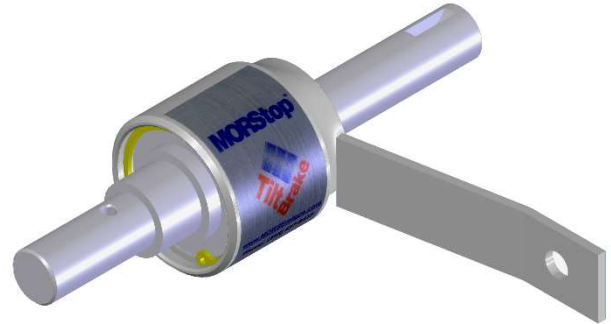

Safety Information

While Morse Manufacturing Co. drum handling equipment is engineered for safety and efficiency, a high degree of responsibility must be placed upon the machine operator to follow safe practices, based primarily on common sense, upon which true safety depends.

Failure to follow the safety precautions in this manual can result in personal injury or property damage. Observe the same precautions as with similar machinery where carelessness in operating or maintenance is hazardous to personnel. Carefully read the safety precautions below and throughout this manual.

Review the Material Safety Data Sheet(s) for the material(s) in the drum(s) and take all necessary precautions. Safety shoes, work gloves, hard hat and other personal protective devices are recommended.

Prior to initial use, inspect all moving parts. Perform necessary load test, inspections, operator training, etc.

Limited Warranty

MORSE DRUM HANDLING EQUIPMENT is guaranteed against defects in workmanship or materials, when used properly within its rated capacity, for two years. Motors and other purchased parts carry the warranty of their manufacturers.

For Warranty claims, call or write for authorization to return the product prepaid, stating defect. (No return will be accepted without proper authorization.) In all instances, liability is limited to the purchase price paid and liability under the above stated warranty is limited to repairing or replacing any product which upon our examination is found to be defective.

IMPORTANT - Before installing MORStop™ Tilt-Brake, please read the following:

1. Remove drum and be sure it is safe to work on the gearing before proceeding.
2. Remove gear covers, if applicable.
3. Using needle nose pliers carefully remove the spring clip (item 11), side link (item 10) and master link (item 8) on the #35 pitch roller chain (item 9).
4. Remove the drive sprocket (item 3 or 5) from the gear block in one of the following ways:
 - a. If sprocket is welded to the shaft (item 3): using a 3/16" punch and hammer, carefully press out the roll pin (not shown) and slide the drive sprocket with shaft and spacer (item 4) out of the gear block. You will no longer use these parts.
 - b. If sprocket is set screwed onto the shaft (item 5): loosen sprocket setscrews, remove sprocket from shaft, remove the woodruff key (item 6), finally, prior to sliding crank device from gear block, file shaft around keyway to prevent bearing damage.
5. On some Morse drum handlers, i.e. Morse model 285A, the weld between the gear block and 2 x 3 vertical leg tube may interfere with the MORStop™ (see Figure 1). This weld will need to be ground enough to clear the MORStop™.
6. Before MORStop™ installation, ensure that the outer surface of the bronze bearing is clean and free from paint. Lightly sand if necessary.



WARNING - This product can expose you to chemicals including barium sulfate, cobalt, titanium dioxide, and 2-methylimidazole, which are known to the State of California to cause cancer, and bisphenol-A, which is known to the State of California to cause birth defects or other reproductive harm. For more information go to www.P65Warnings.ca.gov

INSTALLATION

1. Insert the keyway end of the shaft on the MORStop™ Tilt-Brake assembly (item 13) into the bearing where the crank device was removed in step 4 above. Turn the MORStop™ assembly while pushing into the bearing until the torque arm (the tab with the hole) rests against the gear block.

Note: The MORStop™ assembly must be bolted in place to work properly. If your Morse drum handler was manufactured before 08/1995 (s/n 0895) and does not have the bolt hole noted in the diagram, the gear block must be drilled, and you should proceed to step 1 a. Otherwise proceed to step 2.

 - a. Turn the torque arm until the bolt hole is centered on gear block. Mark gear block where the hole is to be drilled.
 - b. With the MORStop™ assembly removed, drill a 3/16 pilot hole through the gear block.
 - c. With a 7/16" drill, drill out to finished hole size.
2. Re-insert the MORStop™ into the bearing and, using 3/8 x 2-1/4 bolt (item 14), 3/8 washer (item 2) and a lock nut (item 1), bolt torque arm to gear block and finger tighten the nut.
3. Place 3/4" washer (item 7) onto keyway end of shaft.
4. Insert the size 9 woodruff key (item 6) into keyway on the shaft.
5. Install drive sprocket (item 5), hub side first, over woodruff key.
6. While pressing the drive sprocket and the MORStop™ assembly against the gear block, tighten setscrews on drive sprocket.
7. If installing a chain wheel (item 16), slide chain wheel chain guide (item 15) over MORStop™ shaft onto step. (This step not needed if installing hand crank or hand wheel.)
8. Slip chain wheel (item 16), hand crank (item 17), or hand wheel (item 18) onto MORStop™ shaft and line up 3/16" holes for roll pin (item 12). Carefully hammer in roll pin through both parts.
9. Tighten torque arm nut & bolt from step 2. Loosen the lock nut ½ turn to prevent possible binding in the MORStop™. There will be a slight drag in the MORStop™ while turning the crank device, but no binding should be present.
10. Reinstall the roller chain over the drive sprocket using master link, side link and retaining clip. The master link must be installed with the spring clip on side opposite the spur gear.
11. Replace gear covers, if applicable.

After completing the installation of the MORStop™, the chain wheel, hand crank, or hand wheel should turn freely in either direction, and will prevent the load from back driving the crank device.

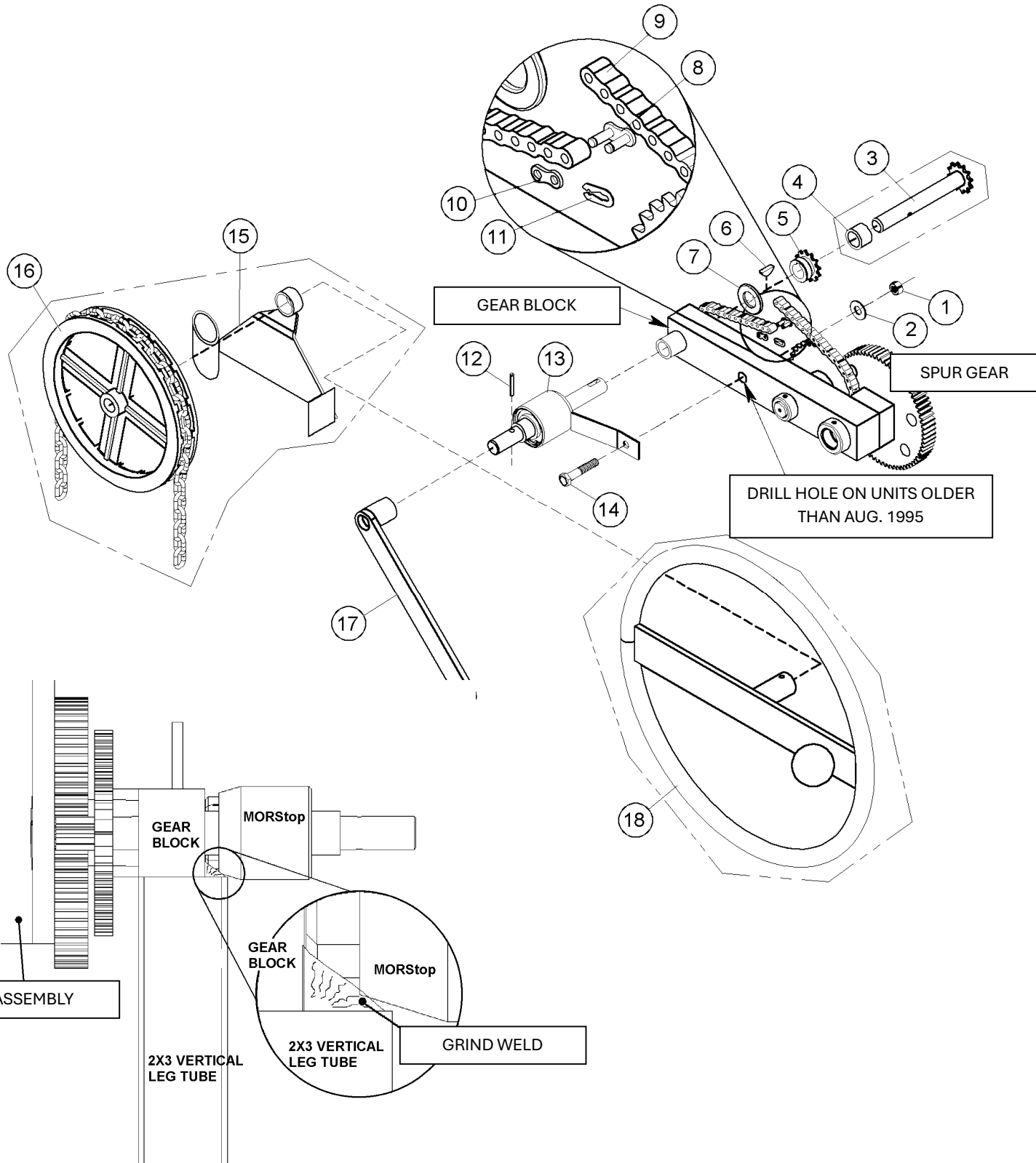

Items included in MORStop™ Tilt-Brake Kit			
ITEM	QTY.	PART NUMBER	DESCRIPTION
1	1	3981SS-P	NUT, 3/8-16 NYLON LOCK, SS
2	1	1166SS-P	WASHER, 3/8 USS, SS
5	1	11-P	SPROCKET, #35 12T, 3/4" BORE
6	1	735SS-P	KEY, WOODRUFF, SIZE 9, T304SS
7	1	55SS-P	WASHER, 3/4 SAE FL 1-1/2 OD SS
12	1	64SS-P	ROLL PIN, 3/16 X 1-1/4, SS
13	1	3901SS-P	MORStop TILT BRAKE, SS
14	1	82SS-P	HHCS, 3/8-16 X 2-1/4, SS

Other items shown in Diagram			
ITEM	QTY.	PART NUMBER	DESCRIPTION
15	1	5245-P	GUIDE, POCKET CHAIN WHEEL
16	1	1303SS-P	POCKET CHAIN WHEEL SILVER PC
17	1	5USS-P	HAND CRANK, W/ SOCKET TUBE, SS
18	1	2685SS-P	HANDWHEEL 16" SS 3/4B w/ KNOB