

**Operator's Manual
 for Morse Hydra-Lift Drum Rollers
 456 Series**

Serial Number 206720 to 266288

Contents

	Page
Receiving Procedures.	1
Warranty.	1
Safety Information.	1 - 2
Machine Description.	3
Options.	3
Installation Instructions.	3 - 4
Operating Instructions.	4 - 5
Maintenance.	5
Parts Lists and Diagrams.	6 - 9

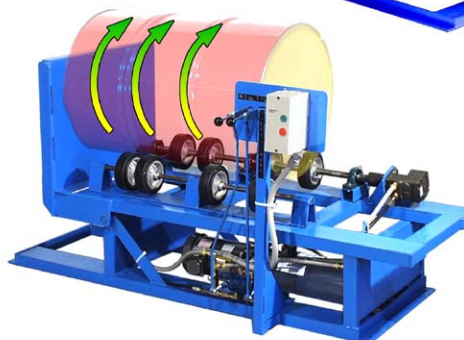

Receiving Procedures

Every Morse drum handler is inspected prior to shipping. However, damage may be incurred during transit.

- Check for visible damage. If you choose to accept damaged freight, always sign noting the damage on the **Bill of Lading**.
- Document the damage and have the truck driver sign. We recommend keeping a digital camera at your receiving dock for this purpose.
- Open packages expeditiously to check the condition of the goods. There is only a 24 hour window to notify the carrier of any concealed damage.
- Immediately **report all damage to the shipping company!** Then you may contact Morse for assistance with your freight claim.
- Morse Manufacturing will not be held responsible for any damaged freight that is not signed for as damaged.

Limited 2 Year Warranty

Morse drum handling equipment is guaranteed against defects in workmanship or materials for two years when used properly within its rated capacity. Warranty does not cover wear from normal use or damage from accident or abuse. Motors and other purchased parts carry the warranties of their manufacturers.

For warranty claims, contact your Morse Dealer to obtain a return authorization number, and for return freight advice. Return freight must be prepaid.

In all instances, liability is limited to the purchase price paid or to repairing or replacing the product. Customer assumes liability for any modifications, unauthorized repairs or parts substitution.

Safety Information

While Morse Manufacturing Co. drum handling equipment is engineered for safety and efficiency, a high degree of responsibility must be placed upon the machine operator to follow safe practices, based primarily on common sense, upon which true safety depends.

Failure to follow the safety precautions in this manual can result in personal injury or property damage. Observe the same precautions as with similar machinery where carelessness in operating or maintenance is hazardous to personnel. Carefully read the safety precautions below and throughout this manual.

Review the Material Safety Data Sheet(s) for the material(s) in the drum(s) and take all necessary precautions. Safety shoes, work gloves, hard hat and other personal protective devices are recommended.

Prior to initial use, inspect all moving parts and test rotation of wheels. Perform necessary inspections, operator training, etc.

Operator's Manual for Morse 456 Series Hydra-Lift Drum Rollers Serial Number 206720 to 266288

Safety Information (continued)



DANGER - Indicates a situation which, if not avoided, will result in serious injury or death. This signal word is limited to the most extreme situations.



WARNING - Indicates a situation which, if not avoided, could result in serious injury or death.



CAUTION - Indicates a situation which, if not avoided, can result in damage to the machine.



DANGER - Watch Out for Pinch Points. Stay clear of moving parts. Do Not Stand Near any Part of a Rotating Drum or Drum Holder. Operator should remain directly in front of the control station while operating the rotator. Morse Drum Rotators should be installed in accordance with OSHA subpart O, 1910.212 - "General requirements for all machines." "Revolving drums, barrels, and containers shall be guarded by an enclosure which is interlocked with the drive mechanism, so that the barrel, drum, or container cannot revolve unless the guard enclosure is in place." (An optional safety enclosure can be ordered for any MORSE drum rotator.)



WARNING - The 456 Series is designed to handle one drum of the types listed at the top of page 3 under machine description. DO NOT attempt to handle any other type of drum or object. DO NOT exceed the weight capacity.



WARNING - Level Floors Only. For operation only on clean, level floors of suitable bearing capacity. Do not use on sloped surfaces, ramps, irregular or debris strewn floors.



WARNING - Properly Mount to Floor. Do Not put into service without proper floor mounting and leveling. Use the four mounting holes in each corner of the base to anchor to floor.



WARNING - Do Not Modify the Unit. Under no circumstances should any modifications be made to the Morse machinery without factory authorization. Any modifications may void the warranty. This machine was designed to perform a specific job and alterations may result in injury to operator or machine.



WARNING - No Loose Fitting Clothing. Wear close-fitting clothing and safety equipment appropriate to the job. Loose fitting clothing may become caught on the machinery and cause severe personal injury.



WARNING - Hydraulic Fluid Under Pressure Can Be Hazardous. Escaping hydraulic fluid under pressure can penetrate the skin, causing serious injury. Avoid the hazard by relieving pressure before disconnecting hydraulic lines. Keep hands and body away from pinholes and nozzles which eject fluid under high pressure. Use a piece of cardboard to search for leaks. If an accident occurs, see a doctor immediately and inform them of the nature of the accident.



CAUTION - Wear safety shoes with non-slip soles and hard toe protection.



CAUTION: DO NOT allow drum to impact on floor.

Operator's Manual for Morse 456 Series Hydra-Lift Drum Rollers Serial Number 206720 to 266288

Machine Description

The Morse 456 Series Hydra-Lift Drum Rollers are designed to receive an upright drum at floor level, hydraulically tilt drum to horizontal, and rotate the drum on its side between 5 and 20 RPM (4 to 16 RPM with 50Hz models). It is designed to rotate a steel drum 6" to 28" in diameter, and up to 40" tall. The maximum liquid capacity is 1000 Lb. Capacity is derated to 400 Lb. for a dry load.



See [VIDEO online](#)

Options

- A 1 to 5 gallon can or pail can be rotated with the optional Idler Attachment (part # 1-5-1) installed.
- A 55-gallon plastic drum can be rotated with the correct POLY option installed.
 - Order Option POLY-456 factory installed on your new 456 Series Drum Roller.
 - Order Option POLY-456FI for field installation of POLY Kit on your existing 456 Series Drum Roller.
- Guard Enclosure Kit - Install all Morse Rotators in accordance with OSHA requirements for enclosure and safety interlock, etc. so the rotator automatically turns off when enclosure door is opened. One way to accomplish this is with a Morse Guard Enclosure with safety interlock.

Model #	Motor Style	Phase	Volts	Hz	Amp Draw	Drum RPM
456-1-115	TEFC	1	115	60	12.8	5 to 20
456-1-230	TEFC	1	230	60	6.4	5 to 20
456-3-230	TEFC	3	230	60	3.4	5 to 20
456-3-460	TEFC	3	460	60	1.7	5 to 20
456-3-575	TEFC	3	575	60	2	5 to 20
456-A	Air Motor	Air Motor Technical Info				5 to 20
456-E1-115	Explosion Proof *	1	115	60	13	5 to 20
456-E1-230	Explosion Proof *	1	230	60	6.5	5 to 20
456-E3-230	Explosion Proof *	3	230	60	3.6	5 to 20
456-E3-460	Explosion Proof *	3	460	60	1.8	5 to 20
456-1-220-50	TEFC	1	220	50	6.2	4 to 16
456-3-220-50	TEFC	3	220	50	3.5	4 to 16
456-3-380-50	TEFC	3	380	50	2.1	4 to 16
456-3-440-50	TEFC	3	440	50	1.75	4 to 16
456-E1-220-50	Explosion Proof *	1	220	50	6.2	4 to 16
456-E3-220-50	Explosion Proof *	3	220	50	3.6	4 to 16
456-E3-380-50	Explosion Proof *	3	380	50	2.1	4 to 16
456-E3-440-50	Explosion Proof *	3	440	50	1.8	4 to 16

* Explosion Proof Motors are rated for Class I Group D, and Class II Groups F and G.

Controls

There are two powered functions for the operator to control. Each function is controlled separately by levers mounted on the control station.

1. The "TILT" function, for vertical positioning of the drum holder. The lever on the right side is the "TILT" control valve. Raising the lever will tilt the drum to vertical. Lowering the lever will tilt the drum to horizontal.
2. The "ROLL" function, or the rotation of the drum holder. The lever on the left side is the "ROLL" control valve. Raising this lever causes the drum to rotate. Lowering the lever away from the operator will stop the drum from rotating. The rotation speed can be varied with the flow control valve (item 47 on page 8). Turn the valve clockwise to increase speed up to a nominal 20 RPM, counterclockwise to decrease speed down to a nominal 5 RPM. RPM is based on a 22.5" diameter 55-gallon steel drum and a 60Hz 1725 RPM motor.

Installation Instructions

Hydra-Lift Rotators are shipped filled with 1 gallon of hydraulic fluid (Dexron 3 or equivalent). The base has four holes spaced 20.5" wide x 62" long. Morse recommends the rotator be secured to the floor using 1/2" x 3" lag bolts. Install all Morse Rotators in accordance with OSHA requirements for enclosure and safety interlock, etc. Drum rotator must automatically turn off when enclosure door is opened. Replace the red shipping plug from the hydraulic reservoir with the supplied black breather, and install hydraulic levers BEFORE operation.

START UP PROCEDURES

PUMP ROTATION IS CLOCKWISE VIEWING FROM THE MOTOR END. JOG THE MOTOR TO DETERMINE PROPER ROTATION. IN THE EVENT FLUID DOES NOT FLOW, CHECK MOTOR WIRING DIAGRAM FOR CLOCKWISE ROTATION.

Control Station - Making Connections:

- For the air motor powered rotator, a filter, regulator, lubricator is mounted on the control station. A shutoff ball valve is installed on the inlet of the regulator. The air connection should be made at the inlet of this valve.
- Ensure that the supply air lines are of sufficient size to provide proper air volume. The air motor requires 40 scfm, and 40 psi of compressed air. (The proper air pressure will depend on the weight of the drum.)
- For AC motor powered rotator, the main power must be wired into the control box. See wiring diagram included inside control box.
- Models ordered with non-explosion proof motor (i.e. 456-1-115) have the control box wired to the motor.
- Models ordered with explosion proof motor (i.e. 456-E1-115) have no wiring from the nema 7/9 control box to the motor. Please consult an electrician to complete the wiring. **The motor should turn clockwise when viewed from the fan end.** Jog the motor to determine proper rotation. In the event fluid does not flow, check motor wiring diagram for clockwise rotation.

**Operator's Manual for Morse 456 Series Hydra-Lift Drum Rollers
Serial Number 206720 to 266288**

Installation Instructions (continued)

Adjust drive and idler wheels to your particular drum. With provided 1/8" allen wrench, loosen the two set screws found in each drive wheel hub and the set screw in each collar surrounding the idler wheels. Wheels should be positioned to support the drum at its strongest point; adjacent to ribs (see Figure 1). This configuration will also prevent the drum from moving axially. Tighten set screws.

A variety of drum diameters can be accommodated by adjusting the idler plate assembly toward the drive side for smaller diameters and away from the drive side for larger diameters. The plate may be adjusted to allow drive shaft spacing from 8" to 18". It is preset to the second (outer) set of holes for use with standard 55-gallon steel drums. To adjust, remove the three idler plate bolts (item 8) and slide the idler plate assembly (item 7) to the proper set of mount holes and refasten the mount bolts.

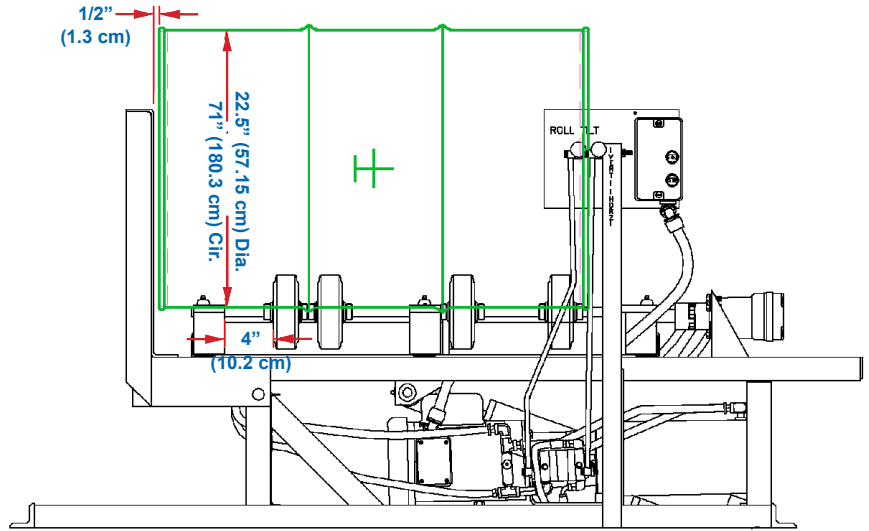

Figure 1

Loading a Drum

1. Raise the "TILT" lever to tilt the load plate to floor level.
2. Place a drum onto the load plate with a drum truck, a below-hook drum lifter, or the Morse [model 81 Drum Spotter](#).
3. Lower the "TILT" lever to tilt the drum from



Load drum with drum truck



Load drum with hoist attachment



Load drum with the Morse Drum Spotter



Lower the "TILT" lever to tilt the drum into horizontal position

upright into horizontal position.

Rotating a Drum

After ensuring that the area around the rotator is clear, raise the "ROLL" lever to begin rotation.



Raise the "ROLL" lever to begin rotation

The drum rotation speed can be varied with the flow control valve (item 47). Turn the valve clockwise to increase speed up to 20 RPM, counter-clockwise to decrease speed down to 5 RPM.

Alternate method on the air motor version: With the air shutoff ball valve in the OFF position, raise the "ROLL" lever. Then, slowly open the air shutoff ball valve to begin the rotation. This can allow for more control over the speed of rotation.



Vary the rotation speed with the flow control valve

Unloading a Drum

Ensure the drum is in vertical upright position to unload.

Operator's Manual for Morse 456 Series Hydra-Lift Drum Rollers
Serial Number 206720 to 266288

Maintenance

Periodic inspection for the general condition of structural and mechanical components is imperative for safe and efficient operation.

1. Idler wheels and drive bearings are equipped with grease fitting and should be lubricated periodically. High pressure grease guns are not recommended, as their force may damage seals.
2. Motors have permanently lubricated ball bearings.
3. Inspect the hydraulic system for oil drips, hose damage, or other signs of wear. Inspect the level and condition of the hydraulic fluid. Replace any parts that show signs of wear.
4. Lubricate all moving parts including: bearings and clevis pins.
5. Periodically inspect all moving parts, framework, contact areas, and floor mounting fasteners for signs of wear, fatigue, or loosening. Tighten, adjust or replace parts as necessary to prevent failure and maintain proper function.

Operator's Manual for Morse 456 Series Hydra-Lift Drum Rollers Serial Number 206720 to 266288

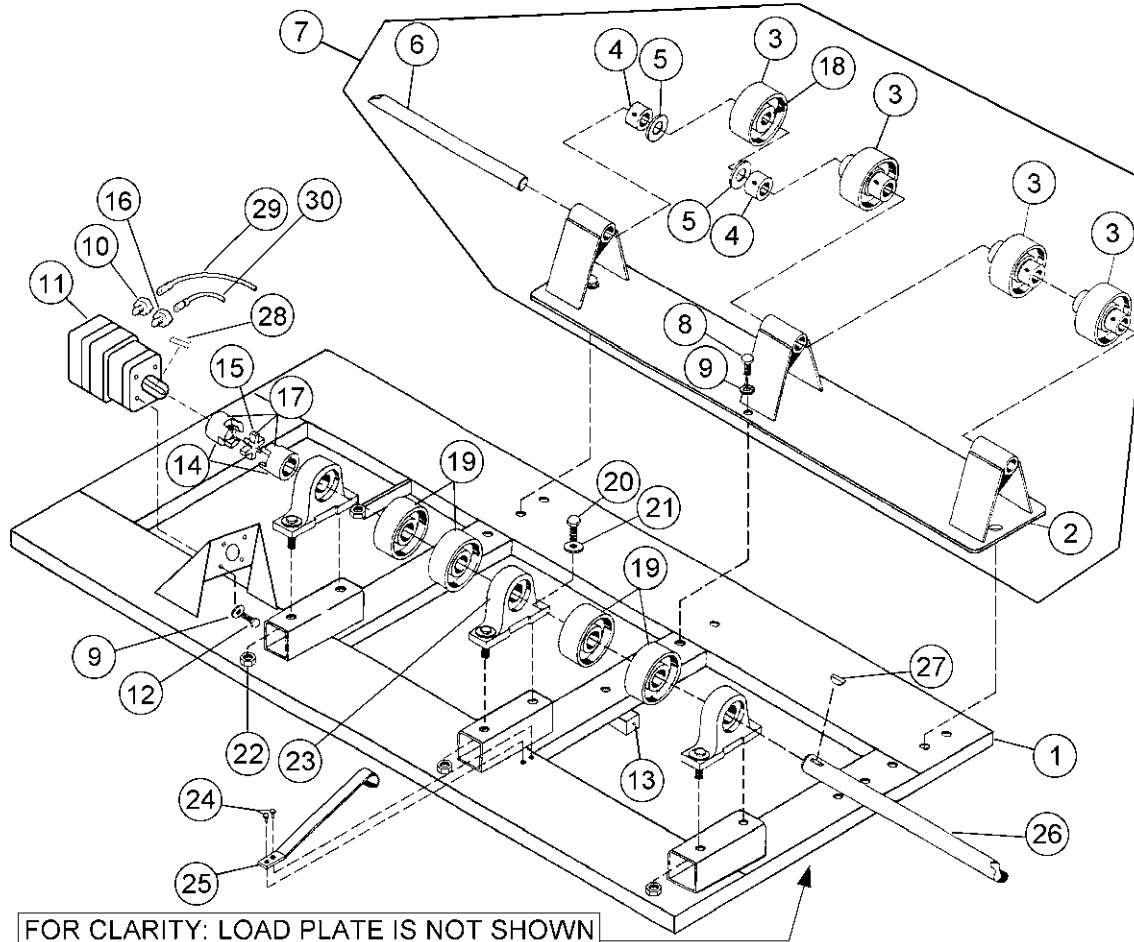

ITEM	QTY.	PART #	DESCRIPTION
1	1	1202-P	TILT BED WELD, 456
2	1	295-P	IDLER PLATE WELD, 5154
3 *	4	292-P	WHEEL, IDLER, 6" W/ 3/4" BRG
4	8	15-P	COLLAR, 3/4" ID
5	8	55-P	WASHER, 3/4 SAE FL 1-1/2 OD
6	1	301-P	IDLER SHAFT, 3/4" X 38" 5154
7	1	295CPT-P	IDLER PLATE CPT, 1-5154
8	3	1657-P	HHCS, 3/8-16 X 3/4 GR2
9	11	1474-P	WASHER, 3/8 SPLIT LOCK
10	1	2175-P	HYD FITTING 1/2 X 3/8 PUSH LOK
11	1	351-P	MOTOR, HYDRAULIC HYD, 400, 456
12	6	1572-P	HHCS, 3/8-16 X 1 GR2
14	2	1665-P	COUPLING BODY HALF, 1" BORE
15 *	1	305-P	SPIDER, BUNA N, 5154
16	1	2120-P	HYD FIT, MALE CONNECTOR, 400

ITEM	QTY.	PART #	DESCRIPTION
17	1	2808-P	COUPLING CPT, 1" TO 1"
18 *	4	1875-P	BEARING, 3/4" ID, 6" WHEEL
19 *	4	291-P	WHEEL, DRIVE, 6", 1" BORE
20	8	535-P	HHCS, 3/8-16 X 1-1/4 GR5
21	10	1166-P	WASHER, 3/8 USS 1" OD
22	7	1169-P	NUT, 3/8-16 REV HEX LOCK
23	3	297-P	BEARING, 1" PILLOW BLOCK
24	2	213-P	SCREW, #7 X 5/16 DRIVE
25	1	217-P	GROUNDING STRAP, 5154, 201
26	1	299-P	DRIVE SHAFT, 1" X 40" 5154
27	1	736-P	KEY, WOODRUFF, SIZE 15, ASA808
28	1	2656-P	KEY, SQUARE, 1/4 X 1"
29	1	2177-P	RETURN HOSE, PUSH LOK, 79" 456
30	1	2810-P	HYD HOSE ASM, 75-1/4", 456

**Operator's Manual for Morse 456 Series Hydra-Lift Drum Rollers
Serial Number 206720 to 266288**

ITEM	MODEL SUFFIX	QTY.	PART #	DESCRIPTION
31		1	1204-P	BASE WELD, 456
32	-1-115, -1-230	1	290-1-2P	MOTOR, 1HP, 1PH, 56C, TEFC
32	-3-230, -3-460	1	290-3-2P	MOTOR, 1HP, 3PH, 56C, TEFC
32	-A	1	290-A-2P	MOTOR, AIR 2HP, 56C
32	-E1-115, -E1-230	1	290-E1-2P	MOTOR, 1HP, 1PH, 56C, EXP
32	-E3-230, -E3-460	1	290-E3-2P	MOTOR, 1HP, 3PH, 56C, EXP
33		2	2809-P	HYD HOSE ASM, 21", 456
34		1	M404-456-P	HYD POWER PACK, 456
35		1	2178-P	RETURN HOSE, PUSH LOK 17", 456
36	3-PHASE NON EXP	1	2790-P	WIRE, 14 AWG, 456, 3PH, 46.25
36	1 PHASE NON EXP	1	3184-P	WIRE, 14 AWG, 456, 1PH, 46.25
37	ALL AC NON EXP	1	2788-P	CONDUIT, POLY FLEX, 1/2" 34.25
38	ALL AC NON EXP	1	2789-P	FIT, CONDUIT, 90DEG POLY
39	-1-115	1	1239-P	CONTROL BOX, 456-1-115
39	-1-230, -1-220-50	1	1240C-P	CONTROL BOX, 456-1-230 CAGE
39	-3-230, -3-220-50	1	3215C-P	CONTROL BOX, 310-3-230 CAGE
39	3-460, -3-440-50	1	3216C-P	CONTROL BOX, 310-3-460 CAGE
39	-E1-115	1	3814-P	CONTROL BOX, 456-E1 310-E1-230
39	-E1-230, -E1-220-50	1	3815-P	CONTROL BOX, 456-E1-230
39	-E3-230, -E3-220-50	1	3816-P	CONTROL BOX, 456-E3 310-E3-460
39	E3-380-50, -E3-460, -E3-440-50	1	3817-P	CONTROL BOX, 456-E3-460
39	-A	1	90020-P	FRL ASM, KIT, 3/8", REGULATOR
40	ALL AC NON EXP	2	3393-P	SHCS, 8-32 X 5/8 BUTTON
40	ALL AC EXP	2	1641-P	HHCS, 1/4-20 X 1 GR2
41	ALL AC NON EXP	2	3394-P	NUT, 8-32 NYLON LOCK
41	ALL AC EXP	2	1297-P	NUT, 1/4-20 REV HEX LOCK
42 *		2	M01326-P	ROD, VALVE HANDLE, MON
43 *		2	M01157-P	BALL, PLASTIC, HANDLE, MON
44		1	2812-P	CONTROL PUSH ROD, TILT, 456
45		1	2811-P	CONTROL PUSH ROD, ROLL, 456
46		1	648-P	CYLINDER, 3" X 16", SAE, 456
47		1	339-P	FLOW CONTROL VALVE F-400-B-11
48		2	3610-P	HYD FIT, MALE ELBOW, SAE
49		1	345-P	HYD FIT, MALE FLARE, 456, 82
50		3	33-P	ALEMITE GREASE FIT
51		2	2170-P	PIN, CYL, 1" DIA X 3", 456
52		2	1637-P	ROLL PIN, 3/16 X 1-1/2
53		2	1883-P	WASHER, 1" SAE FL 2" OD
54		1	2163-P	HINGE SHAFT, 1" X 25.25, 456
55	(NOT SHOWN)	2	16-P	COLLAR, 1" ID
56		4	170-P	SCREW, 3/8 DIA X 5/8 SHOULDER
57		1	2171-P	HHCS, 3/8-16 X 4-3/4 GR5
58		1	2161-P	SPACER, BOLT, 456, HANDWHEEL
59		2	2174-P	HANDLE HOLDER, 456
60		2	2173-P	BOLT, LINK EYE, 456
61		3	2118-P	HYD FIT, STREET ELBOW, 1/4
62		5	1107-P	HYD FIT, PUSH LOK 1/4 X 3/8
63		2	1105-P	HYD FIT, RUN TEE, 456, 310
64		1	1109-P	HYD FIT, BRANCH TEE, 456
65		1	1182-P	HYD FIT, LONG NIPPLE 2-1/2 456
66		2	765-P	HYD FIT, MALE ELBOW, FLARE 400
67		1	M07381-P	VALVE 3-4 WAY ROUND ROUND 456
68		1	2172-P	HHCS, 1/2-13 X 1-1/2 GR5
69		1	3326-P	RETURN HOSE, PUSH LOK 15", 456
* Recommended spare parts				

**Operator's Manual for Morse 456 Series Hydra-Lift Drum Rollers
 Serial Number 206720 to 266288**

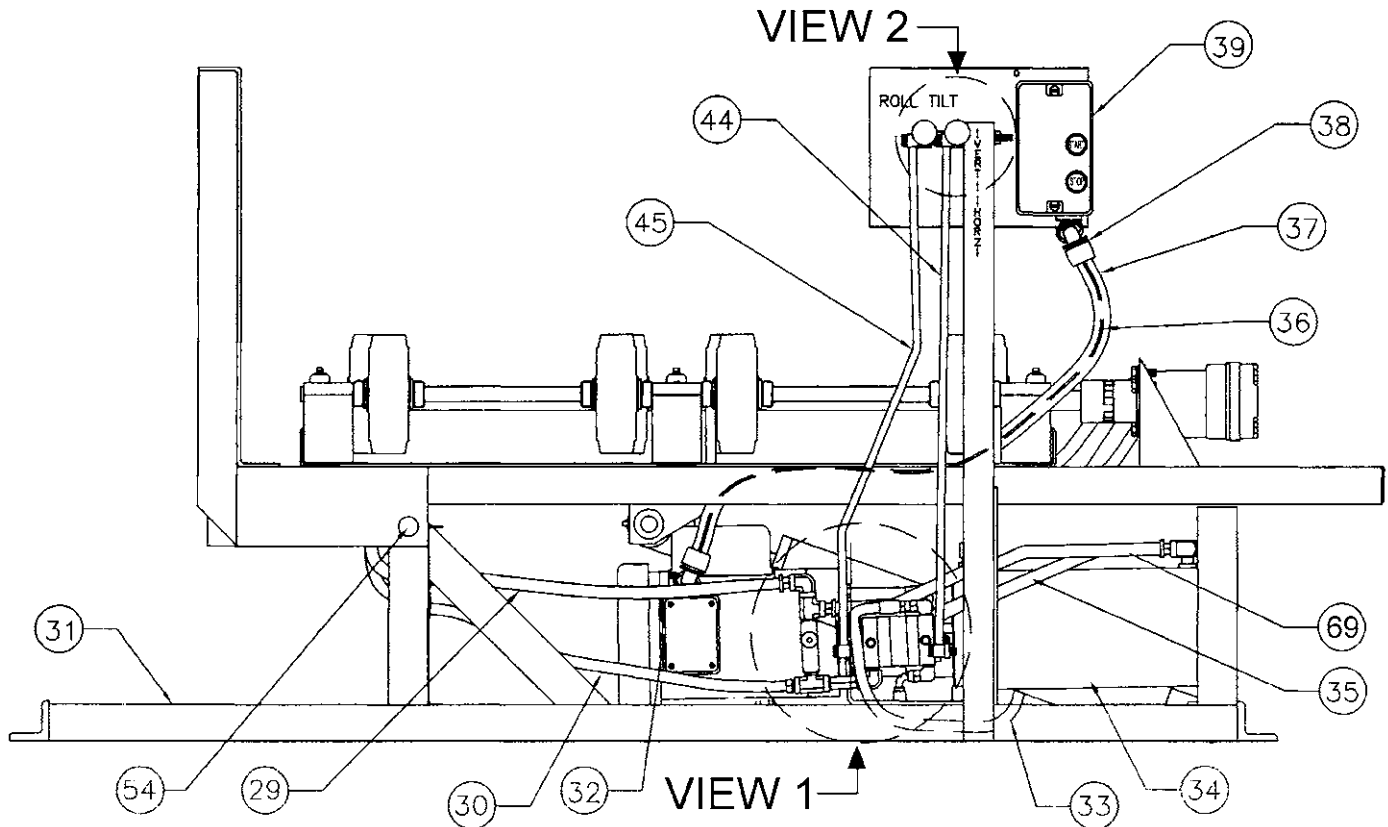
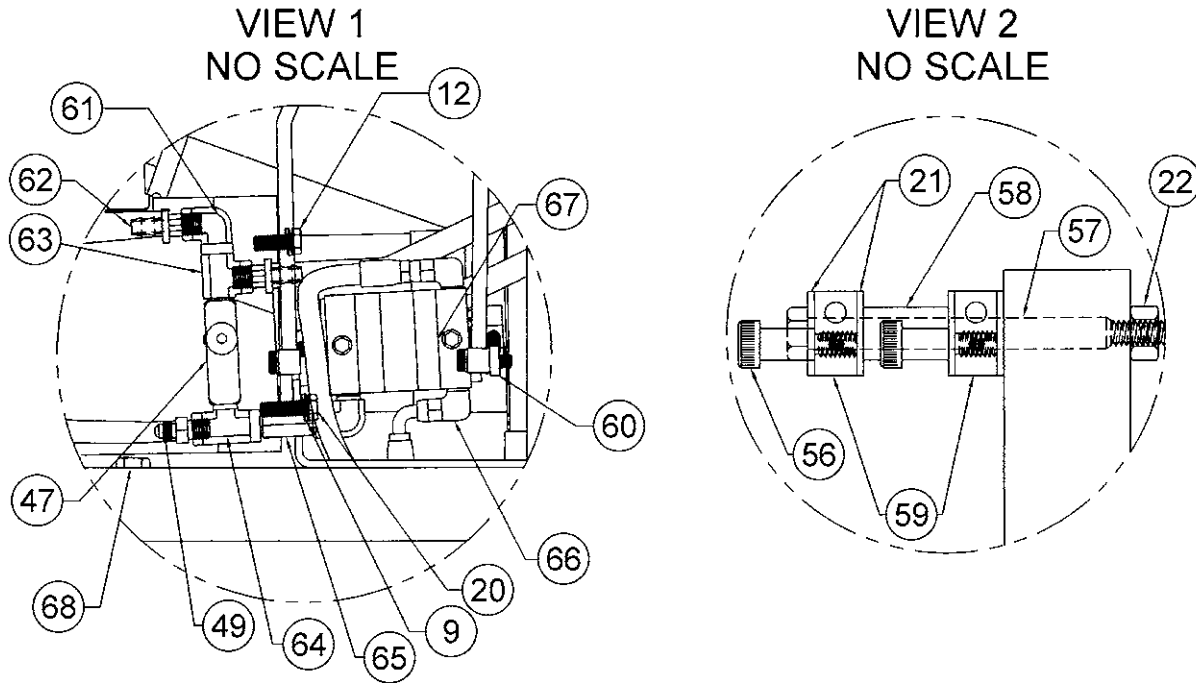

**Operator's Manual for Morse 456 Series Hydra-Lift Drum Rollers
 Serial Number 206720 to 266288**

VIEW 3
 NO SCALE

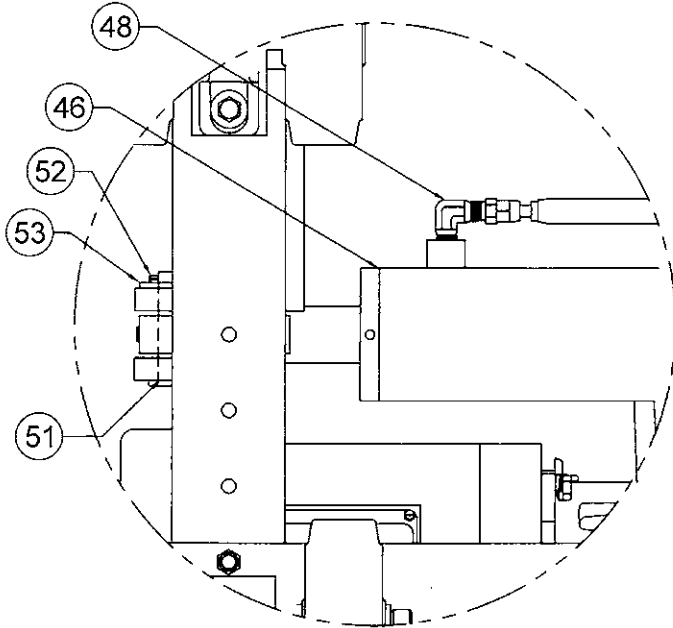

VIEW 4
 NO SCALE

