

**Built-in Hydraulics Tilt Upright Drum to Horizontal**

**Mixing In Closed Drum Means Less Hazards**

- Ergonomic powered hydraulics tilt drum from upright over to rolling position
- Save time, labor and money by mixing inside a closed drum
- Remix settled ingredients, and integrate new components
- Eliminate transfer and clean-up
  - Use separate drum for each batch
  - No container to purge between batches
  - Nothing to insert into drum
- Drums make economical mixing vessels
- Maximum ambient operating temp: 130° F (54° C)

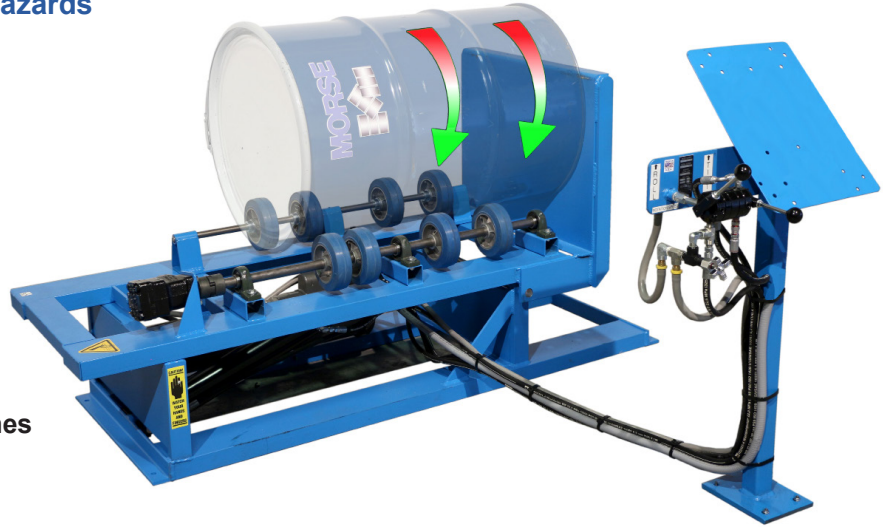

**Load upright drum at floor level with drum truck or your crane**



Load drum onto Hydra-Lift Drum Roller with drum truck, [model 160-WP shown](#)... a simple way to load and remove drum



Load drum with your hoist or crane and a [Below-the-Hook Drum Lifter](#), model 92 shown

Hydra-Lift Drum Rollers can eliminate spills, splashing of dangerous contents on workers, and risk of contamination. Mix inside closed shipping drums and have the machine do the work of loading and unloading itself!

Load an upright drum into the Hydra-Lift Drum Roller. You control the hydraulic tilting action that places the drum down onto the rotator wheels. Then use a second control to start and stop the hydraulic motor that drives rotation.

Minimize time, labor and extra equipment of getting drum into mixing position.

- Roll a 22.5" (57.2 cm) diameter drum from 5 to 17 RPM, or 4 to 14 RPM on 50Hz models.
- Capacity: 1000 Lb. (454 kg) liquid load, 400 Lb. (182 kg) dry load. A shifting dry load exerts greater stress on the drum rotator than the fluid motion of a liquid load.
- Roll a Drum: 6" to 26" (15.25 to 66 cm) in diameter, and with 40" (102 cm) maximum length

**Power drum tilt**



Use the built-in hydraulic system to move an upright drum over to horizontal position for rolling.

- Model # 456-1 Hydra-Lift Drum Roller
- Model # CP-456-1-115 Control Package (sold separately)
- Shown without Enclosure for clarity only

**Vary drum rolling speed**



Roll 55-gallon (210L) drum with variable speed hydraulic drive from 5 to 17 RPM (4 to 14 RPM on 50Hz models).

**Options**

**Roll a Plastic Drum**

**Option # POLY-456**

Factory Installed option REQUIRED to safely roll a plastic drum. Includes extra wheels to support flexible soft-sided plastic drum, and end stop to prevent drum from traveling length-ways. This is a factory installed OPTION on a NEW Hydra-Lift Drum Roller. It is **NOT** a drum roller by itself.

**Kit # POLY-456FI**

Kit for CUSTOMER to install on EXISTING Hydra-Lift Drum Roller.

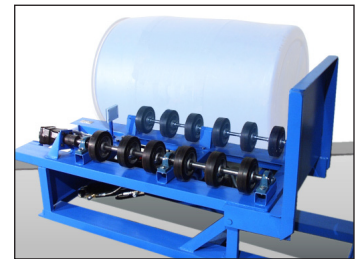

**Roll a 5-Gallon Pail**

**Kit # 1-5-1**

Bolt-on Idler Attachment to roll 1 to 5 gallon (3.8 to 18.9 liter) cylinder on Hydra-Lift Drum Roller. Spacers adjust for up to 18" (45.7 cm) tall pail. Roll 5-gallon can at approximately double RPM of a 55-gallon (210 liter) drum. Easily remove Idler to return to rolling a drum.

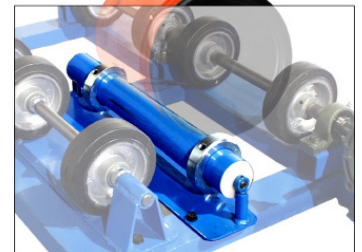

MADE  
IN  
USA

Loading Upright Drum

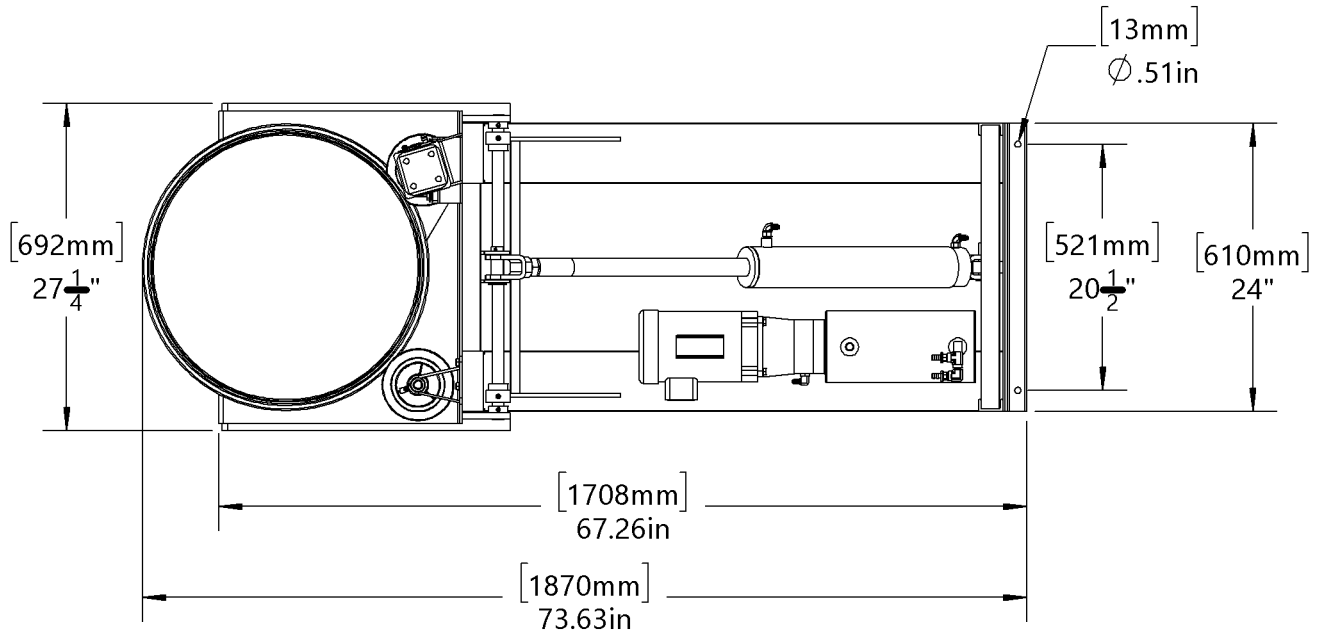

MADE  
 IN  
 USA

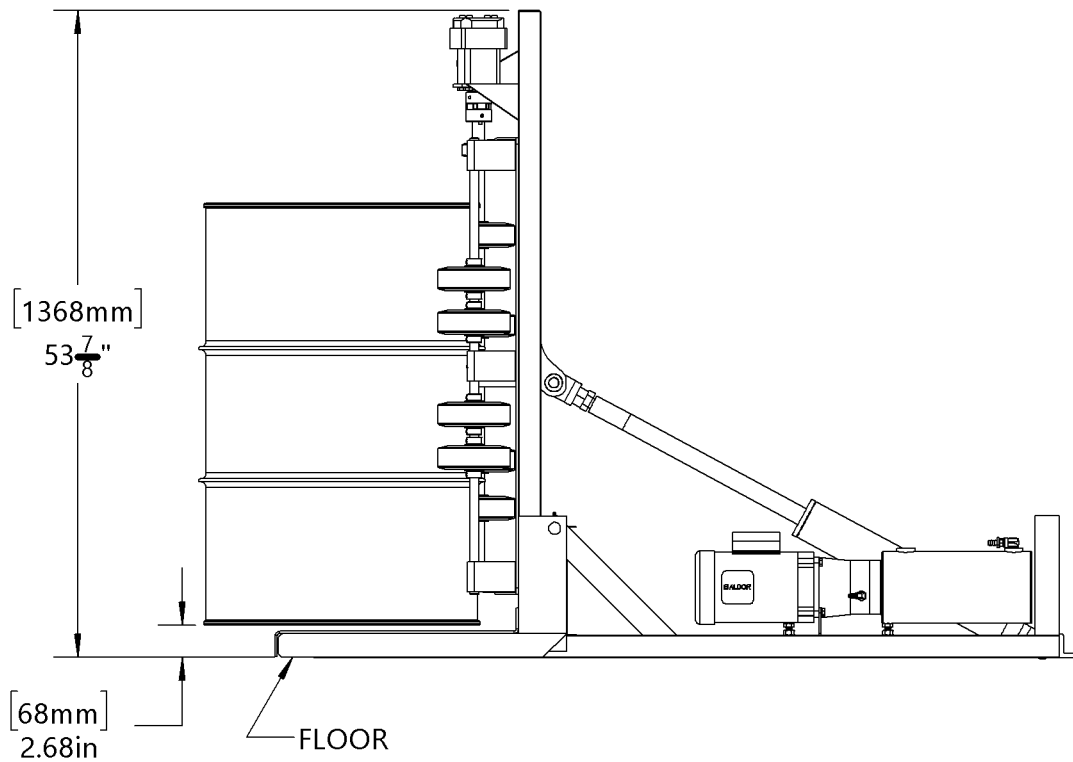

Drum in Rolling Position

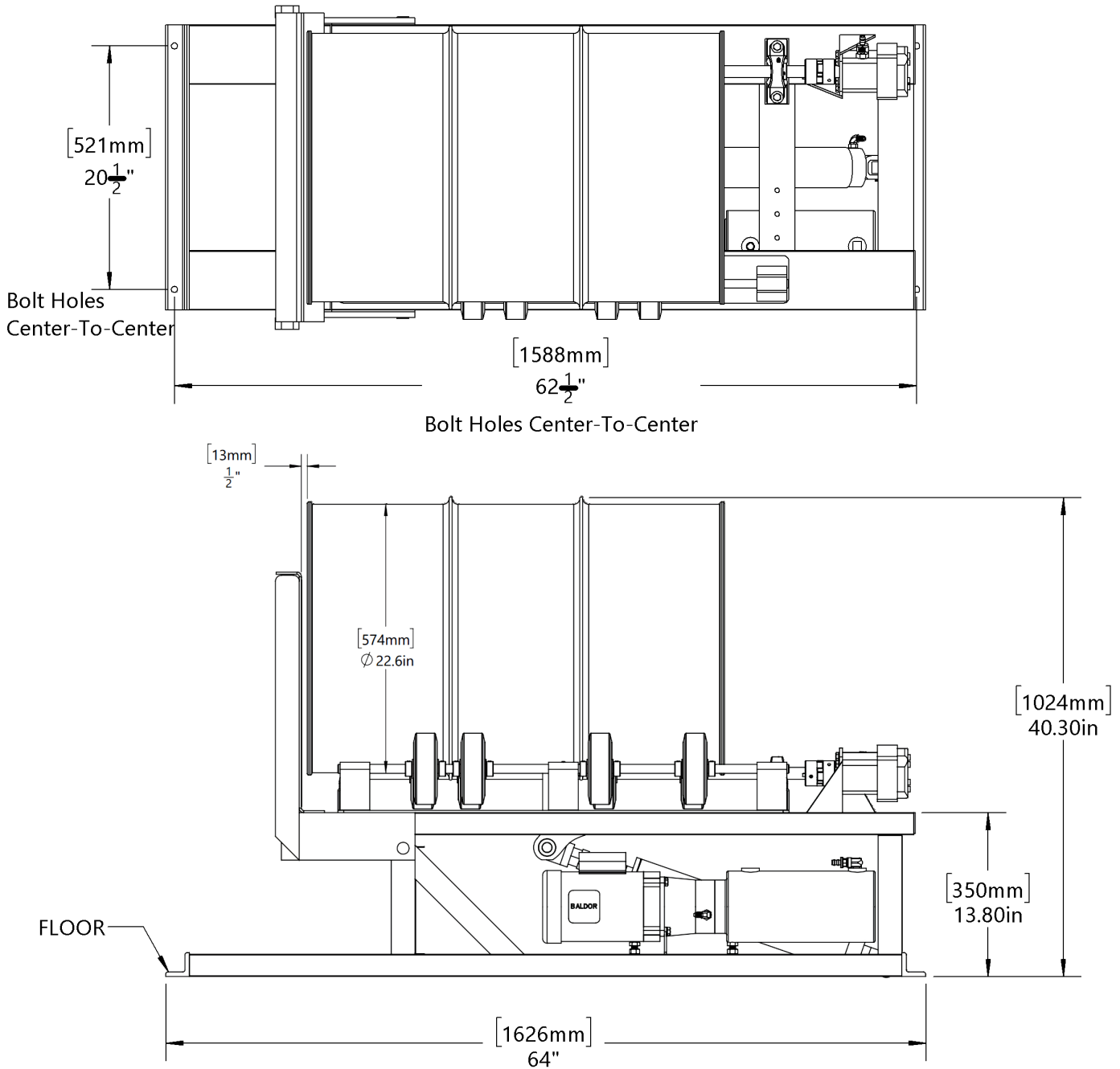

MADE  
 IN  
 USA

Hydra-Lift Drum Rollers							Control Packages See Page 3	Guard Enclosure Kits See Page 4
Model #	Drum RPM (22.5" Dia.)	Motor Information					Option #	Option #
		Motor Style	HP	Phase	Motor Voltage	Amp Draw		
456-1	5 to 17	60 Hz TEFC	1	1	115	12.8	CP-456-1-115 *	GEK-456-1
					208	7.0	CP-456-1-230 *	
					230	6.4		
456-1-50	4 to 14	50Hz TEFC	1	1	220	6.2	CP-456-1-220-50 *	GEK-456-1
456-3	5 to 17	60Hz TEFC	1	3	208	3.1	CP-456-3-230 *	GEK-456-3
					230	3.0		
					460	1.5	CP-456-3-460 *	
456-3-50	4 to 14	50Hz TEFC	1	3	230	3.1	CP-456-3-230-50 *	GEK-456-3
					400	1.8	CP-456-3-400-50 *	
456-3-575	5 to 17	60Hz TEFC	1	3	575	1.2	CP-456-3-575 *	GEK-456-3
456-E1	5 to 17	60Hz Explosion proof **	1	1	115	13	CP-456-E1-115 *	GEK-456-E1
					208	6.7	CP-456-E1-208 *	
					230	6.5	CP-456-E1-230 *	
456-E1-50	4 to 14	50Hz Explosion proof †	1	1	220	6.2	CP-456-E1-220-50 *	GEK-456-E1
456-E3	5 to 17	60Hz Explosion proof **	1	3	208	3.1	CP-456-E3-208 *	GEK-456-E3
					230	3.0	CP-456-E3-230 *	
					460	1.5	CP-456-E3-460 *	
456-E3-50	4 to 14	50Hz Explosion proof **	1	3	230	3.5	CP-456-E3-230-50 *	GEK-456-E3
					400	2.0	CP-456-E3-400-50 *	
456-E3-575	5 to 17	60Hz Explosion proof **	1	3	575	1.2	CP-456-E3-575 *	GEK-456-E3
456-A	5 to 17	Air Motor ***	-	-	-	-	Air Controls are included with model 456-A ***	GEK-456-A

MADE IN USA

\* ONLY NON-Explosion Proof AC Control Packages include a pre-wired control box. Explosion-Proof Control Packages have no wiring from the NEMA 7/9 control box to the motor. Please consult an electrician to complete the wiring in accordance to your local code.

\*\* Explosion-proof motors are rated for Class I Group D, and Class II Groups F and G.

\*\*\* Air powered model requires plant air at 40 to 60 PSI and flowing at a rate of 40 SCFM. Filter, Regulator, Lubricator and valve are included with drum roller model 456-A.

† Model 456-E1-50 has explosion-proof motor rated for Class 1 Group D.

Crates for Export	
Export Crate #	Description
2848X-P	Fully Enclosed Crate for Export of (1) Hydra-Lift Drum Roller, with or without (1) Control Package
4463X-P	Fully Enclosed Crate for Export of (1) Guard Enclosure Kit
5516X-P	Fully Enclosed Crate for Export of (1) Hydra-Lift Drum Roller, (1) Control Package and (1) Guard Enclosure Kit

**Control Packages (sold separately)**

Select the appropriate Control Package for each model, and your power supply. Use power controls to start and stop drum rolling. The control mast can be positioned outside the Safety Enclosure on either the left or right side, or at the back of Drum Roller.

**AC Control Package (sold separately) NEMA 4/12 for NON-Hazardous Areas**

Includes Control Box with:

- Timer adjusts from a few seconds to 16 hours
- Start and Stop Buttons
- Red Emergency Stop Button
- Lockable Main Disconnect to shut off and lock out power to the unit
- Wire terminals for external connection of safety interlock switch

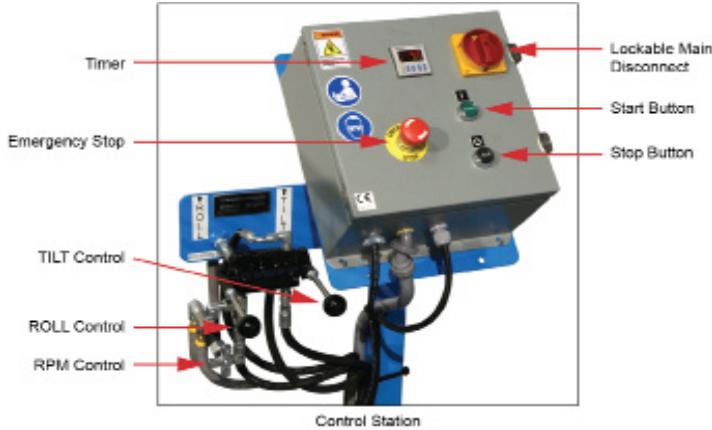

**Explosion Proof AC Control Package (sold separately) NEMA 7/9 for Hazardous Areas**

Includes Control Box with:

- Start and Stop Buttons
- Wire terminals for external connection of safety interlock switch



MADE IN USA

Control Package #	Description	Minimum Power Supply Required	Power Supply
<b>CP-456-1-115 *</b>	Control Package for 456-1	20 Amp	1-Phase 115V 60Hz
<b>CP-456-1-230 *</b>	Control Package for 456-1	15 Amp	1-Phase 230V 60Hz
<b>CP-456-1-220-50</b>	Control Package for 456-1-50	15 Amp	1-Phase 220V 50Hz
<b>CP-456-3-230 *</b>	Control Package for 456-3	15 Amp	3-Phase 230V 60Hz
<b>CP-456-3-460 *</b>	Control Package for 456-3	15 Amp	3-Phase 460V 60Hz
<b>CP-456-3-230-50</b>	Control Package for 456-3-50	15 Amp	3-Phase 230V 50Hz
<b>CP-456-3-400-50</b>	Control Package for 456-3-50	15 Amp	3-Phase 400V 50Hz
<b>CP-456-3-575</b>	Control Package for 456-3-575	15 Amp	3-Phase 575V 60Hz
<b>CP-456-E1-115 *</b>	Control Package for 456-E1, Explosion-Proof	20 Amp	1-Phase 115V 60Hz
<b>CP-456-E1-208 *</b>	Control Package for 456-E1, Explosion-Proof	15 Amp	1-Phase 208V 60Hz
<b>CP-456-E1-230 *</b>	Control Package for 456-E1, Explosion-Proof	15 Amp	1-Phase 230V 60Hz
<b>CP-456-E1-220-50 *</b>	Control Package for 456-E1-50, Explosion-Proof	15 Amp	1-Phase 220V 50Hz
<b>CP-456-E3-208 *</b>	Control Package for 456-E3, Explosion-Proof	15 Amp	3-Phase 208V 60Hz
<b>CP-456-E3-230 *</b>	Control Package for 456-E3, Explosion-Proof	15 Amp	3-Phase 230V 60Hz
<b>CP-456-E3-230-50 *</b>	Control Package for 456-E3-50, Explosion-Proof	15 Amp	3-Phase 230V 50Hz
<b>CP-456-E3-460 *</b>	Control Package for 456-E3, Explosion-Proof	15 Amp	3-Phase 460V 60Hz
<b>CP-456-E3-400-50 *</b>	Control Package for 456-E3-50, Explosion-Proof	15 Amp	3-Phase 400V 50Hz
<b>CP-456-E3-575 *</b>	Control Package for 456-E3-575, Explosion-Proof	15 Amp	3-Phase 575V 60Hz

**Air Controls are Included with Model 456-A**

**Air Controls Include**

- Filter, Regulator and Lubricator (FRL)
- On / Off Valve



**Control Station Dimensions for NON-Hazardous Areas**

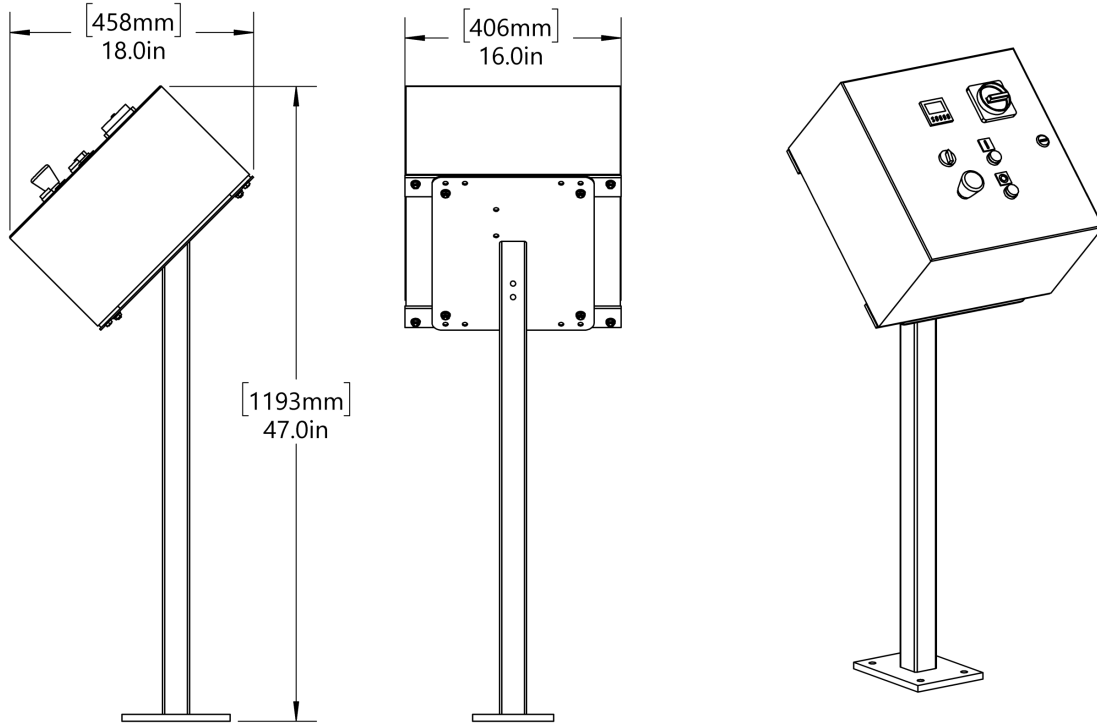

MADE  
 IN  
 USA

**Control Station Dimensions with Explosion-Proof Box for Hazardous Areas**

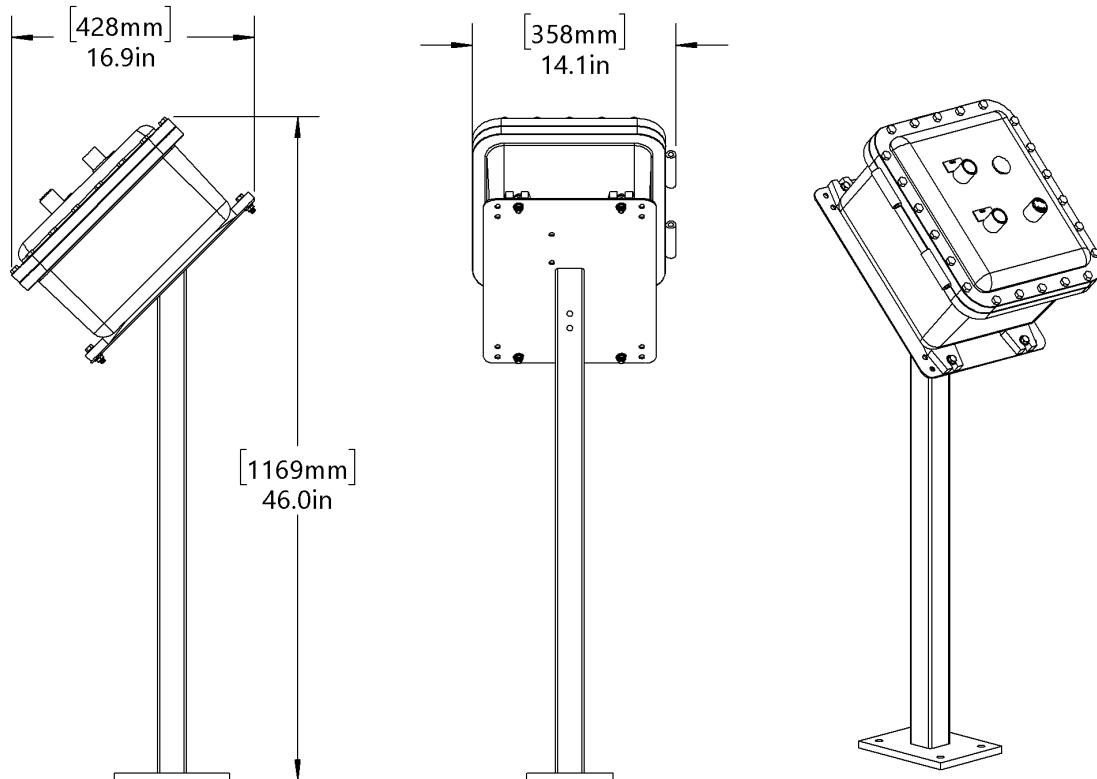

**Guard Enclosure Kits with Safety Interlock (sold separately)**

**Comply with OSHA Requirements with a Morse Guard Enclosure Kit (Sold Separately)**

Guard Enclosures for Morse Hydra-Lift Drum Rollers have a safety interlock to automatically shut off the drum roller when the gate is opened. Open the enclosure gate, place your drum onto the drum roller, then close the gate to allow operation. Connections are included for air powered model only. Morse Control Packages (page 3) provide controls and connections for AC models.

All Morse Control Packages (see page 3) include a low-voltage transformer and wire terminals required to connect the external safety interlock switch of these Guard Enclosure Kits. Morse Control Packages and Enclosures meet OSHA regulations ONLY when installed properly with safety interlock.

Install all Morse Rotators in accordance with local requirements for enclosure and safety interlock, etc. One way to accomplish this is with a Morse enclosure with safety interlock, so the rotator automatically turns off when enclosure door is opened. Power connections and motor controls must also comply with applicable local codes.

For OSHA compliance in the USA, see OSHA subpart O.1910.212(a) (4) "Barrels, containers, and drums. Revolving drums, barrels, and containers shall be guarded by an enclosure which is interlocked with the drive mechanism, so that the barrel, drum, or container cannot revolve unless the guard enclosure is in place."

Guard Enclosure Kit #	Description	Gate Switch
<b>GEK-456-1</b>	Fits Hydra-Lift Drum Roller with 1-phase electric motor	AC
<b>GEK-456-3</b>	Fits Hydra-Lift Drum Roller with 3-phase electric motor	AC
<b>GEK-456-E1</b>	Fits Hydra-Lift Drum Roller with Explosion-proof 1-phase electric motor	AC
<b>GEK-456-E3</b>	Fits Hydra-Lift Drum Roller with Explosion-proof 3-phase electric motor	AC
<b>GEK-456-A</b>	Fits Hydra-Lift Drum Roller with Air motor	AIR

MADE  
IN  
USA

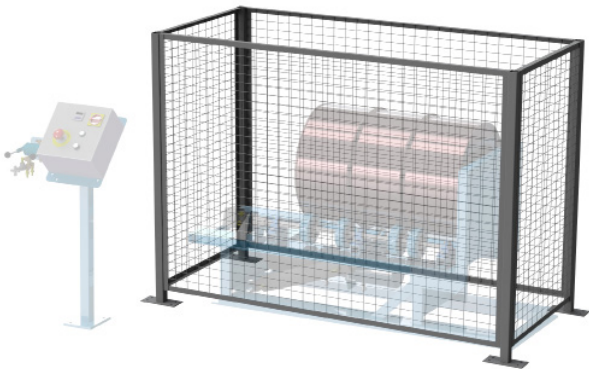

Guard Enclosure with safety interlock (shown with Drum Roller and Control Package each sold separately)

**Outside Post-to-Post Dimensions of Enclosures**

L88" x W40" x H63.205" (224 x 102 x 161 cm)

