

Super-Duty Kontrol-Karriers

MADE
IN
USA

- Quick, sure below hook drum handling by one person
- Hand operated geared tilt
- 360° drum tilt control in both directions
- Save time, reduce waste, improve productivity
- Efficient, controlled high level pouring
- Capacity: 2500 Lb. (1134 kg)

Morse Manual Drum Tilt Kontrol-Karrier

Model 185XGR has a pull chain and chain wheel for manual drum tilt control with a 12' (366 cm) loop of chain. There is enough resistance in the enclosed gear box to automatically stop and hold the drum tilt angle. Hand wheel tilt control option is also available.

Extra-heavy-duty construction with steel tube framework, large shafts and bearings offer long life in tough service. The oil filled, worm gear speed reducer provides 150:1 gear reduction for fine control when tipping heavy drums.

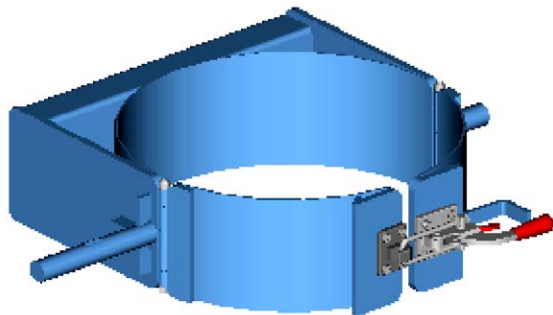

The 3-Piece Drum Holder with 2 hinged metal bands and a clamp in the front is sized for your standard ribbed 55-gallon (210 liter) 22.5" (57.2 cm) diameter steel drum.

Model 185XMGR adds [spark resistant parts](#) to reduce the possibility of mechanical sparks.

Ships fully assembled.

Full Drum Capacity 2500 Lb. (1134 kg) Half-full drum capacity is 1250 Lb. (567 kg) Half-full rating is an indication of capacity for tilting an unbalanced, bottom-heavy drum. A partially full drum with unbalanced and shifting load is harder to tilt than full drum.

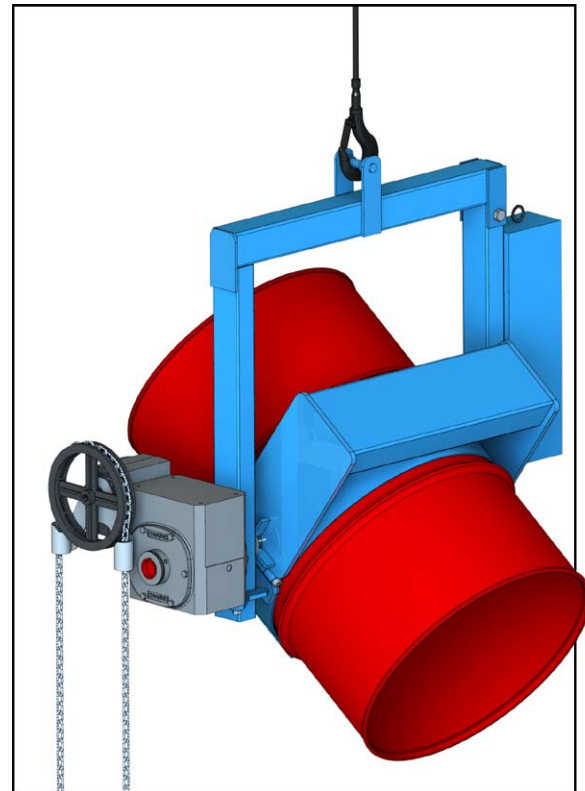

Steps for use of Super-Duty Kontrol-Karrier

1. Attach your hoist hook to lifting point. Lift and move the Kontrol-Karrier to your upright drum.
2. Mate the Kontrol-Karrier's drum holder to the middle of your drum and secure your drum between drum ribs... no tools are needed.
3. Pull down one side of the chain loop while letting out the other to turn your drum. Chain loop provides control of drum tilt 360° in either direction, even while drum is hoisted above your reach.

| Model # | Description | 19" Diameter Adapter | Unit Weight |
|----------------|--|----------------------|------------------|
| 185XGR | Kontrol-Karrier with 3-piece drum holder, 2500 Lb. Capacity | Model 55/30-19GR | 404 Lb. (183 kg) |
| 185XMGR | Kontrol-Karrier with spark resistant parts, 3-piece drum holder, 2500 Lb. (1134 kg) Capacity | None | 404 Lb. (183 kg) |

Options & Accessories

Option # X03-185XGR

Factory installed 8" (20.3 cm) Diameter Hand Wheel with speed handle.
Replaces standard chain wheel to turn the drum.



Model 55/30-19GR

Diameter Adapter for a 19" (48.3 cm) diameter 30-gallon (114 liter) steel drum. Simply insert the Diameter Adapter into the drum holder.

Lift it back out to go back to handling a 55-gallon (210 liter) steel drum.

Fork Pocket Kit # 6333-P

Add fork pockets to below-hook drum handler.
Install on model 185A-GR, 185XGR or on 195 Series.
NOT for model with spark resistant parts.

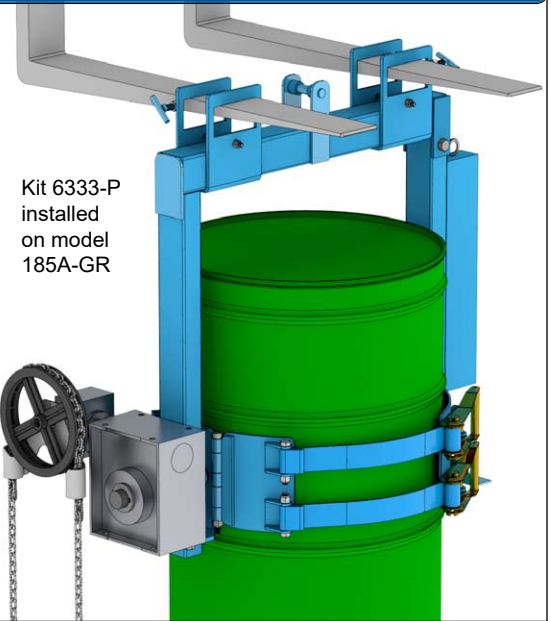

Kit 6333-P installed on model 185A-GR

MADE IN USA

Dimensions

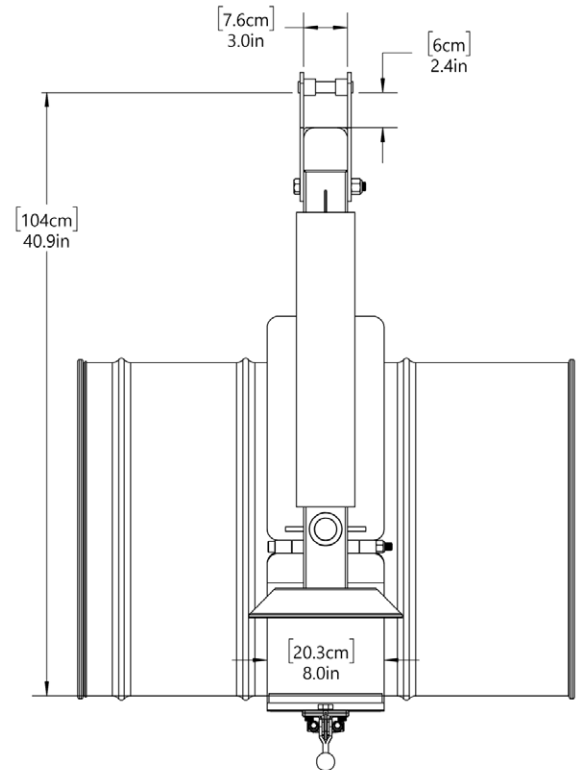
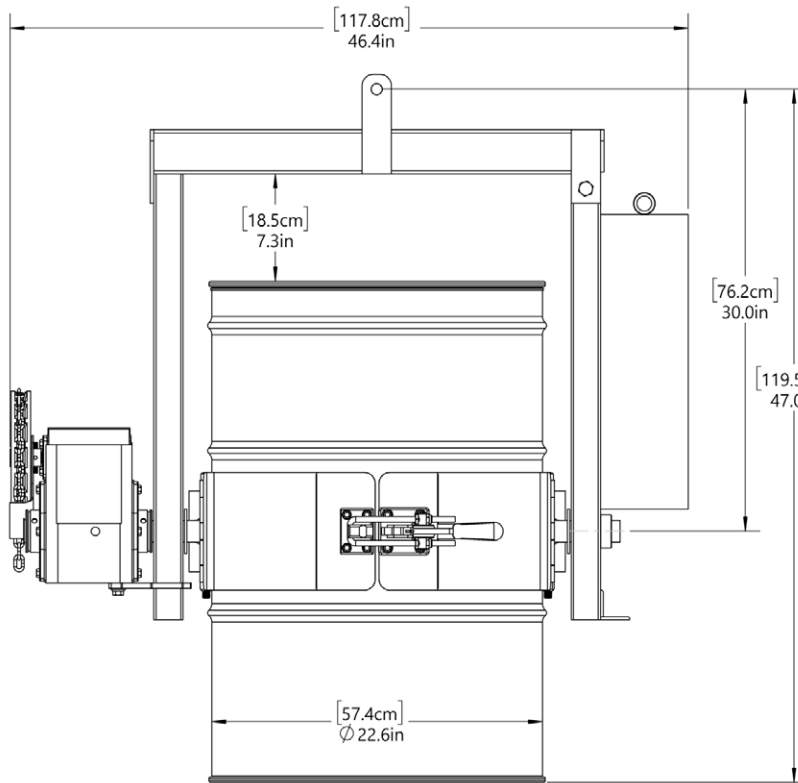

NOTE: Standard loop of pull chain extends approximately 6 feet (1.8 m) below the chain wheel