

- Thorough “corner-over-corner” mixing action
- Saves time, labor and money
- Use a separate drum for each batch
  - No container to purge between batches
  - Common drums make economical vessels



>> Watch the Video <<

MADE  
IN  
USA



**Model # 309-3 Drum Tumbler™**  
shown with Control Package  
Option # CP-309-3-230 (sold separately)



**Model # 309-3 Drum Tumbler™**



**Model # 309-3 Drum Tumbler™**  
shown with Control Package  
Option # CP-309-3-230 (sold separately)

## Tumble a Closed Plastic, Steel or Fiber Drum

- Mix products inside a drum  
29” to 37” (74 to 94 cm) tall  
18” to 23.5” (46 to 60 cm) diameter
- Capacity:  
800 Lb. (363 kg) Full Drum  
400 Lb. (181 kg) Half-Full Drum

Half-full Capacity is an indication of the capacity for tilting an unbalanced, bottom-heavy drum. A partially full drum with an unbalanced and shifting load is harder to tilt than a full drum.

### Mixing in a Closed Drum Means Less Hazards

Enjoy the benefits of mixing inside closed shipping drums. Eliminate worker exposure to dangerous ingredients, spills and risk of contamination. Mix right inside a sealed drum with a Morse Drum Tumbler™.

Load an upright drum with your hoist or crane



Open the hinged ratchet plate and two top clamps, then load a drum into the tumbler with [model 92 Below-Hook Drum Lifter](#) and your hoist or crane.

Or with your forklift, [model 284 Fork Hook](#), and [model 92 Below-Hook Drum Lifter](#) (inset).

Secure your drum in holder with web strap and two top clamps



Secure the drum in the tumbler using the web strap and ratchet around the drum, and tightening the two top clamps. Then turn the motor on to begin drum tumbling.

## Control Packages (Sold Separately)

Morse Control Packages include the Control Mast and the appropriate Control Box for each model. Use power controls to start and stop drum tumbling. Position the control mast outside the safety enclosure on either the left or right side, or at the back of Drum Tumbler.

### Control Mast and AC Control Box for Model 309-1 NEMA 4/12 for NON-Hazardous Areas

Includes Control Mast and Control Box with:

- Fixed Drum Rotation Speed at 14 RPM
- Timer adjusts from a few seconds to 16 hours
- Start and Stop Buttons
- Red Emergency Stop Button
- Lockable Main Disconnect to shut off and lock out power to the unit
- Wire terminals for external connection of safety interlock switch



### Control Mast and AC Control Box for Model 309-3 NEMA 4/12 for NON-Hazardous Areas

Includes Control Box with:

- Variable Speed Drum Rotation from 2 to 20 RPM
- Timer adjusts from a few seconds to 16 hours
- Start and Stop Buttons
- Red Emergency Stop Button
- Lockable Main Disconnect to shut off and lock out power to the unit
- Wire terminals for external connection of safety interlock switch



### Control Mast and Explosion Proof AC Control Box NEMA 7/9 for Hazardous Areas

Includes Control Mast and Explosion-Proof Control Box with:

- Fixed Drum Rotation Speed at 14 RPM (12 RPM on 50Hz models)
- Start and Stop Buttons
- Run / Jog Selector Switch
- Wire terminals for external connection of safety interlock switch



## Guard Enclosure Kits (Sold Separately)

### Enclosures with Safety Interlock to Meet OSHA Requirements



Install all Morse Rotators in accordance with local requirements for enclosure and safety interlock, etc. One way to accomplish this is with a Morse enclosure with safety interlock, so the rotator automatically turns off when enclosure door is opened. Power connections and motor controls must also comply with applicable local codes.

For OSHA compliance in the USA, see OSHA subpart O.1910.212(a)(4) "Barrels, containers, and drums. Revolving drums, barrels, and containers shall be guarded by an enclosure which is interlocked with the drive mechanism, so that the barrel, drum, or container cannot revolve unless the guard enclosure is in place."

Enclosure outside post-to-post dimensions:  
L76" x W52" x H63.25" (193 x 132 x 161 cm)

### Control Mast and Air Controls are Included with Model 309-A

Air Controls Include

- Filter, Regulator and Lubricator (FRL)
- On / Off Valve



MADE IN USA

Drum Tumbler™ Model Numbers														
Model #	Motor Style	HP	Phase	Motor Voltage	Hertz	Amp Draw	Drum RPM	Domestic Ship Weight	Domestic Ship Dimensions	Control Package Option #	Guard Enclosure Kit Option #			
309-1	TEFC	1	1	115	60	12.8	14	638 Lb. (290 kg)	L72" x W42" x H46" (183 x 107 x 117 cm)	5996-P	GEK-309-3			
				208		7.0				5997-P				
				230		6.4				5997-P				
309-3	Inverter-Duty	1	3	230/460	60	2.8	14 RPM or Variable Speed 2 to 20 RPM with Morse Control Package					CP-309-1-115 *	GEK-309-3	
						2.8						CP-309-1-230 *		
						2.8						CP-309-3-230 *		
						1.4						CP-309-3-460 *		
309-E1	Explosion proof **	1	1	115/230	60	13	14				CP-309-E1-115 *	GEK-309-E1		
					6.5									
309-E1-50	Explosion proof **	1	1	110/220	50	6.2	12				CP-309-E1-220-50 *	GEK-309-E1		
309-E3	Explosion proof **	1	3	208	60	3.1	14						CP-309-E3-230 *	GEK-309-E3
				230		3.0							CP-309-E3-230 *	
				460		1.5		CP-309-E3-460 *						
309-E3-50	Explosion proof **	1	3	230/400	50	3.5	12	CP-309-E3-230-50 *	GEK-309-E3					
				2.0										
309-E3-575	Explosion proof **	1	3	575	60	1.2	14	CP-309-E3-575 *	GEK-309-E3					
309-A	Air Motor ***	-	-	-	-	-	14 (Vary with air flow & pressure)						On/Off Air Valve, Filter, regulator, lubricator included with 309-A ***	GEK-309-A

\* **ONLY NON-Explosion Proof** AC Control Packages include a pre-wired control box. Models with explosion proof Control Packages have no wiring from the NEMA 7/9 control box to the motor. Please consult an electrician to complete the wiring in accordance to your local code.

\*\* Explosion Proof motors on models 309-E1 and 309-E1-50 are rated for Class 1 Group D. Other Explosion Proof motors are rated for Class I Group D, and Class II Groups F and G.

\*\*\* **Air Controls included with model 309-A**  
Includes: On / Off Air Valve, and Filter, Regulator, Lubricator (FRL)

Air powered model requires plant air at 40 to 60 psi and flowing at a rate of 40 scfm. Air Powered Drum Tumbler (model 309-A) rotates a drum at 14 RPM and allows you to vary RPM with air flow and pressure. Sound level during operation is about 75 db.



Model #	Fully Enclosed Export Crates - Heat Treated and IPPC Compliant	Ship Weight Adder	Ship Dimensions
5979X-P	Export Drum Tumbler (with or without Control Package)	200 Lb. (91 kg)	L57" W35" H56" (145 x 89 x 142 cm)
5980X-P	Export Drum Tumbler, Control Package and Guard Enclosure Kit	480 Lb. (218 kg)	L78" W47" H69" (198 x 119 x 175 cm)

Base Dimensions

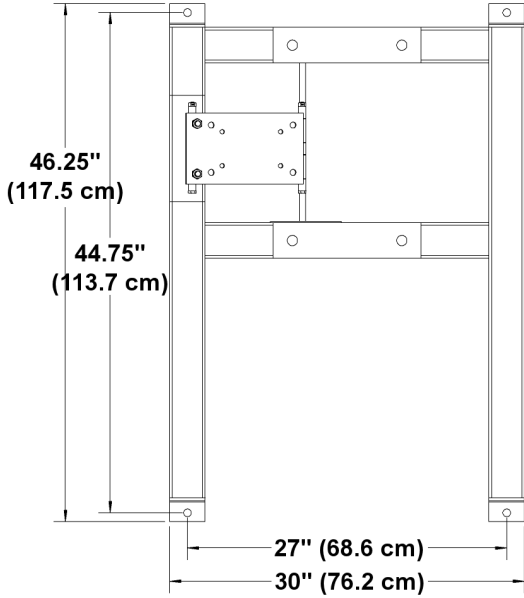

Top View

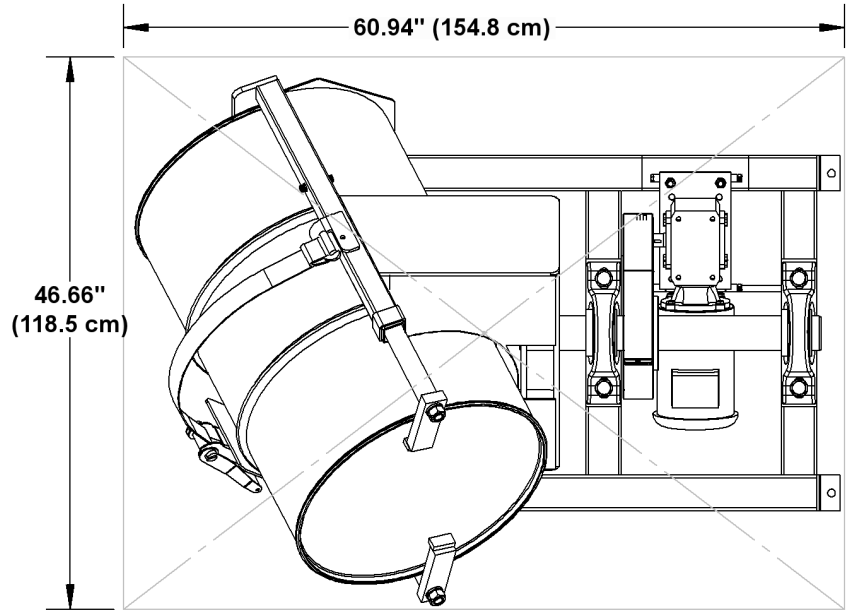

End View

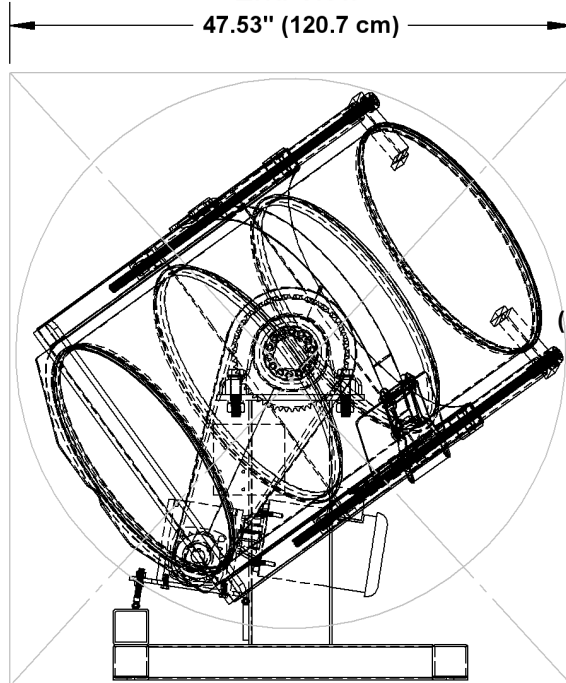

Side View

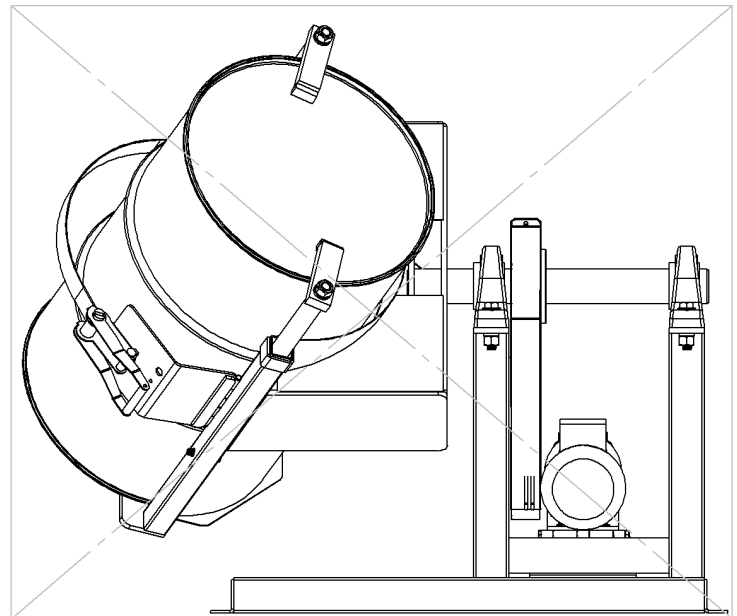

MADE  
 IN  
 USA