

Lift and Dispense up to a 1200 Lb. (544 kg) Drum

>> Click to Watch Video <<

MADE
IN
USA

- You Control Lifting Height and Pouring Angle
- Removes Effort and Increases Productivity
- Models with Power Lift and Tilt
- Heavy-Duty Hydraulics
- 360° Tilt Control in Either Direction
- Capacity: 1200 Lb. (544 kg) full drum (600 Lb. (272 kg) half-full* drum)
- Available with Spark Resistant Parts

A fully loaded drum is easily handled by one person with a Morse Heavy-Duty Hydra-Lift Karrier. Lift, move and control pouring of a 55-gallon (208 liter) steel drum weighing up to 1200 Lb. (544 kg) with minimal physical effort. Maximum pouring height is 72" (183 cm). Handle a variety of other drums by installing the correct MORCINCH™ options for your particular size and type of drum.

You raise and control dispensing as necessary. Increase pouring angle for full discharge, reduce to control the pour rate, or reverse to stop pouring and deliver partial drum contents.

Material is discharged straight forward directly from the drum. Faucets, pipe, valve extensions may be attached to the drum. The ability to control pouring straight from the drum with variable lift and pour angles is an important difference from chute type dumpers.

Though often used for lifting and pouring, the Hydra-Lift Karrier can be used in various ways, such as lifting drums on or off scales, platforms, conveyors or trucks, moving drums to or from storage, charging high tanks and positioning drums of parts for hand access at work stations.



Model 410-110 with 72" (183 cm) dispensing height and electric power lift and tilt.

Each Heavy-Duty Hydra-Lift Karrier Features

Dual Heavy-duty hydraulic cylinders with a built-in flow control for a uniform, controlled speed of descent with even the heaviest drum. Heavy duty hydraulic lift cylinders include a velocity fuse to provide a full line shut-off in the event of a line failure.

Welded rectangular steel tube framework.

Easy maneuverability on four 4" (10.2 cm) nylon swivel casters under the base.

Step-down floor lock.

MORCINCH Drum Handling System

- Automatically adjusts for 22" to 23.5" (56 to 59.7 cm) diameter drum
- Accepts Diameter Adaptors for your smaller drum
- Accepts bolt-on Top Rim Clamp or Bracket Assembly to handle a plastic or fiber drum
- Includes a flexible cover on the cinch chain to help protect the sidewall of your drum
- Incorporates alloy cinch chain and hinge, and durable stress relief weld joints



Power Lift and Tilt Models are available with electric, air or battery power lift and tilt.

Power Lift, Manual Tilt Models

have electric, air or battery power lift, but a pull chain and chain wheel for drum tilt control. Covered tilt gears with 60:1 reduction make pouring your drum simple and easy.



Manual Lift and Tilt

Models have a hydraulic hand pump with variable release valve for drum lift, and pull chain and chain wheel drum tilt control.

Option X02-410

Factory installed Hand Crank on 410 Series with manual tilt control. Replaces pull chain tilt control.



Option X03-410

Factory installed 16" (40.6 cm) Diameter Hand Wheel (not shown) on 410 Series with manual tilt control. Replaces pull chain tilt control.

MORStop Tilt-Brake

The MORStop Tilt-Brake is factory installed on all manual tilt models to automatically hold the drum tilt angle, even if the drum's contents shift suddenly.

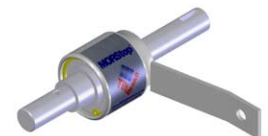

Model #	Description	Domestic Ship Weight
410-110	AC Power Lift and Tilt	560 Lb. (255 kg)
410-114	Air Power Lift and Tilt	550 Lb. (250 kg)
410-115	DC Power Lift and Tilt	600 Lb. (273 kg)
410-120	AC Power Lift, Manual Tilt	536 Lb. (244 kg)
410-124	Air Power Lift, Manual Tilt	515 Lb. (234 kg)
410-125	DC Power Lift, Manual Tilt	569 Lb. (259 kg)
410	Manual Lift and Tilt	499 Lb. (227 kg)
410M-114	Air Power Lift and Tilt with Spark Resistant Parts	550 Lb. (250 kg)
410M-124	Air Power Lift, Manual Tilt with Spark Resistant Parts	515 Lb. (234 kg)
410M	Manual Lift and Tilt with Spark Resistant Parts	499 Lb. (227 kg)

* Half-full rating is based on tilt mechanism's capacity for handling a bottom heavy drum. A partially full drum with unbalanced and shifting load is harder to tilt than a full drum.



morsedrum.com



service@morsedrum.com



(315) 437-8475



103 Kuhn Rd.
Syracuse, NY, 13208 USA

Models with Power Lift and Tilt

Power Lift and Tilt makes drum handling easier and faster. There are two hand valve controls: One for the power-lift function and a second for power-tilt.

Model #	Motor Type	Motor Control
410-110	AC, 1HP/115V, TEFC	Switch, Cord, Plug
410-114	Air, Vane Type	On/Off Valve
410M-114	Air, Vane Type	On/Off Valve
410-115	DC, 12V	Built-in

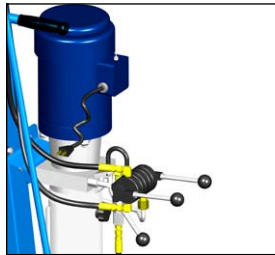

Electric Power Lift & Tilt

Hold momentary switch and lift valve to raise drum. Use second valve to control the hydraulically driven drum tilt. Lower the drum with manual release valve.

UL listed motor with 12.8 full amp draw.

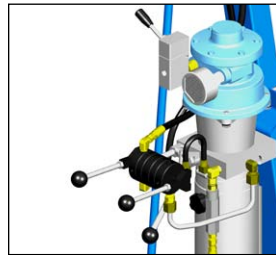

Air Power Lift and Tilt

Hold on/off valve and lift valve to raise the drum. Use a second valve to control the hydraulically driven drum tilt. Lower the drum with manual release valve. Air motor Requirements: 40 to 60 PSI at 40 SCFM.

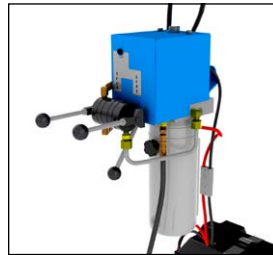

Battery Power Lift and Tilt

Self contained battery power-lift. Hold momentary switch and lift valve to raise drum. Use second valve to control the hydraulically driven drum tilt. Lower the drum with manual release valve. Separate charger is included.

MORCINCH™ Options

The MORCINCH™ drum holder on Hydra-Lift Karriers is designed to handle a 55-gallon (208 liter) steel or fiber drum. It automatically adjusts from 22" to 23.5" (56 to 59.7 cm) in diameter. The cinch chain with pawl and ratchet mechanism is used to secure the drum in the holder. To handle other drums, order one of the following:

The **Bracket Assembly** provides a brace at top and bottom of your drum to prevent it from slipping lengthways through the drum holder. The Bracket Assembly is required to handle a rimless plastic drum, and recommended to more securely handle a fiber drum. It adjusts for 31" to 39" (79 to 99 cm) tall drum.

Part # 4556-P Bracket Assembly.
Part # 4556M-P Spark Resistant Bracket Assembly.



MADE IN USA

The **Top Rim Clamp** grips the upper rim of your drum to prevent it from slipping through the drum holder. Use to handle a 55-gallon rimmed plastic or fiber drum. To handle a 55-gallon plastic drum with top rim, you must install either the Bracket Assembly or the Top Rim Clamp.

Part # 4560-P Rim Clamp Assembly.
Part # 4560M-P Spark Resistant Rim Clamp Assembly.



Web Strap with Ratchet



MORCINCH™ Drum Holder with Option # 5115i-P Web Strap and Ratchet installed (not for spark resistant models)

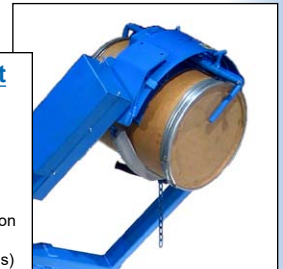

For a smaller diameter drum, **Diameter Adaptors** install easily without tools and are quickly removed. Diameter Adaptors for 17.5" (44.5 cm) diameter or smaller have brackets at top and bottom of the drum. They adjust for a drum up to 38" (96.5 cm) tall. Spark resistant and stainless steel Diameter Adaptors are also available.

Models with Power Lift and Manual Tilt

Power-Lift models ease drum lifting, but retain manual tilt control.

Model #	Motor Type	Motor Control
410-120	AC, 1HP/115V, TEFC	Switch, Cord, Plug
410-124	Air, Vane Type	On/Off Valve
410M-124	Air, Vane Type	On/Off Valve
410-125	DC, 12V	Built-in



Electric Power Lift

Use switch to raise the drum. Lower the drum with manual release valve.

UL listed motor with 12.8 full amp draw.

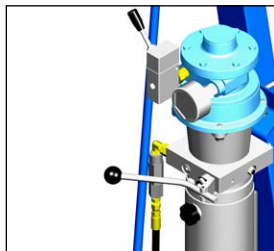

Air Motor Power Lift

Use on/off valve to raise the drum. Lower the drum with manual release valve. Air motor Requirements: 40 to 60 PSI at 40 SCFM.

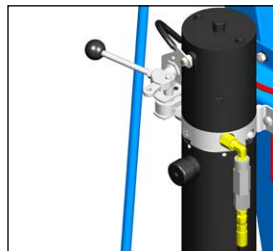

Battery Power Lift

Self contained battery power-lift. Use valve to raise and lower the drum. Separate charger is included.

NOTE: 12V Deep Cycle Lead Acid Battery is designed for domestic shipment only. For export shipment, choose the following battery option:

- Option "NB" No Battery. Customer must obtain battery before use... Exide # 27MDP 12V Deep Cycle Battery or equivalent.

DIAMETER ADAPTORS

DIAMETER ADAPTORS	SPARK RESISTANT DIAMETER ADAPTORS	STAINLESS STEEL DIAMETER ADAPTORS	FITS DIAMETER	DOMESTIC SHIP WEIGHT
55/30-20.5	55/30M-20.5	55/30SS-20.5	20" to 20.5" (50.8 to 52.1 cm)	20 Lb. (9 kg)
55/30-19	55/30M-19	55/30SS-19	18.5" to 19" (47 to 48.3 cm)	24 Lb. (11 kg)
55/30-17.5	55/30M-17.5	55/30SS-17.5	17" to 17.5" (43.2 to 44.5 cm)	35 Lb. (16 kg)
55/30-16	55/30M-16	55/30SS-16	15.5" to 16" (39.4 to 40.6 cm)	35 Lb. (16 kg)
55/30-14.5	55/30M-14.5	55/30SS-14.5	14" to 14.5" (35.6 to 36.8 cm)	36 Lb. (16 kg)

Optional 3-Piece Drum Holder

Option # G-400

The optional 3-Piece Drum Holder is for handling only a 22.5" (57 cm) diameter 55-gallon (208 liter) steel drum. It surrounds your drum with a hinged metal band.



Dimensions

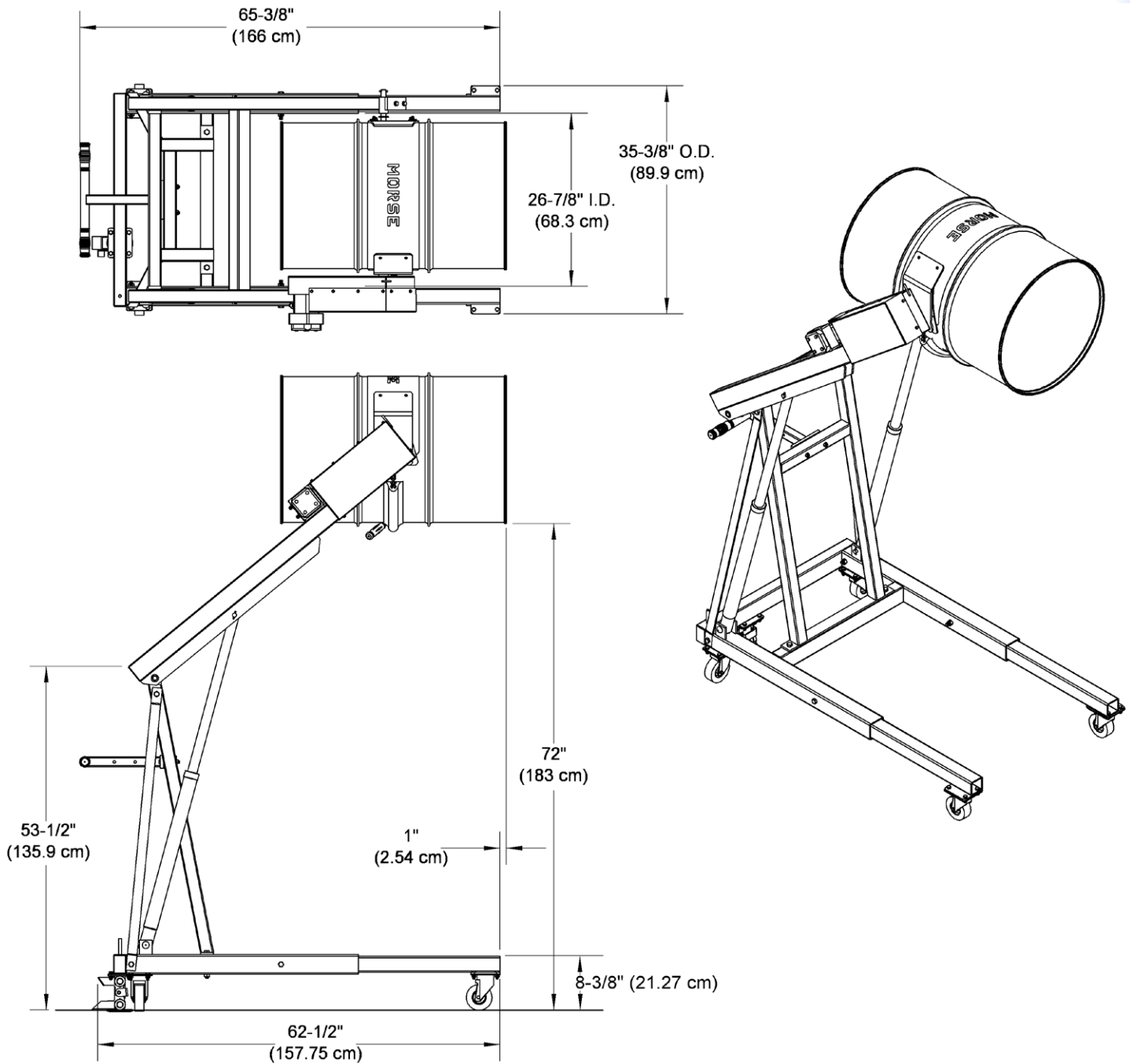

MADE
IN
USA