

Ergonomic Dispensing of 5-Gallon Cans or Pails

- Control dispensing from your heavy 5-gallon (19 liter) cans or pails weighing up to 75 Lb. (34 kg)
- Increase employee safety
- Reduce spills of valuable contents and environmental contamination

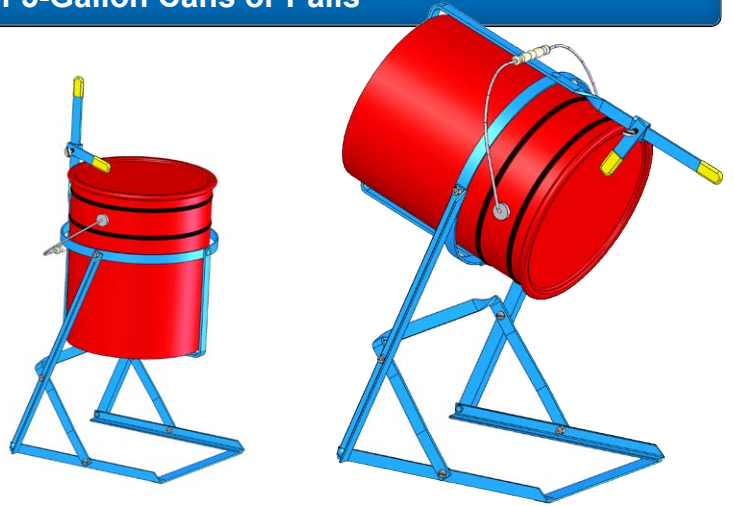

Model 15 Can Tipper

Model 15 handles a 5-gallon (19 liter) can or pail. A safety lock holds the pail in the holder.

Dispensing height is 10" (25 cm).

Handle a can up to 12.25" (31.2 cm) in diameter, and from 10" to 19" (25.4 to 48.3 cm) tall.

Capacity: 75 Lb. (34 kg).

It folds for easy storage.



Model 2-15 Double Can Tipper

Model 2-15 Double Can Tipper handles one or two 5-gallon (19 liter) cans or pails. Dispense from either can.

Top pail dispenses at 34" (86 cm) high.

Ring of top pail holder is 43" (109 cm) high

Handles two 5-gallon (19 liter) cans or pails up to 12.25" (31.2 cm) in diameter, and from 10" to 19" (25.4 to 48.3 cm) tall.

Capacity: 75 Lb. (34 kg) per can.



Model 15-SS Stainless Steel Can Tipper

Model 15-SS is the same as model 15, but made of type 304 stainless steel.

Model #	Description	Handles	Domestic Ship Weight	Domestic Ship Dimensions
15	5-Gallon Can Tipper	1 5-Gallon (19 liter) Pail on Can	8 Lb. (3.6 kg)	L23" W15" H3" (59 x 38 x 8 cm)
2-15	Double 5-Gallon Can Tipper	1 or 2 5-Gallon (19 liter) Pails or Cans	19 Lb. (8.6 kg)	L42" W16" H7" (107 x 41 x 18 cm)
15-SS	Stainless Steel Can Tipper	1 5-Gallon (19 liter) Pail on Can	9 Lb. (4 kg)	L23" W15" H3" (59 x 38 x 8 cm)

MADE
IN
USA

Dimensions: Models 15 and 15-SS

Dimensions: Model 2-15

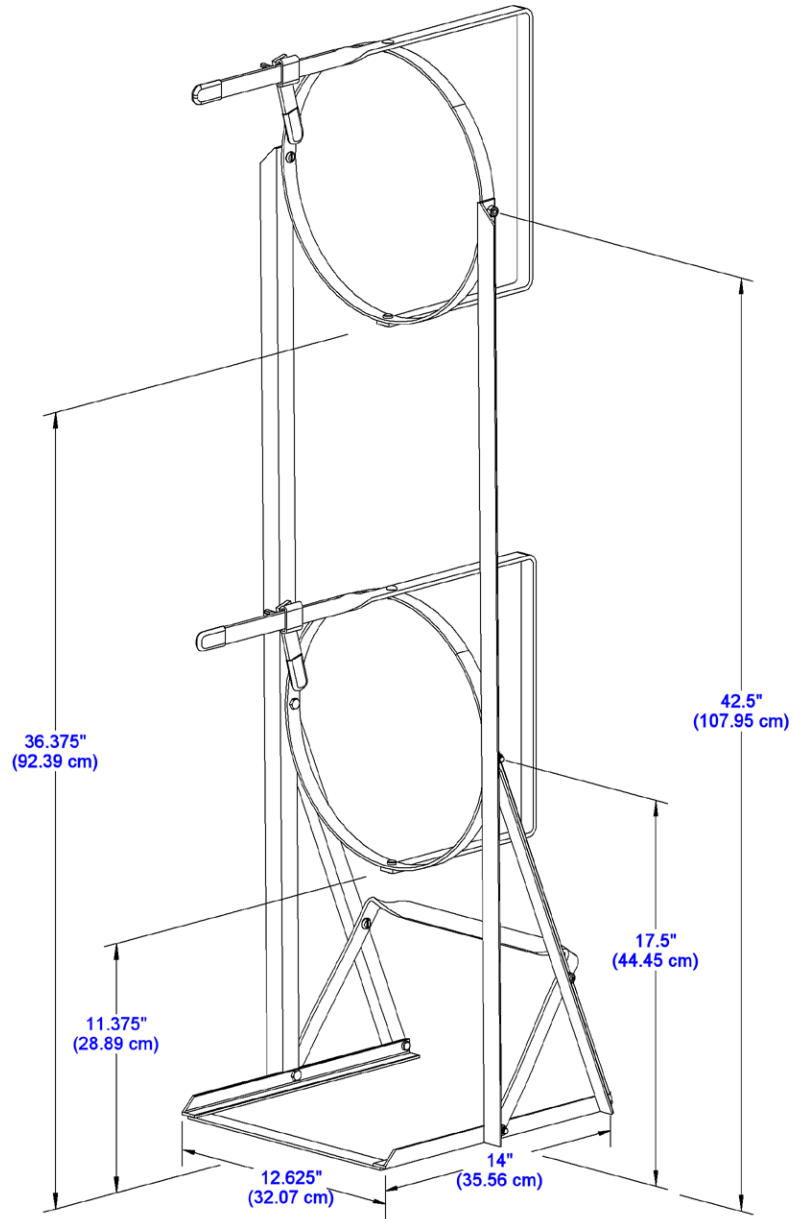
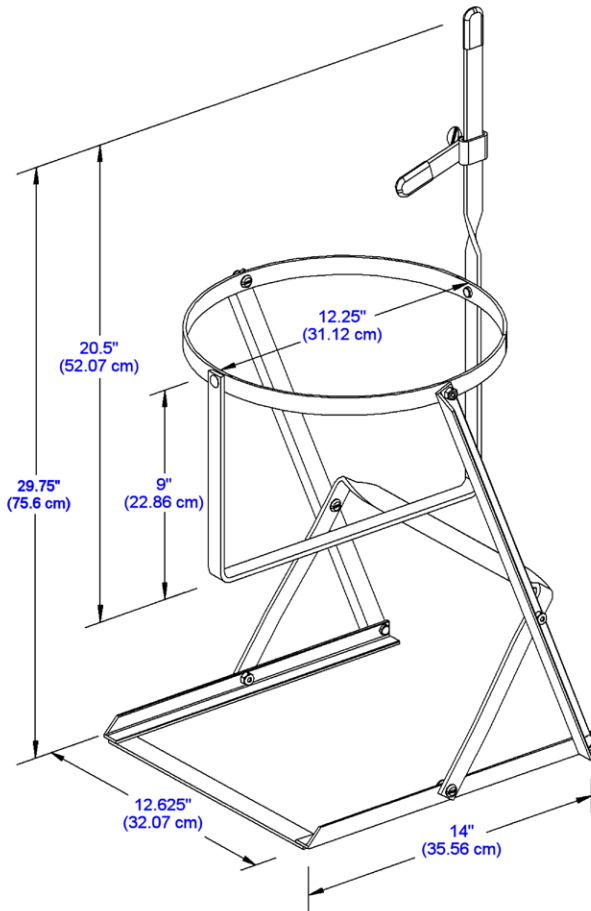

MADE
IN
USA

Please contact your Morse dealer