



MORSE 

185A-HD SERIES

SPECIFICATIONS SHEET

HEAVY-DUTY KONTROL KARRIERS

Models 185A-HD, 185AM-HD & 185A-HDSS

Lift And Dispense A Drum With Your Hoist Or Crane

- Provides controlled high-level pouring
- Allows 360° drum tilt control in both directions with pull chain control with 30:1 gear ratio and gear covers
- Handle drum with faucet in place
- Stands upright on foot support
- Capacity: 800 Lb. (363 kg) full drum
500 Lb. (227 kg) half-full drum capacity.
Half-full capacity is an indication of the capacity for an unbalanced, bottom-heavy drum. A partially full drum with an unbalanced and shifting load is harder to tilt than a full drum.
- Model 185AM-HD has spark resistant parts

Morse Kontrol-Karriers have a 12' (3.6 m) long pull chain loop with 6' (1.8 m) drop so you control drum tilting, 360° in either direction. Dispense a drum overhead with your crane or hoist. Order with Hand Crank or Hand Wheel option for use only within reach of operator.

We recommend the MORStop Tilt-Brake™ option to automatically hold the drum tilt angle until you move it. This prevents a partially full, unbalanced drum from turning out of control, even when the contents shift from one end to the other.



Stainless Steel Model 185A-HDSS

The frame and drum holder band are made of finished type 304 stainless steel ideal for food or pharmaceutical application where regular wash down is required. Welds are NOT ground smooth or polished. Some purchased parts are NOT stainless, such as ratchet and pawl. Gears and sprockets are NOT stainless, but covered with plastic guards.



KONTROL-KARRIERS			FACTORY INSTALLED OPTIONS				
MODEL	DESCRIPTION	TILT CONTROL	MORSTOP TILT-BRAKE	HAND CRANK	HAND WHEEL	WEB STRAP & RATCHET	COUNTER WEIGHT
185A-HD	Standard	Chain Wheel	3900i-P	X02-185	X03-185	5115i-P	4622i-P
185AM-HD	Spark Resistant Parts	Chain Wheel	3900i-P	X02-185M	X03-185M	5115Mi-P	4622i-P
185A-HDSS	T304 Stainless Steel	Chain Wheel	3900SSi-P	X02-185HDSS	X03-185HDSS	5115SSi-P	4622SSi-P



Standard MORCINCH Drum Holder has Cinch Chain and Ratchet with flexible chain cover



OPTION 5115i-P Web Strap & Ratchet

MORCINCH DRUM HANDLING SYSTEM

Morse 185A-HD Kontrol Karriers feature the MORCINCH™ Drum Handling System Manual-grip drum holder automatically adjusts for 22" to 23.5" (56 to 597 mm) diameter drum.

ACCESSORIES

Diameter Adapters

for Smaller Diameter Drums

Diameter Adapters insert into the drum holder to handle a smaller drum. Select the correct size Diameter Adapter for each drum. Spark resistant and stainless steel Diameter Adapters also available.

Model 55/30-19 and 55/30SS-16

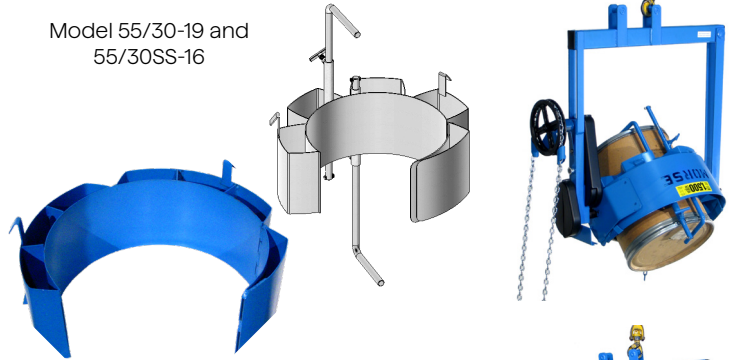

Bracket Assembly

for Rimless Plastic or Fiber Drums

The Bracket Assembly provides a brace at top and bottom of your drum to prevent it from slipping lengthways through the drum holder. The Bracket Assembly is required to handle a rimless plastic drum, and recommended to more securely handle a fiber drum. It adjusts for 31" to 39" (79 to 990 mm) tall drum.

- Kit 4556-P Bracket Assembly
- Kit 4556M-P Spark Resistant
- Kit 4556SS-P Stainless Steel



Top Rim Clamp

for Rimmed Plastic or Fiber Drums

The Top Rim Clamp grips the upper drum rim to prevent it from slipping length-ways. Install it to safely handle a 30-gallon to 55-gallon (114 to 210 liter) size plastic or fiber drum.

- Kit 4560B-P Rim Clamp Assembly
- Kit 4560BM-P Spark Resistant
- Kit 4560BSS-P Stainless Steel



INSTALLED OPTIONS

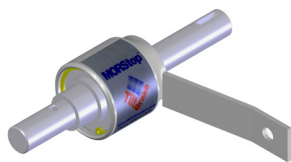

We recommend MORStop Tilt-Brake factory installed on your Kontrol-Karrier to automatically hold the drum tilt angle.



9" (230 mm)
Hand Crank
Option X02-185



16" (406 mm)
Hand Wheel
Option X03-185

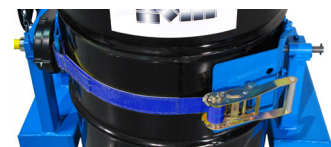

- Web Strap and Ratchet
- Option 5115i-P Web Strap & Ratchet
- Option 5115Mi-P Spark Resistant
- Option 5115SSI-P Stainless Steel



185A-HD SERIES

Kontrol Karriers

SPECIFICATIONS SHEET

KITS FOR CUSTOMER INSTALL ON EXISTING UNITS

MODEL	MORSTOP TILT-BRAKE	HAND CRANK	HAND WHEEL	WEB STRAP & RATCHET	COUNTER WEIGHT KIT	FORK POCKETS
185A-HD	3900-P	1460-P	2690-P	5115-P	4622-P	6315-P
185AM-HD	3900-P	1460M-P	2690M-P	5115M-P	4622-P	None
185A-HDSS	3900SS-P	1460SS-P	2690SS-P	5115SS-P	4622SS-P	None

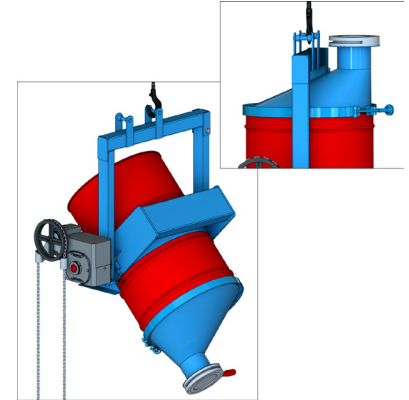
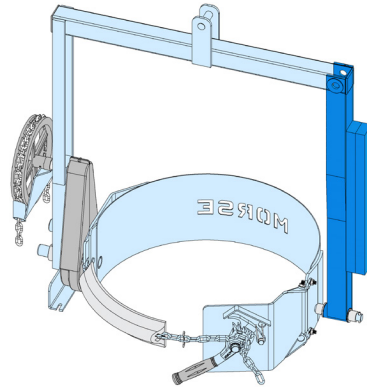

Fork Pocket Kit 6315-P

Add fork pockets to below-hook drum handler. Install on model 85A, 85G, 85i, 86, 185A, 185G, 185A-HD or 185G-HD. NOT for model with spark resistant parts.

Counterweight

Keeps your Kontrol-Karrier hanging plumb, even without a drum in the holder. Option 4622i-P Factory Installed Kit 4622-P For customer to install

Asymmetric Drum Cones

Attach an Asymmetric Drum Cone with iris valve or slide gate to your drum to start and stop material flow as needed.

Steps For Use of Morse Heavy-Duty Kontrol-Karriers

1. Attach the off-center lifting point of the Kontrol-Karrier to your hoist hook, then move to your upright drum.
2. Mate the Kontrol-Karrier's drum holder to the middle of your drum.
3. Secure drum holder to your drum between drum ribs - no tools are needed. To secure drum, drape the cinch chain with flexible chain cover across the front of the drum, insert one link into the slot on the ratchet handle, and turn the ratchet handle clockwise to tighten the cinch chain around the drum.
4. Tighten the Top Rim Clamp or adjust the Bracket Assembly height, if your Heavy-Duty Kontrol-Karrier is so equipped.
5. Transfer you hoist hook to the centered lifting point.
6. Lift the Heavy-Duty Kontrol-Karrier and secured drum, with your hoist or crane.
7. To control turning of your drum, pull down on one side of the pull chain loop while letting out the other.
8. To remove drum from your Heavy-Duty Kontrol-Karrier, turn the ratchet handle clockwise to relieve pressure on the ratchet teeth, lift pawl handle to release teeth engagement, then rotate the ratchet handle counter clockwise to loosen the chain and allow its removal from the slot on the ratchet handle.





185A-HD SERIES

Kontrol Karriers

SPECIFICATIONS SHEET

DIMENSIONS

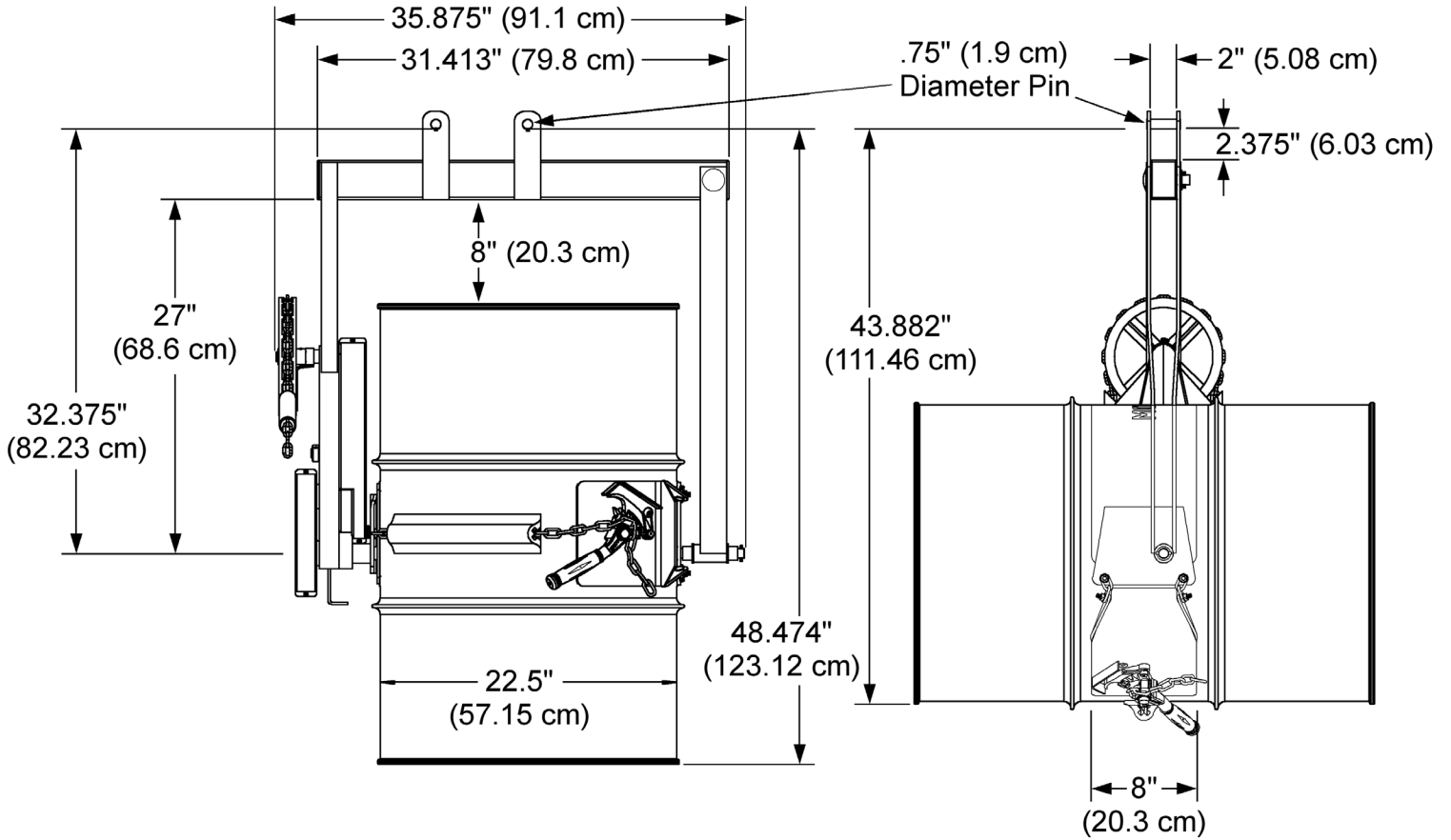

NOTE: Standard loop of pull chain extends approximately six feet below the chain wheel



Custom Drum Handler

Custom model 185S-HD-FP handles drum completely below the forks or below-hook

Use with:

- Walkie Stacker
Requires 17-7/16" (443 mm) between forks
- Forklift
- Crane or Hoist below-hook

