

MORSE 

82H-XR SERIES

SPECIFICATIONS SHEET

EXTENDED REACH PALLETIZERS

82H-XR Series Goes Further Than Before

The 82H-XR Series drum handler is designed to deliver enhanced versatility and performance for a wide range of industrial applications. With an extended reach, this model allows for easy access to drums on pallets, spill containment, cabinets, and other hard-to-reach areas.

Whether you need to move drums onto and off pallets or store them in confined spaces, the 82H-XR provides a reliable and efficient solution. Its mechanical drum grip ensures secure handling of various drum types, making it ideal for operations requiring consistent, safe drum manipulation.

- Extended reach drum handler to access drum on pallet, spill containment, cabinet, etc.
- Raise a 34-7/8" (886 mm) tall drum up to 19" (483 mm) above the floor
- Efficiently move upright drum onto and off pallets and floor
- Bottom of drum is held 4" (101.6 mm) beyond the front wheels
- Handle virtually any **rimmed** steel, fiber or plastic drum - tight head or securely clamped top in place
- Completely mechanical automatic drum grip
- Handle drums size various starting at 22.5" (571.5 mm) tall
- Requires 50 Lb. (22.7 kg) minimum drum weight to activate jaws
- Easy maneuverability on 6" (152.4 mm) rear casters and 8" (203.2 mm) front wheels
- Step-down floor lock to hold in place
- 24" (609.6 mm) wide base to fit in tighter areas
- Rear counterweight for stability
- Capacity: 600 Lb. (272 kg)





82H-XR SERIES

Extended Reach Drum Movers & Palletizers

SPECIFICATIONS SHEET

82H-XR Series Models

MODEL #	DRUM HOLDER	FEATURES	MOTOR TYPE	MOTOR CONTROL
82H-XR-125	Jaws and brace on sidewall	Battery Power Lift *	12V DC *	Built-in
* 12V DC Power Lift includes 12V deep cycle battery, and 100/220V 50/60Hz AC charger.				



Extra Attention to Detail

- 12V DC Battery Power Drum Lift with wired 2-button pendant
- Battery disconnect switch to power on/off
- Battery charge level display
- Convenient panel mounted charger plug
- Includes battery and charger
- Hydraulic power unit is protected in enclosed box

Enclosed Components

- 12V DC Battery Power Drum Lift with wired 2-button pendant
- Battery disconnect switch to power on/off
- Battery charge level display
- Convenient panel mounted charger plug
- Includes battery and charger
- Hydraulic power unit is protected in enclosed box

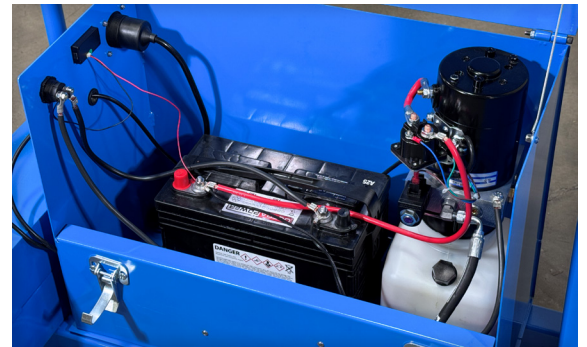

Grab, lift and move drum in minimum time with this efficient drum handler.

Drum gripping jaws in the “head” provide automatic hold to carry your drum in vertical position. The gripping action is completely mechanical and automatic. With the “head” containing the jaws below the level of the drum rim, simply press Model 82H-XR against the drum, raise the “head” to engage the grip and lift drum. Move your drum to the desired location. The jaws release when drum is set down on floor or pallet.

Jaws grip the upper rim of a plastic, steel or fiber drum weighing up to 600 Lb. (272 kg).



82H-XR SERIES

Extended Reach Drum Movers & Palletizers

SPECIFICATIONS SHEET

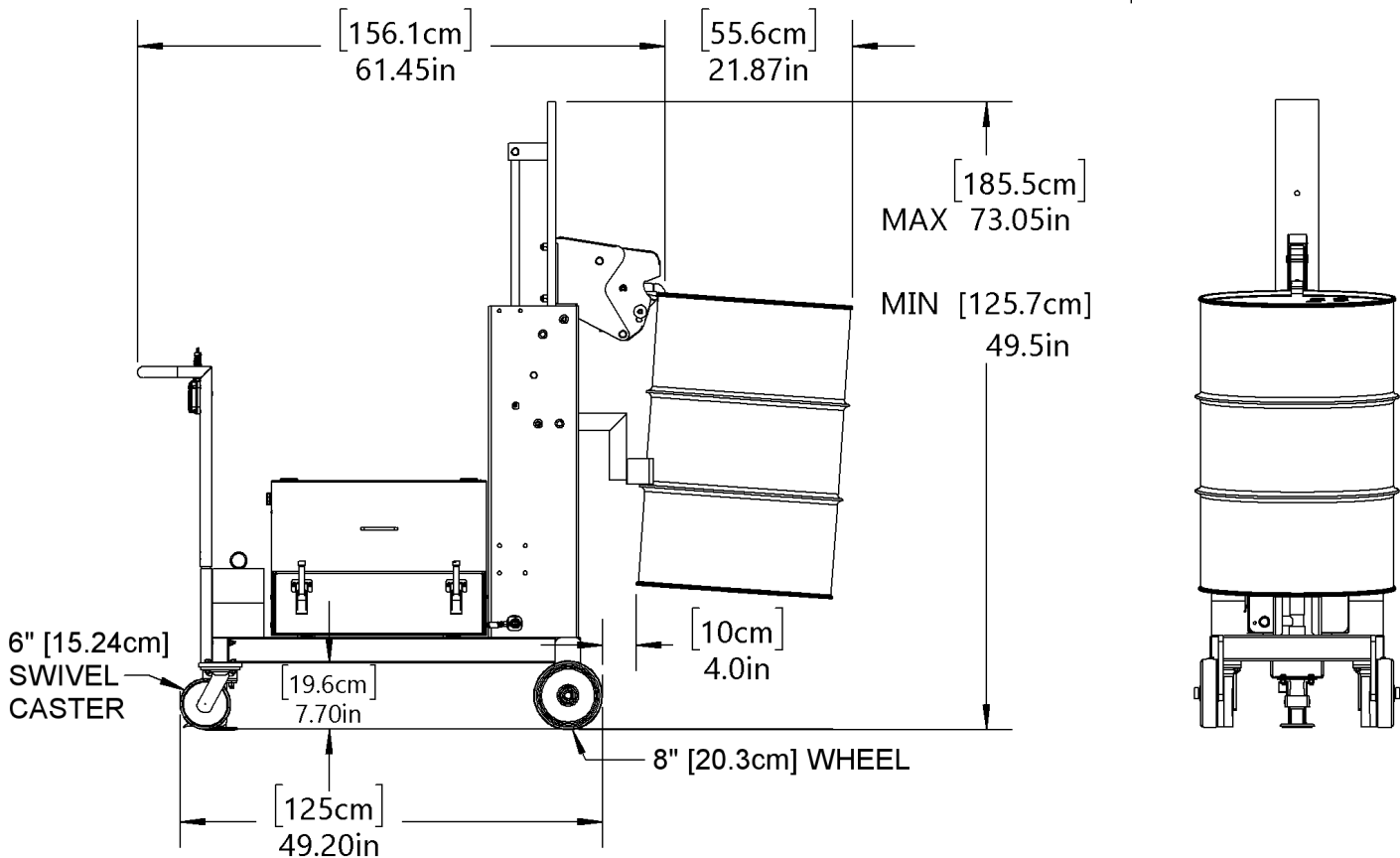
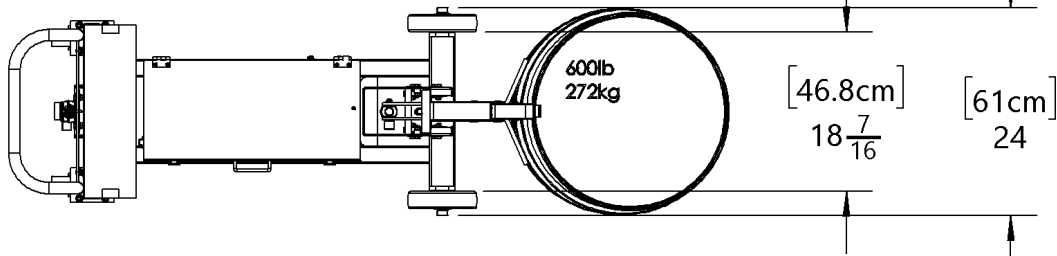
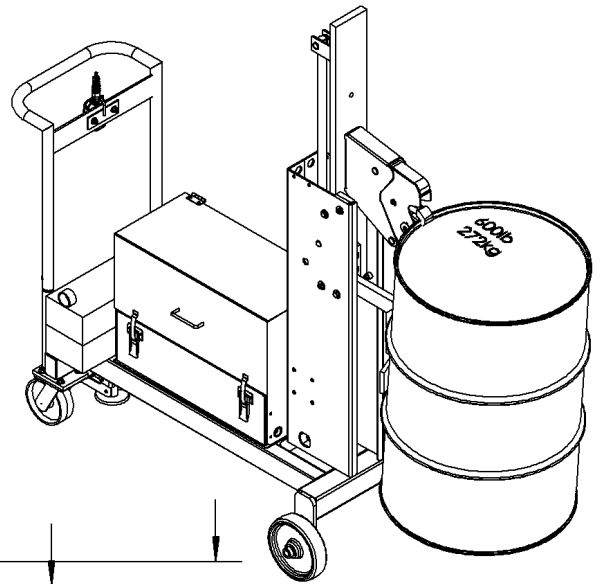



82H-XR SERIES

Extended Reach Drum Movers & Palletizers

SPECIFICATIONS SHEET

Bolt the Head to the Riser in Position **A**, **B** or **C**

