



MODEL 85-5

SPECIFICATIONS SHEET

BELOW-HOOK 5-GALLON PAIL HANDLER

Model 85-5 Below-hook Pail-Karrier allows you to use your crane or hoist to lift and control pouring of a 5-gallon (19 liter) plastic or metal pail.

- 11" to 12" (28 to 30.5 cm) in diameter
- Weighing up to 200 Lb. (91 kg)

Morse **PailPRO™** Series Pail Handlers address today's high expectations for workplace ergonomics. Innovative 5-gallon (19 liter) pail handlers increase operational efficiency and address safety concerns.

- Reduce the chance of worker's compensation claims
- Prevent repetitive motion injuries
- Increase employee safety
- Reduce error rates
- Increase product quality



Suspend model 85-5 on your hook



Lock pail upright to transport



Lock pail in horizontal position to pour



MODEL 85-5

Below-Hook Pail Carrier

SPECIFICATIONS SHEET

Steps to Use Pail-Karrier

- Secure pail:
 - Drape Web Strap around pail
 - Insert Hook into Eye
 - Operate ratchet to tighten web strap around pail
 - Adjust top bracket to pail height
- Steady pail with hand and release Tilt-Lock
- Use Hand Wheel to dispense pail. Vary pouring angle or lock in various positions with Tilt-Lock
- After pouring, rotate pail back to vertical position and lower.

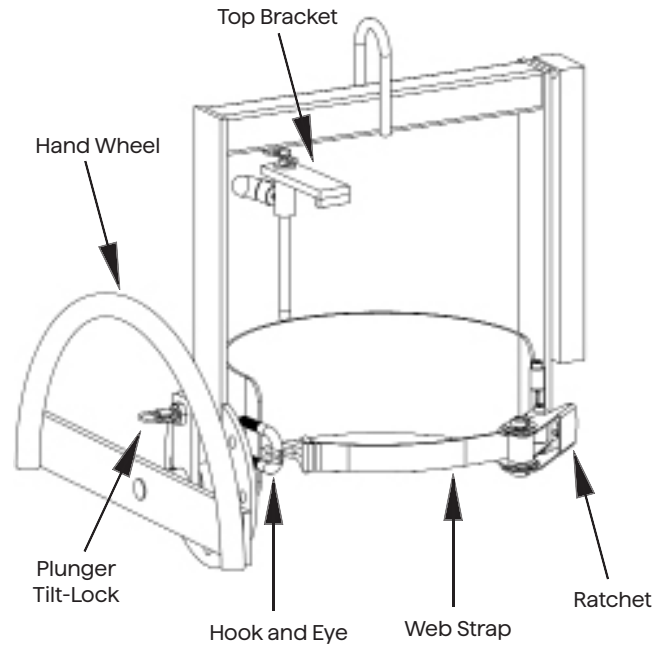

Dimensions

