

CONTENTS

- Receiving Procedures
- Warranty
- Safety Information
- Machine Description
- Installation Instructions
- Operating Instructions
- Maintenance

Receiving Procedures

Every Morse drum handler is inspected prior to shipping. However, damage may be incurred during transit.

- Check for visible damage. If you choose to accept damaged freight, always sign noting the damage on the **BILL OF LADING**.
- Document the damage and have the truck driver sign. We recommend keeping a digital camera at your receiving dock for this purpose.
- Open packages expeditiously to check the condition of the goods. There is only a 24 hour window to notify the carrier of any concealed damage.
- **IMMEDIATELY REPORT ALL DAMAGE TO THE SHIPPING COMPANY!** Then you may contact Morse for assistance with your freight claim.
- Morse Manufacturing will not be held responsible for any damaged freight that is not signed for as damaged.

Delivery to non-business addresses without a loading dock result in additional freight charges. Residential delivery fees, inside delivery fees, re-delivery charges, and lift gate services will be added by the truck line, and are non-negotiable.

Limited 2 Year Warranty

Morse drum handling equipment is guaranteed against defects in workmanship or materials for **TWO YEARS** when used properly within

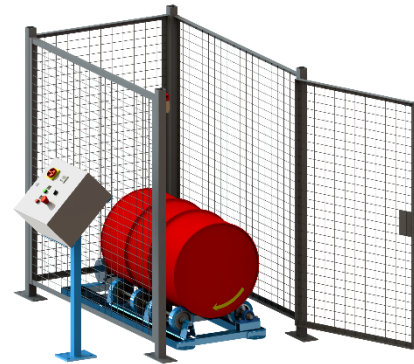

its rated capacity. Warranty does not cover wear from normal use or damage from accident or abuse. Motors and other purchased parts carry the warranties of their manufacturers.

For warranty claims, contact your Morse Dealer to obtain a return authorization number, and for return freight advice. Return freight must be prepaid.

In all instances, liability is limited to the purchase price paid or to repairing or replacing the product. Customer assumes liability for any modifications, unauthorized repairs or parts substitution.

Safety Information

While Morse Manufacturing Co. drum handling equipment is engineered for safety and efficiency, a high degree of responsibility must be placed upon the machine operator to follow safe practices, based primarily on common sense, upon which true safety depends.

Failure to follow the safety precautions in this manual can result in personal injury or property damage. Observe the same precautions as with similar machinery where carelessness in operating or maintenance is hazardous to personnel. Carefully read the safety precautions below and throughout this manual.

Review the Material Safety Data Sheet(s) for the material(s) in the drum(s) and take all necessary precautions. Safety shoes, work gloves, hard hat and other personal protective devices are recommended.

Prior to initial use, inspect all moving parts and test rotation of wheels. Perform necessary inspections, operator training, etc.













DANGER - Indicates a situation which, if not avoided, will result in serious injury or death. This signal word is limited to the most extreme situations.



WARNING - Indicates a situation which, if not avoided, could result in serious injury or death.



CAUTION - Indicates a situation which, if not avoided, can result in damage to the machine.

		<p>DANGER - Watch Out for Pinch Points. Stay clear of moving parts. Do Not Stand Near any Part of a Rotating Drum. Operator should remain directly in front of the control station while operating the Roller. Morse Drum Rollers comply with OSHA when installed in accordance with OSHA subpart O, 1910.212 - "General requirements for all machines." "Revolving drums, barrels, and containers shall be guarded by an enclosure which is interlocked with the drive mechanism, so that the barrel, drum, or container cannot revolve unless the guard enclosure is in place." A safety enclosure and interlock is included with the Morse CE marked drum roller.</p>
	<p>DANGER - Live electrical parts could cause death or shock. Lock out and tag out before working on any electrical wiring. Only qualified electricians are to do electrical work. Do not remove or install any parts while housing is connected to power.</p>	
	<p>WARNING - The 1-5154-CE Series Drum Rollers are designed to handle one drum of the types listed in Machine Description. DO NOT attempt to handle any other type of drum or object. DO NOT exceed the weight capacity.</p>	
	<p>WARNING - Level Floors Only. For operation only on clean, level floors of suitable bearing capacity. Do not use on sloped surfaces, ramps, irregular or debris strewn floors.</p>	
	<p>WARNING - Properly Mount to Floor. Do Not put into service without proper floor mounting and leveling. Use the four mounting holes in each corner of the base to anchor to floor.</p>	
	<p>WARNING - Do Not Modify the Unit. Under no circumstances should any modifications be made to the Morse machinery without factory authorization. Any modifications may void the warranty. This machine was designed to perform a specific job, and alterations may result in injury to operator or machine.</p>	
	<p>WARNING - No Loose Fitting Clothing. Wear close-fitting clothing and safety equipment appropriate to the job. Loose fitting clothing may become caught on the machinery and cause severe personal injury.</p>	
	<p>CAUTION - Wear safety shoes with non-slip soles and hard toe protection.</p>	
	<p>CAUTION - DO NOT allow drum to impact on floor, ground, etc.</p>	
	<p>WARNING - This product can expose you to chemicals including barium sulfate, cobalt, titanium dioxide, and 2-methylimidazole, which are known to the State of California to cause cancer, and bisphenol-A, which is known to the State of California to cause birth defects or other reproductive harm. For more information go to www.P65Warnings.ca.gov</p>	

Machine Description

The Morse model 1-5154-1-50-ce Drum Roller is designed to roll a steel drum, 15 cm to 71 cm (6" to 28") in diameter, up to 102 cm (40") long. The drum speed of 16 RPM was set at the factory according to customer's order specification. The drum speed is based on a 57 cm (22.5") diameter 210 liter (55-gallon) steel drum and a 50 Hz, 1425 RPM motor. The maximum liquid capacity is 454 kg (1000 lb.). Maximum dry load capacity is 136 kg (300 lb.).

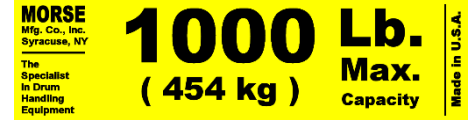

Controls

The Morse model 1-5154-1-50-ce control package includes the following features: a start & stop button along with a red emergency stop button. A lockable main disconnect to shut off and lock out power to the unit. A 24V DC control supply. Wire terminals for external connection of a safety interlock switch. A timer for controlling the duration of drum rolling time, from a few seconds to multiple hours.

Installation

Install all Morse Drum Rollers in accordance with CE requirements for enclosure and safety interlock, etc. Drum Roller must automatically turn off when enclosure door is opened.

Machine Unpacking

Carefully remove the top and sides of the crate covering the machine so as not to damage painted surfaces or electrical components. Inspect the machine for visible damage. If damage is noted, follow receiving procedure. Remove the (4) lag screws connecting the machine base to the pallet. Remove machine from pallet by lifting from roller shafts. Attach a strap to an overhead crane and raise slowly, as the machine will have a tendency to tilt.

Installation / Assembly Instructions

- The Roller base has four 1.27 cm (1/2") holes spaced 48.26 cm wide x 128.3 cm long (19" x 50.5"). Morse recommends the Roller be secured to the floor using four .95 cm diameter x 7.6 cm long (3/8" x 3") lag bolts (not included).
- Secure control mast to floor using four .95 cm diameter x 7.6 cm long (3/8" x 3") stud anchors (not included). Install mast outside of safety enclosure.
- Install enclosure and safety interlock around drum roller (see enclosure instructions). Drum roller must automatically turn off when enclosure door is opened.
- Control Station - Making Connections (see control box wiring diagram):
 - Drum Roller is shipped with motor and interlock switch wired to control box. An electrician needs to install **1PH/220V** power supply to control box. All wiring must be to national and local codes. With power to circuit locked out and tagged out, connect control panel to plant circuit.
 - Close the control panel before powering up.

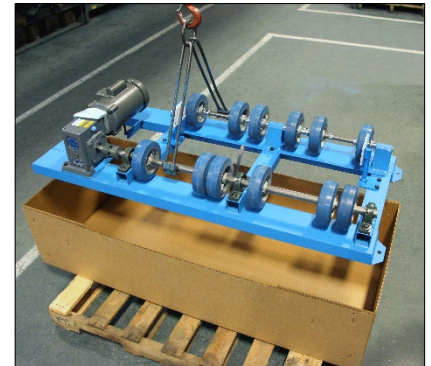
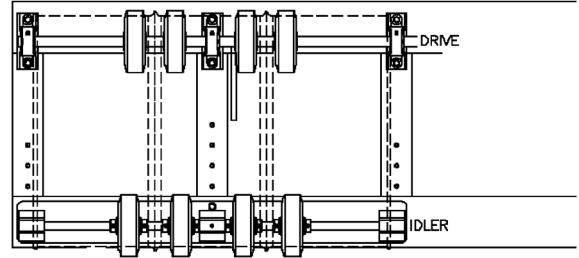
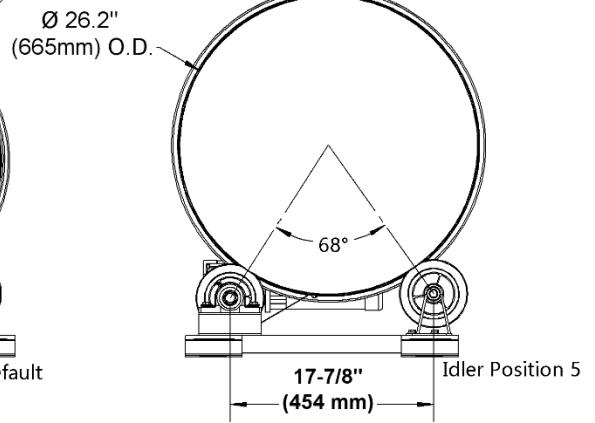
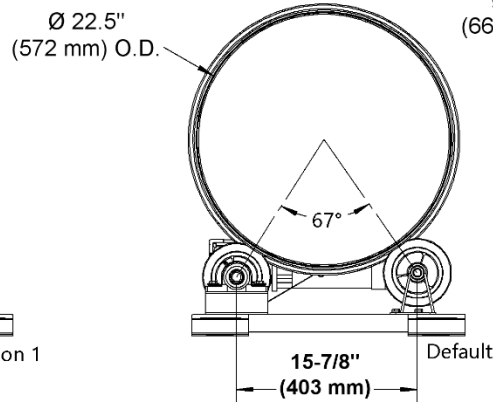
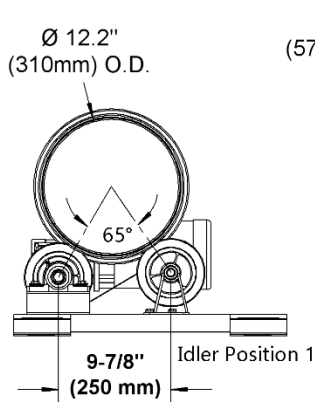
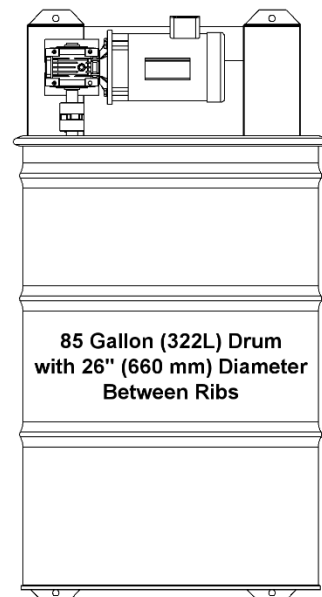
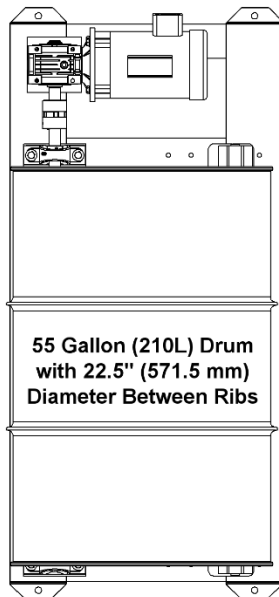
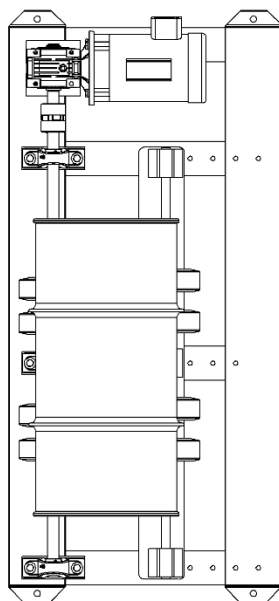

Figure 3.1

1. Adjust drive and idler wheels to your particular drum.
 - a. With provided 1/8" allen wrench, loosen two set screws found in each drive wheel hub and set screw in each collar around idler wheels.
 - b. Position wheels along shafts to support drum at strongest points on drum; adjacent to ribs. This configuration also prevents drum from moving axially.
 - c. Tighten set screws.



2. Adjust Idler Plate position to accommodate different drum diameters. Move idler plate assembly toward drive side for smaller diameters and away from drive side for larger diameters. Units ship with idler plate preset for standard 210 liter (55-gallon) steel drum. To adjust, remove three idler plate bolts and slide idler plate assembly to proper set of holes and refasten mount bolts. See example idler plate positions shown below.



Important

When loading, unloading, operating, or maintaining your MORSE drum roller, always use care and good judgment. Maintain secure footing and a firm hold. Keep hands and loose clothing away from all moving parts. Never allow anyone to be below any part of a raised drum handler or drum. Read operating instructions and review the pictures in the sales brochure before operation.

Operating Instructions

Loading a Drum

1. Drum should be loaded onto the roller horizontally.
2. Use a Drum Truck like Morse model 160 to tilt a vertical drum to horizontal. Once drum is horizontal, use chime hook to extend support prop (kickstand) for stability.
3. Overhead lifting equipment and the Morse model 41 Drum Lifting hook provide an effective system for lifting a horizontal 210 liter (55-gallon) steel drum.
4. Attach model 41 lifting ring to your hoist hook.
5. Move hoist with Drum Lifting Hook over drum and lower. Hoist should be guided so that Drum Lifting Hook settles across center of horizontal drum.
6. Place a lifting hook on each end of drum below drum rim.
7. Raise hoist to lift drum (figure 5.1). Move drum over drum roller.
8. Lower hoist to place drum onto roller wheels (figure 5.2). Continue to lower hoist so that Drum Lifting Hooks may be removed.
9. Raise hoist to lift model 41 clear of drum.



Figure 5.1



Figure 5.2

Rotating a Drum

1. Once drum has been loaded onto roller wheels, close guard enclosure to engage interlock switch.
2. Power up control panel. Press green START button.
3. Set timer to rotate drum for desired time. Use buttons to adjust seconds, minutes & hours.
4. Press black STOP button to stop rolling. A red EMERGENCY STOP button is included in case of emergency. Push to activate and twist to release.

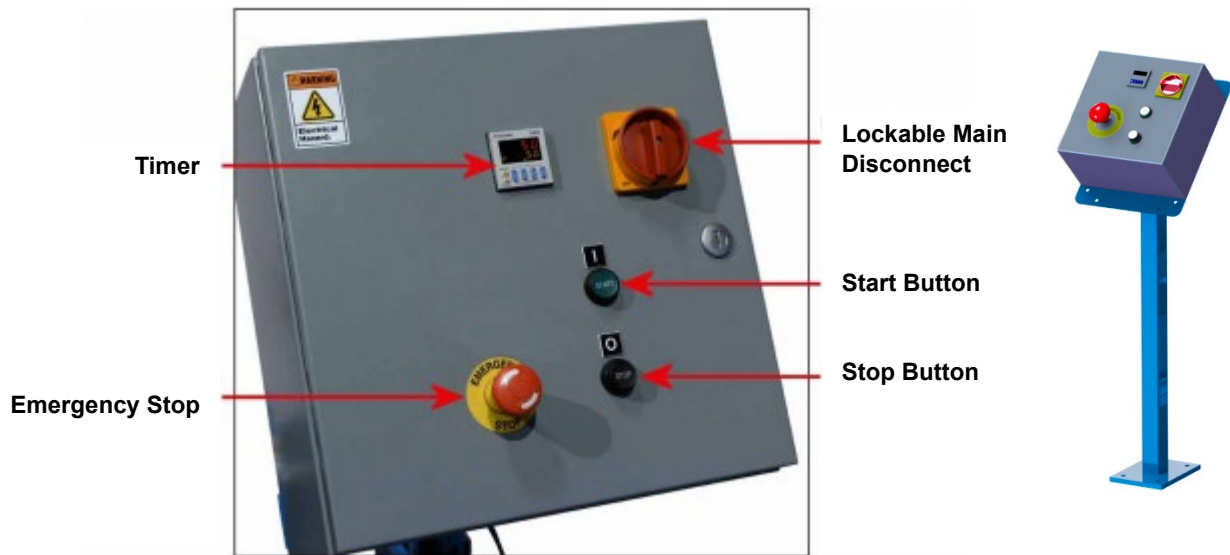

Figure 6.1

Unloading a Drum

Once drum has finished rolling, open guard enclosure.

1. Raise drum with hoist and model 41 drum lifting hook.
2. Move hoist over model 160 and lower drum onto it.
3. Disengage support prop (kickstand) by releasing chime hook, install chime hook onto top rim.
4. Slowly rock drum over from horizontal to vertical.

Preventative Maintenance

Periodic inspection for the general condition of structural and mechanical components is imperative for safe and efficient operation. Tighten, adjust or replace parts as necessary to prevent failure and maintain proper function.

Monthly

Inspect all moving parts, framework, and floor mounting fasteners for signs of wear, fatigue, or loosening.
Replace any parts that show signs of wear.

Every 6 to 12 Months in Ordinary Environment (monthly in dirty conditions)

Inspect oil level in gear box / speed reducer and fill with high quality, synthetic lubricant for gears if necessary. Use Enduratex EP 460 Synthetic oil or equivalent. The speed reducer has been filled and tested prior to shipment. After operating a new machine for 1500 hours, the housing should be thoroughly flushed out and new oil added to fill the housing to the oil level plug. The oil should be changed every 5000 operating hours thereafter or more often if operating conditions cause condensation of moisture resulting in sludge formation inside housing.

Lubricate all moving parts including: pillow block bearings and idler wheels.

- Pillow Block Bearings: Grease every 6-12 months in ordinary environment, grease monthly in dirty conditions. See [Bearing Lubrication Sheet](#) for grease types and fill amounts.
- Idler wheels are equipped with grease fitting and should be lubricated every 6-12 months in ordinary environment, grease monthly in dirty conditions. Any common bearing grease will suffice (i.e Shell Alvania).

1-5154-1-50-ce Specification Sheet	
Capacity: Liquid Load Dry load	454 kg (1000 Lb.) 136 kg (300 Lb.)
Drum sizes: Drum Diameter Drum Height	150 mm to 710 mm (6" to 28") Up to 1020 mm (40")
Drum RPM:	16
Machine Height:	304.8 mm (12")
Machine Floor Space:	1473.2 mm Long x 609.6 mm Wide (58" Long x 24" Wide)
Enclosure Height:	1606.6 mm (63.25")
Enclosure Floor Space:	1625.6 mm Long x 1016 mm Wide (64" Long x 40" Wide)
Shipping Weight:	376.5 kg (830 Lb.)
AC Motor Specs for Model 1-5154-1-50-CE .37 KW (1/2HP) 1PH 1425 RPM 50HZ 56C TEFC	VOLTS (AMP DRAW) 220V (2.5 Amps)