

Contents

	Page
Receiving Procedures.	1
Warranty.	1
Safety Information.	1 - 2
Machine Description.	2
Assembly & Operating Instructions.	3
Maintenance.	3
Parts Lists and Diagrams.	4 - 5

Operator's Manual
for Morse Extra Heavy-Duty
Kontrol-Karrier with 3-Piece Saddle
Model 185G-GR

Serial Number 0600 to 1207 (MMYY)

Receiving Procedures

- Every Morse drum handler is inspected prior to shipping. However, damage may be incurred during transit.
- Check for visible damage. If you choose to accept damaged freight, always sign noting the damage on the **BILL OF LADING**.
 - Document the damage and have the truck driver sign. We recommend keeping a digital camera at your receiving dock for this purpose.
 - Open packages expeditiously to check the condition of the goods. There is only a 24 hour window to notify the carrier of any concealed damage.
 - **IMMEDIATELY REPORT ALL DAMAGE TO THE SHIPPING COMPANY!** Then you may contact Morse for assistance with your freight claim.
 - Morse Manufacturing will not be held responsible for any damaged freight that is not signed for as damaged.

Delivery to non-business addresses without a loading dock result in additional freight charges. Residential delivery fees, inside delivery fees, re-delivery charges, and lift gate services will be added by the truck line, and are non-negotiable.

Limited 2 Year Warranty

Morse drum handling equipment is guaranteed against defects in workmanship or materials for **TWO YEARS** when used properly within its rated capacity. Warranty does not cover wear from normal use or damage from accident or abuse. Motors and other purchased parts carry the warranties of their manufacturers.

For warranty claims, contact your Morse Dealer to obtain a return authorization number, and for return freight advice. Return freight must be prepaid.

In all instances, liability is limited to the purchase price paid or to repairing or replacing the product. Customer assumes liability for any modifications, unauthorized repairs or parts substitution.

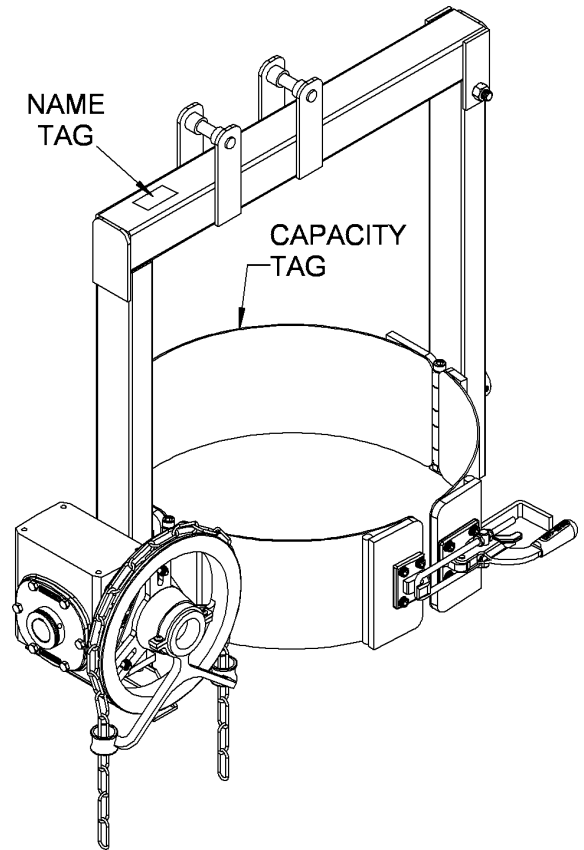

Safety Information

While Morse Manufacturing Co. drum handling equipment is engineered for safety and efficiency, a high degree of responsibility must be placed upon the machine operator to follow safe practices, based primarily on common sense, upon which true safety depends.

Failure to follow the safety precautions in this manual can result in personal injury or property damage. Observe the same precautions as with similar machinery where carelessness in operating or maintenance is hazardous to personnel. Carefully read the safety precautions throughout this manual.

Safety Information (continued)



DANGER - Indicates a situation which, if not avoided, *will* result in serious injury or death. This signal word is limited to the most extreme situations.



WARNING - Indicates a situation which, if not avoided, *could* result in serious injury or death.



CAUTION - Indicates a situation which, if not avoided, can result in damage to the machine.



WARNING - The Extra Heavy-Duty Kontrol-Karrier with 3-Piece Saddle is designed to handle one drum of the types listed under **Machine Description**. *DO NOT* attempt to handle any other type of drum or object. *DO NOT* exceed the weight capacity of 2,000 Lb.



WARNING - Do Not Modify the Unit

Under no circumstances should any modifications be made to the Morse machinery without factory authorization. Any modifications may void the warranty. This machine was designed to perform a specific job and alterations may result in injury to operator or machine.



WARNING - No Loose Fitting Clothing

Wear close-fitting clothing and safety equipment appropriate to the job. Loose fitting clothing may become caught on the machinery and cause severe personal injury.



CAUTION - Wear Safety Shoes

Wear safety shoes with non-slip soles and hard toe protection.

Important

1. Review the Material Safety Data Sheet(s) for the material(s) in the drum(s) and take all necessary precautions. Safety shoes, work gloves, hard hat and other personal protective devices are recommended.
2. Please read all instructions *thoroughly* before attempting to operate your new MORSE drum handler.
3. When loading, unloading, operating, or maintaining your MORSE drum handler, always use care and good judgment. Maintain secure footing and a firm hold. Keep hands and loose clothing away from all moving parts. Never allow anyone to be below any part of a raised drum handler or drum. Read operating instructions and review the pictures in the sales brochure before operation.

Machine Description

1. The model 185G-GR has a maximum capacity rating of 2,000 Lb. full drum and 1,000 Lb. half-full drum and is designed to lift, move and pour *a 55-gallon steel drum*. *DO NOT* exceed these ratings. Exceeding these ratings or handling drums other than those mentioned above is unsafe and could result in equipment damage, excessive wear or awkward handling.
2. The model 185G-GR is a "Group 1 - Structural and Mechanical" Below-the-Hook Lifting Device which is covered by the American National Standard ANSI/ASME B30.20. The user should comply with all aspects of this standard.

Assembly Instructions

1. Remove the assembled chain wheel (item 27) and pull chain (item 26) from the small cardboard box packaged with the 185G-GR.
2. Remove three nuts (item 24) and three washers (item 23) from triangle bolts (item 19).
3. Slide chain wheel assembly onto three bolts (item 19).
4. Place three outside washers and nuts onto triangle bolts. Tighten nuts to secure chain wheel.
5. Install speed reducer oil vent plug and check oil level as shown in the speed reducer owners manual.
6. Prior to initial use, inspect all moving parts and test rotation of chain wheel and saddle assembly. Perform necessary load test, inspections, operator training, etc. as prescribed in the ANSI/ASME B30.20 standard.

Operating Instructions

1. With Kontrol-Karrier standing on the floor, lower hoist and engage hoist hook into the lifting eye closest to the chain wheel.
2. Raise hoist to lift Kontrol-Karrier clear of floor and move it to the drum. (Kontrol-Karrier should hang plumb.)
3. Position Kontrol-Karrier at a height which aligns the saddle band with the center of the drum.
4. Open the toggle clamp by activating the release lever (item 12) and swing both hinge bands to the open position. Push the Kontrol-Karrier against the drum to surround the drum with the saddle band.
5. Close the two hinged bands around the drum and latch the toggle clamp to secure the drum.
6. Lower hoist hook until slack. Relocate hoist hook to lifting eye that is centered over drum.
7. Raise hoist and position the drum at the pouring station.
8. Pour the drum by pulling on the pull chain (item 26) and rotating the drum to a suitable pouring angle.
9. After pouring is completed, rotate the drum back to vertical position and lower hoist to return drum to floor. Relocate hoist hook to lifting eye closest to the chain wheel.
10. Remove the drum by activating the release lever and opening the toggle clamp. Swing both hinged bands open. Push the Kontrol-Karrier away from the drum.



CAUTION - DO NOT allow drum to impact on floor, ground, or dumping station, etc.



CAUTION - DO NOT exceed weight capacity of 2,000 Lb. for FULL drum, 1,000 Lb. for HALF-FULL drum.

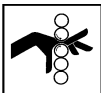

WARNING - Watch Out for Pinch Points - Stay clear of moving parts.

Maintenance

1. Inspect oil level in speed reducer.
2. Periodically inspect all moving parts, framework, and contact areas for signs of wear, fatigue, or loosening. Perform all inspections, load tests, and maintenance according to the ANSI/ASME B30.20 standard.
3. Ensure all labels are in place. Product labels should be inspected periodically and cleaned as necessary to maintain good legibility. Please contact Morse Mfg. Co. for replacement labels.



Parts List

**for Morse Extra Heavy-Duty Kontrol-Karrier with 3-Piece Saddle Model 185G-GR
Serial Number 0600 to 1207 (MMYY)**

ITEM #	QTY	PART #	DESCRIPTION
1	1	1463-P	OVERHEAD WELD W/BRG, 185GR
2	1	565-P	HHCS, 5/8-11 X 4-1/2 GR5
3	1	1473-P	NUT, LOCK, 5/8-11 REV HEX
4	1	550-P	IDLER ARM W/ BRG, 185GR
5	1	570-P	COLLAR, 1-1/2" ID
6	2	560-P	BEARING, 1-1/2" ID X 2", GR
7	1	2474CPT-P	SADDLE ASM, G-GR, 195G, 3PC
8	2	3592-P	SHCS, 1/2-13 X 7-1/2
9	2	540-P	WASHER, 1-1/2 SAE FL 3" OD
10 *	1	3387CPT-P	FRONT BAND CPT, CLAMP, 3PC GR
11 **	1	4187-P	TOGGLE CLAMP, W/ U BOLT
12	1	3601-P	RELEASE LEVER, 2984-P
13	1	4190-P	U-BOLT, 375-R CLAMP, 7"
14	8	22-P	SHCS, 3/8-24 X 5/8
15	1	3067-P	CATCH, 375-R TOGGLE, CAMLOCK
16 ***	1	3386CPT-P	FRONT BAND CPT, CATCH, 3PC GR
17	2	810-P	NUT, LOCK, 1/2-13 REV HEX
18	1	525-P	KEY, WOODRUFF, SIZE F, ASA1211
19	5	535-P	HHCS, 3/8-16 X 1-1/4 GR5
20	2	1474-P	WASHER, 3/8 SPLIT LOCK
21	1	514-P	SPEED REDUCER, 185GR, 195A
22	1	3191-P	KEY, SQUARE, 3/16 X 3/4"
23	9	1166-P	WASHER, 3/8 USS 1" OD
24	3	1169-P	NUT, LOCK, 3/8-16 REV HEX
25	1	2138-P	COLLAR, SINGLE SPLIT, 3/4"
26	1	2329-P	PULL CHAIN, 4/0 LOCK LINK, 13'
27	1	500-P	CHAIN WHEEL W/ GUIDE 4/0 185GR
28	1	3222-P	TRIANGLE WELD, 185GR

* Item 10 includes items 11 and 14

** Item 11 includes items 12 and 13

*** Item 16 includes items 14 and 15

Parts Diagram

**for Morse Extra Heavy-Duty Kontrol-Karrier with 3-Piece Saddle Model 185G-GR
 Serial Number 0600 to 1207 (MMYY)**

