

**CONTENTS**

	Page
Receiving Procedures. . . . .	1
Warranty. . . . .	1
Safety Information. . . . .	1 - 2
Machine Description. . . . .	3
Operating Instructions. . . . .	3
Maintenance. . . . .	3
Model Specs. . . . .	4
Parts List and Diagram. . . . .	5

**Operator’s Manual  
for Morse Can Tumblers  
305 Series  
Serial Number 174638 to 289776**



**Receiving Procedures**

Every Morse drum handler is inspected prior to shipping. However, damage may be incurred during transit.

- Check for visible damage. If you choose to accept damaged freight, always sign noting the damage on the **Bill of Lading**.
- Document the damage and have the truck driver sign. We recommend keeping a digital camera at your receiving dock for this purpose.
- Open packages expeditiously to check the condition of the goods. There is only a 24 hour window to notify the carrier of any concealed damage.
- Immediately **report all damage to the shipping company!** Then you may contact Morse for assistance with your freight claim.
- Morse Manufacturing will not be held responsible for any damaged freight that is not signed for as damaged.

**Limited 2 Year Warranty**

Morse drum handling equipment is guaranteed against defects in workmanship or materials for two years when used properly within its rated capacity. Warranty does not cover wear from normal use or damage from accident or abuse. Motors and other purchased parts carry the warranties of their manufacturers.

For warranty claims, contact your Morse Dealer to obtain a return authorization number, and for return freight advice. Return freight must be prepaid.

In all instances, liability is limited to the purchase price paid or to repairing or replacing the product. Customer assumes liability for any modifications, unauthorized repairs or parts substitution.

**Safety Information**

While Morse Manufacturing Co. drum handling equipment is engineered for safety and efficiency, a high degree of responsibility must be placed upon the machine operator to follow safe practices, based primarily on common sense, upon which true safety depends.

Failure to follow the safety precautions in this manual can result in personal injury or property damage. Observe the same precautions as with similar machinery where carelessness in operating or maintenance is hazardous to personnel. Carefully read the safety precautions below and throughout this manual.

Review the Material Safety Data Sheet(s) for the material(s) in the drum(s) and take all necessary precautions. Safety shoes, work gloves, hard hat and other personal protective devices are recommended.

Prior to initial use, inspect all moving parts and test rotation of chain wheel and saddle assembly. Inspect saddle assembly for proper operation. Perform necessary load test, inspections, operator training, etc.

**Operator's Manual for Morse Can Tumblers 305 Series  
Serial Number 174638 to 289776**

**Safety Information** (continued)



**DANGER** - Indicates a situation which, if not avoided, will result in serious injury or death. This signal word is limited to the most extreme situations.



**WARNING** - Indicates a situation which, if not avoided, could result in serious injury or death.



**CAUTION** - Indicates a situation which, if not avoided, can result in damage to the machine.



**WARNING** - The Can Tumbler is designed to handle one can or pail of the types listed at the top of page 3 Machine Description. DO NOT attempt to handle any other type of can or object. DO NOT exceed the weight capacity of 100 Lb. per can.



**WARNING** - Do Not Modify the Unit. Under no circumstances should any modifications be made to the Morse machinery without factory authorization. Any modifications may void the warranty. This machine was designed to perform a specific job and alterations may result in injury to operator or machine.



**WARNING** - No Loose Fitting Clothing. Wear close-fitting clothing and safety equipment appropriate to the job. Loose fitting clothing may become caught on the machinery and cause severe personal injury.



**CAUTION** - Wear safety shoes with non-slip soles and hard toe protection.



**CAUTION:** DO NOT allow can to impact on floor, ground, or dumping station, etc.



**WARNING:** This product can expose you to chemicals including cobalt, titanium dioxide, and 2-methylimidazole, which are known to the State of California to cause cancer, and bisphenol-A, which is known to the State of California to cause birth defects or other reproductive harm. For more information go to [www.P65Warnings.ca.gov](http://www.P65Warnings.ca.gov)

**Important**

1. Review the Material Safety Data Sheet(s) for the material(s) in the drum(s) and take all necessary precautions. Safety shoes, work gloves, hard hat and other personal protective devices are recommended.
2. Please read all instructions thoroughly before attempting to operate your new Morse drum handler.
3. Morse Can Tumblers have a 100 Lb. per can capacity. Do NOT exceed this rating. Exceeding this rating or handling cans other than those mentioned above is unsafe and could result in equipment damage, excessive wear or awkward handling.
4. When loading, unloading, operating, or maintaining your MORSE Can Tumbler, always use care and good judgment. Maintain secure footing and a firm hold. Keep hands and loose clothing away from all moving parts. Never allow anyone to be below any part of a raised drum handler or drum. Read operating instructions and review the pictures in the sales brochure before operation.
5. Prior to initial use, inspect all moving parts and test rotation of can holder assembly for proper operation. Perform necessary load test, inspections, operator training, etc.

**Operator's Manual for Morse Can Tumblers 305 Series  
Serial Number 174638 to 289776**

**Machine Description**

Morse Can Tumblers have a maximum capacity rating of 100 Lb. (45.5 kg) per can holder and is designed to rotate a can at an angle resulting in a "corner over corner" mixing action. The can holder will accept cans 4.5" to 16.5" (12 to 42 cm) tall, and up to 12.5" (31 cm) diameter. DO NOT exceed these ratings. Exceeding these ratings or handling cans other than those mentioned above is unsafe and could result in equipment damage, excessive wear or awkward handling. Tumbling speed is 23 RPM (19 RPM on 50Hz models).

**Assembly Instructions**

1. Remove the following items from the cardboard box: 305 base and can holder complete.
2. Slide can holder complete (item 31) onto drive shaft (item 28) and attach with provided roll pin (item 11).

**Installation Instructions**

1. The 305 base should be bolted to the floor using the 4 holes provided in the base frame.
2. The base has four holes spaced 26" (66 cm) wide x 26-5/8" (67.6 cm) long. Morse recommends the rotators be secured to the floor using 3/8" (.95 cm) x 3" (7.62 cm) lag bolts. Customer is responsible for choosing proper size and type to best suit their needs.
3. Install all Morse Rotators in accordance with OSHA requirements for enclosure and safety interlock, etc. so the rotator automatically turns off when enclosure door is opened. One way to accomplish this is with a Morse enclosure with safety interlock. For OSHA compliance, see OSHA subpart O.1910.212(a) (4) "Barrels, containers, and drums. Revolving drums, barrels, and containers shall be guarded by an enclosure which is interlocked with the drive mechanism, so that the barrel, drum, or container cannot revolve unless the guard enclosure is in place."
4. Power connections and motor controls must comply with applicable codes.

**Guard Enclosure Kit Sold Separately**

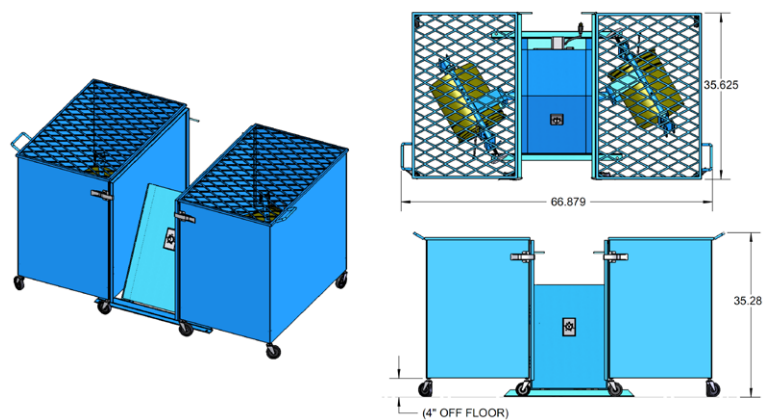

**Operating Instructions**

1. Place can in can holder (item 31) so that the weight is centered in the can holder. This can be done by adjusting the bottom cross bar using the holes and 2 adjusting pins provided (item 32).
2. Clamp down on can with top cross bar by turning handwheel (item 17) until bar secures the can. Turn screw lock (item 13) down until its tight against the 5/8-8 acme nut mounted on the top channel. The can is now secure for rotating.
3. The 305 with the single phase tefc motor comes with a cord, plug and timer. The timer allows operator to select running time up to 60 minutes with automatic shut-off. This model can be plugged into the wall power supply and started with the timer. When starting the unit be careful to stand clear of the can holder as it will begin to rotate.
4. The 305 with the three phase tefc motor and explosion proof motor (1ph or 3ph) does not come with a cord or starter. The customer is responsible for wiring up these motors in accordance with the electrical codes in their state.
5. The 305 with the air motor comes with 3/8" push lock hose and a 1/4" fitting. The customer should connect their air supply to the unit according to the air motor manufacturer's instructions. MORSE recommends 40 psi of air pressure to run unit properly.

 **CAUTION: DO NOT stand near can holder when starting unit or when unit is in operation.**

 **CAUTION: DO NOT exceed weight capacity of 100 Lb. per can.**

**Maintenance**

1. Pillow block bearings are equipped with grease fitting and should be lubricated periodically. High pressure grease guns are not recommended, as their force may damage seals.
2. Grease roller chain periodically with any sufficient grade of anti-sling grease (e.g. Whitmore lubes "surtac 2000").
3. Motors have permanently lubricated ball bearings.
4. Periodically inspect all moving parts, framework, and contact areas for signs of wear or loosening. Tighten, adjust, or replace parts as necessary to prevent failure and maintain proper function.



The Specialist In Drum Handling Equipment

## 305 Series Can Tumblers

### Operator's Manual for Morse Can Tumblers 305 Series Serial Number 174638 to 289776

Model #	Rotates	Motor HP	Motor Type	Volts	Hz	Phase	Full Load Amp Draw	Unit Weight	Ship Weight
2-305-1	1 or 2 Cans at 23 RPM	1/4 HP	TEFC with 1 to 60 minute timer	115V	60	1	5	156 Lb. (70.9 kg)	205 Lb. (93 kg)
2-305-1-50	1 or 2 Cans at 19 RPM	1/4 HP	TEFC with 1 to 60 minute timer	110 / 220V	50	1	7.2 / 3.6	168 Lb. (76.4 kg)	205 Lb. (93 kg)
2-305-1-230	1 or 2 Cans at 23 RPM	1/4 HP	TEFC	230V	60	1	2.5	156 Lb. (70.9 kg)	205 Lb. (93 kg)
2-305-3	1 or 2 Cans at 23 RPM	1/4 HP	TEFC	208-230 / 460V	60	3	1.7 / 1.3 / .65	154 Lb. (70 kg)	205 Lb. (93 kg)
2-305-3-50	1 or 2 Cans at 19 RPM	1/4 HP	TEFC	220 / 380 / 440V	50	3	1.7 / 1 / .85	153 Lb. (69.5 kg)	205 Lb. (93 kg)
2-305-575	1 or 2 Cans at 23 RPM	1/2 HP	TEFC	575V	60	3	.8	158 Lb. (71.8 kg)	205 Lb. (93 kg)
2-305-A	1 or 2 Cans at 23 RPM	1/4 HP	Air Motor	-	-	-	-	145 Lb. (65.9 kg)	190 Lb. (86 kg)
2-305-E1	1 or 2 Cans at 23 RPM	1/4 HP	Explosion Proof	115 / 208-230V	60	1	5 / 2.6-2.5	163 Lb. (74.1 kg)	210 Lb. (95 kg)
2-305-E1-50	1 or 2 Cans at 19 RPM	1/3 HP	Explosion Proof	110 / 220V	50	1	5.2 / 2.6	171 Lb. (77.2 kg)	210 Lb. (95 kg)
2-305-E3	1 or 2 Cans at 23 RPM	1/4 HP	Explosion Proof	208-230 / 460V	60	3	1.4-1.3 / .65	162 Lb. (73.6 kg)	231 Lb. (105 kg)
2-305-E3-50	1 or 2 Cans at 19 RPM	1/2 HP	Explosion Proof	220 / 380 / 440V	50	3	2 / 1.2 / 1	173 Lb. (78.6 kg)	231 Lb. (105 kg)
2-305-E575	1 or 2 Cans at 23 RPM	1/2 HP	Explosion Proof	575V	60	3	.9	173 Lb. (78.6 kg)	231 Lb. (105 kg)
1-305-1	1 Can at 23 RPM	1/4 HP	TEFC with 1 to 60 minute timer	115V	60	1	5	129 Lb. (58.6 kg)	175 Lb. (80 kg)
1-305-1-50	1 Can at 19 RPM	1/4 HP	TEFC with 1 to 60 minute timer	110 / 220V	50	1	7.2 / 3.6	141 Lb. (64.1 kg)	175 Lb. (80 kg)
1-305-1-230	1 Can at 23 RPM	1/4 HP	TEFC	230V	60	1	2.5	129 Lb. (58.6 kg)	175 Lb. (80 kg)
1-305-3	1 Can at 23 RPM	1/4 HP	TEFC	208 / 230 / 460V	60	3	1.7 / 1.3 / .65	127 Lb. (57.7 Kg)	155 Lb. (70 kg)
1-305-3-50	1 Can at 19 RPM	1/4 HP	TEFC	220 / 380 / 440V	50	3	1.7 / 1 / .85	126 Lb. (57.3 kg)	155 Lb. (70 kg)
1-305-575	1 Can at 23 RPM	1/2 HP	TEFC	575V	60	3	.8	131 Lb. (59.5 kg)	155 Lb. (70 kg)
1-305-A	1 Can at 23 RPM	1/4 HP	Air Motor	-	-	-	-	118 Lb. (53.6 kg)	155 Lb. (70 kg)
1-305-E1	1 Can at 23 RPM	1/4 HP	Explosion Proof	115 / 208-230V	60	1	5 / 2.6-2.5	136 Lb. (61.8 kg)	180 Lb. (82 kg)
1-305-E1-50	1 Can at 19 RPM	1/3 HP	Explosion Proof	110 / 220V	50	1	5.2 / 2.6	144 Lb. (65.5 kg)	180 Lb. (82 kg)
1-305-E3	1 Can at 23 RPM	1/4 HP	Explosion Proof	208-230 / 460V	60	3	1.4-1.3 / .65	135 Lb. (61.4 kg)	180 Lb. (82 kg)
1-305-E3-50	1 Can at 19 RPM	1/2 HP	Explosion Proof	220 / 380 / 440V	50	3	2 / 1.2 / 1	146 Lb. (66.4 kg)	180 Lb. (82 kg)
1-305-E575	1 Can at 23 RPM	1/2 HP	Explosion Proof	575V	60	3	.9	146 Lb. (66.4 kg)	180 Lb. (82 kg)

\* Explosion Proof Motors are rated for Class I Group D, and Class II Groups F and G.

### Operator's Manual for Morse Can Tumblers 305 Series Serial Number 174638 to 289776

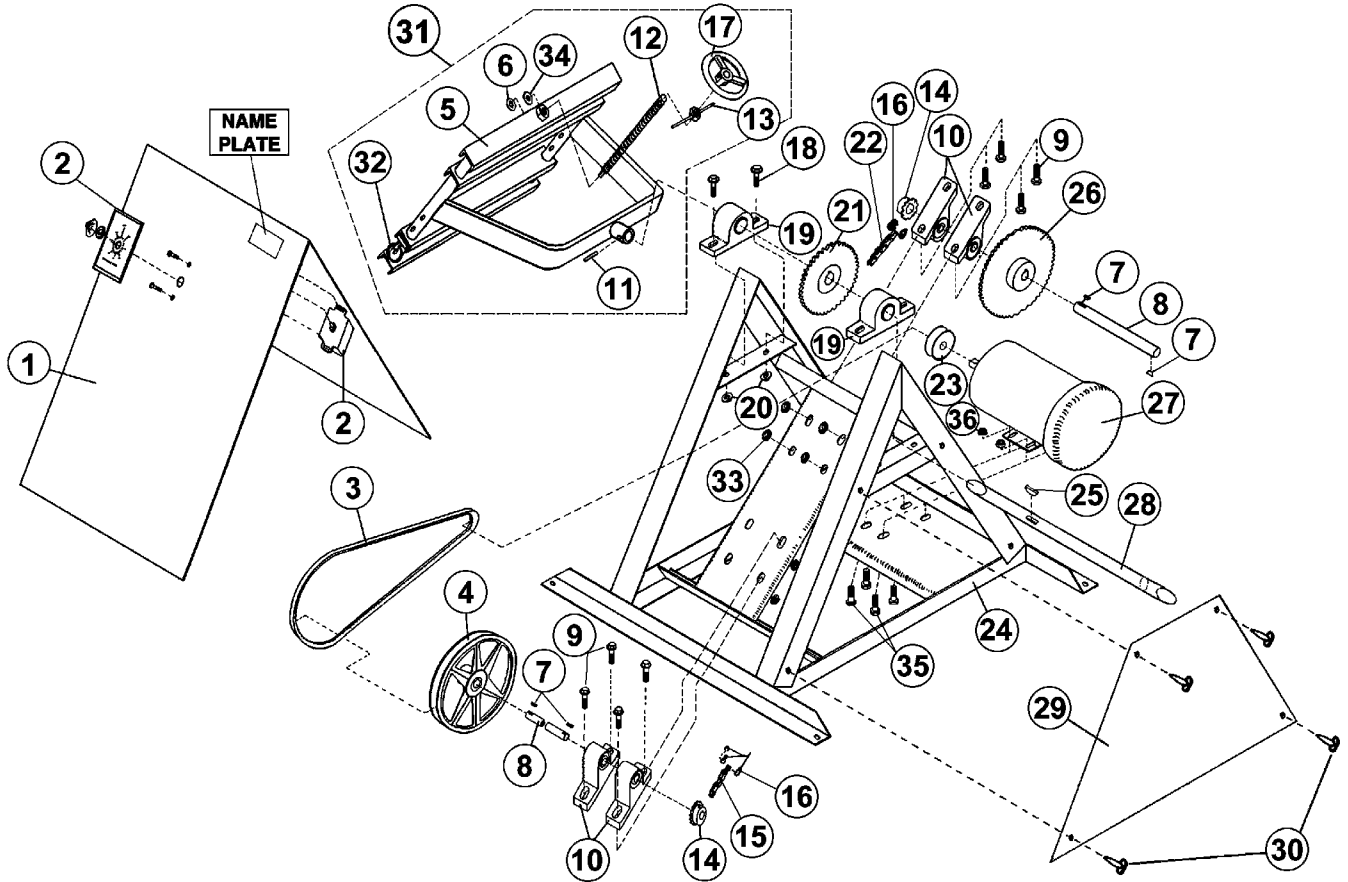

ITEM	MODEL SUFFIX	QTY.	PART #	DESCRIPTION
1		1	835-P	COVER, TOP 305 SERIES
2	-1	1	840-P	TIMER, 0-60 MIN., 305 SERIES
3*		1	845-P	VEE BELT, L SECTION, 305
4*		1	850-P	SHEAVE, 8" X 5/8 BORE, 305
5		1**	855-P	CAN HOLDER WELD, 305
6		1**	716-P	NUT, PUSH, 3/8"
7*		4	735-P	KEY, WOODRUFF, SIZE 9, ASA606
8*		2	194-P	JACK SHAFT, 201, 305 SERIES
9		8	1635-P	BOLT, 5/16-18 X 1-1/4 WHIZ
10*		4	5583-P	BEARING, 5/8" PILLOW BLOCK
11		1**	2434-P	ROLL PIN, 1/4 X 2"
12*		1**	905-P	CLAMP SCREW, 5/8 ACME, 305
13		1**	930-P	SCREW LOCK WELD, 305
14*		2	2544-P	SPROCKET #35 12T, 5/8" BORE
15*		1	942-P	CHAIN, ROLLER, #35 78 PITC
16*		2	795-P	LINK, MASTER, #35 CHAIN
17		1**	935-P	HANDWHEEL, 4" 305
18		4	4003-P	BOLT, 3/8-16 X 1-1/4 WHIZ
19*		2	297-P	BEARING, 1" PILLOW BLOCK
20		4	4002-P	NUT, 3/8-16 WHIZ LOCK
21*		1	940-P	SPROCKET #35 48T, 1" BORE
22*		1	945-P	CHAIN, ROLLER, #35 73 PITCH
23*		1	950-P	SHEAVE, 2-1/4 X 1/2 BORE, 305

ITEM	MODEL SUFFIX	QTY.	PART #	DESCRIPTION
24		1	955-P	FRAME WELD, 305 SERIES
25*		1	736-P	KEY, WOODRUFF, SIZE 15, ASA808
26*		1	2549-P	SPROCKET #35 60T, 5/8" BORE
27	-1	1	960-1-P	MOTOR, 1/4 HP, 1PH, 48, RB
27	-3	1	960-3-P	MOTOR, 1/4 HP, 3PH, 48, RB
27	-E1	1	960-E1-P	MOTOR, 1/4 HP, EXP 1PH, 48 RB
27	-E3	1	960-E3-P	MOTOR, 1/4 HP, EXP 3PH, 48 RB
27	-1-50	1	960-1-50-P	MOTOR, 1/2HP, 1PH, 48 RB 50HZ
27	-3-50	1	960-3-50-P	MOTOR, 1/4HP, 3PH RB TEFC 50HZ
27	E1-50	1	228-E1-50-P	MOTOR, 1/3HP, 1PH, RB 50HZ EXP
27	E3-50	1	228-E3-50-P	MOTOR, 1/2HP, 3PH, RB 50HZ EXP
27	-A	1	228-A-P	MOTOR, AIR, RB, 201, 305
28*		1	970-P	DRIVE SHAFT, 305 SERIES
29		2	1892-P	COVER, SIDE 305 SERIES
30		16	193-P	SCREW, 12-14 X 3/4 3 PT TEK
31		1**	855CPT-P	CAN HOLDER, CPT, 305 TYPE
32		2**	1903-P	PIN, QUICK 5/16 X 1.3, 305
33		12	1634-P	NUT, 5/16-18 WHIZ LOCK
34		1	1166-P	WASHER, 3/8 USS
35		4	35-P	HHCS, 5/16-18 X 1 GR2
36		4	1570-P	WASHER, 5/16 USS 7/8 OD

\* Recommended spare parts  
\*\* Quantity doubled for 2-305 Series