

**Dimensions of Morse Kit # 3930-P Counterweight Kit
for Model 83 PailPRO™ 5-Gallon Pail Handler
with Serial Number 0204 to ____ (MMYY)**

 **IMPORTANT
NOTE**

4-Digit serial numbers
are simply the month
& year of manufacture

Example: 0802 is
August 2002

Install counterweight with base Assembly reversed as shown below to allow reach beyond wheels.



WARNING - Use of counterweight option reduces the capacity of the model 83 PailPRO™ Pail Handler to 75 Lb. maximum per pail.

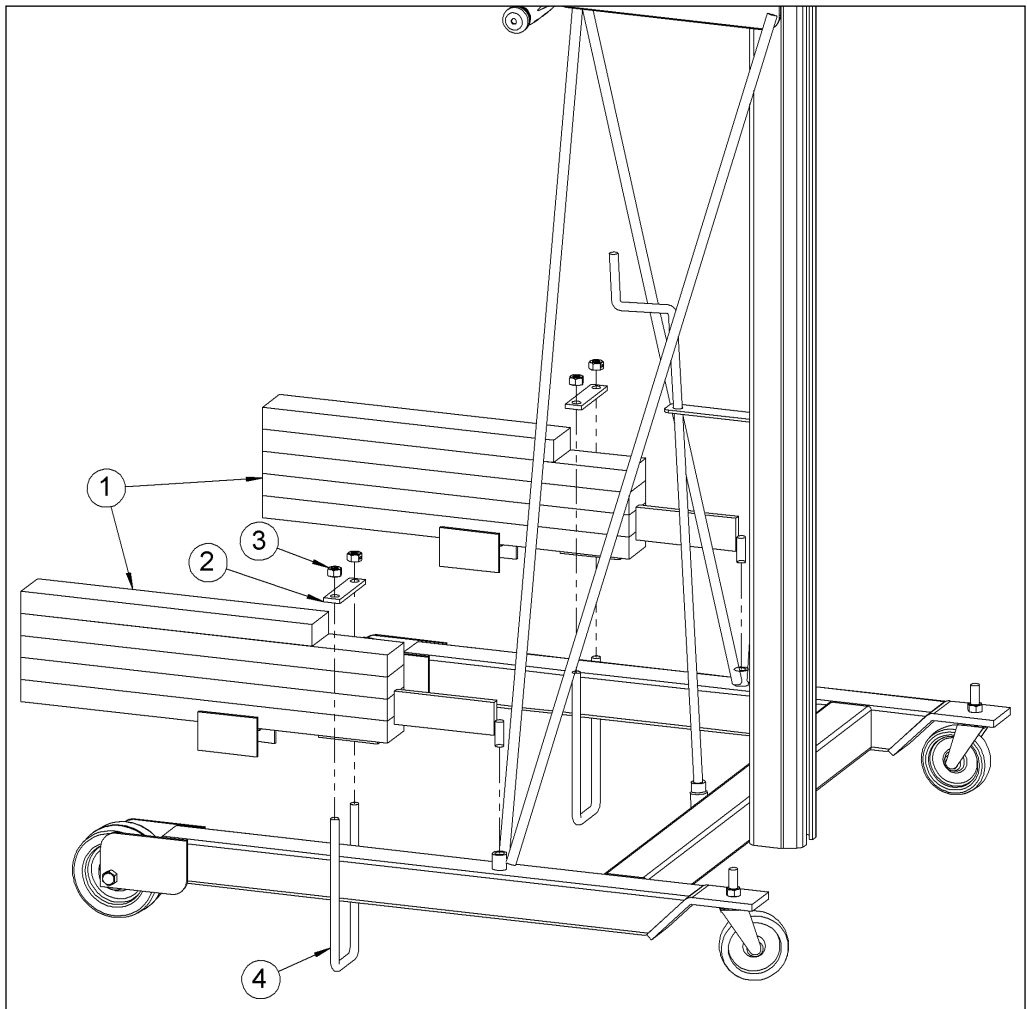

| ITEM | QTY. | PART # | DESCRIPTION |
|------|------|--------|------------------------------|
| 1 | 2 | 4443-P | COUNTERWEIGHT WELD, 83 CW |
| 2 | 2 | 3966-P | STRAP, U-BOLT MOUNT, 83 |
| 3 | 4 | 1169-P | NUT, 3/8-16 REV HEX LOCK |
| 4 | 2 | 3931-P | U-BOLT, COUNTERWEIGHT, 83 CW |

Dimensions of Morse Kit # 3930-P Counterweight Kit
for Model 83 **PailPRO™** 5-Gallon Pail Handler
with Serial Number 0204 to ____ (MMYY)

