

CONTENTS

	Page
Receiving Procedures.	1
Warranty.	1
Safety Information.	1 - 2
Machine Description.	2
Option.	2
Maintenance.	2
Assembly Instructions.	3
Parts Lists and Diagrams.	4

**Operator's Manual
 for Morse Drum Cradle Truck
 Models 40 and 40-30**

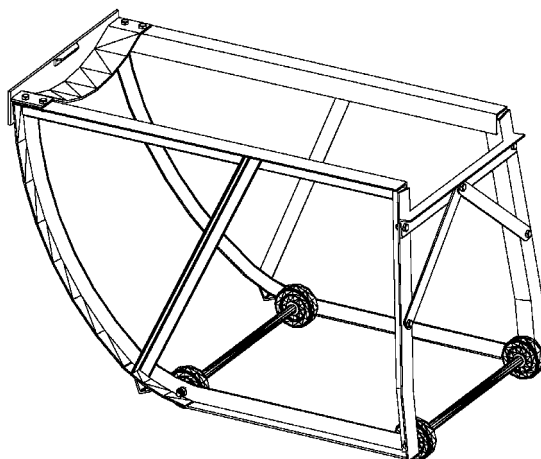

Receiving Procedures

Every Morse drum handler is inspected prior to shipping. However, damage may be incurred during transit.

- Check for visible damage. If you choose to accept damaged freight, always sign noting the damage on the **Bill of Lading**.
- Document the damage and have the truck driver sign. We recommend keeping a digital camera at your receiving dock for this purpose.
- Open packages expeditiously to check the condition of the goods. There is only a 24 hour window to notify the carrier of any concealed damage.
- Immediately **report all damage to the shipping company!** Then you may contact Morse for assistance with your freight claim.
- Morse Manufacturing will not be held responsible for any damaged freight that is not signed for as damaged.

Limited 2 Year Warranty

Morse drum handling equipment is guaranteed against defects in workmanship or materials for two years when used properly within its rated capacity. Warranty does not cover wear from normal use or damage from accident or abuse. Motors and other purchased parts carry the warranties of their manufacturers.

For warranty claims, contact your Morse Dealer to obtain a return authorization number, and for return freight advice. Return freight must be prepaid.

In all instances, liability is limited to the purchase price paid or to repairing or replacing the product. Customer assumes liability for any modifications, unauthorized repairs or parts substitution.

Safety Information

While Morse Manufacturing Co. drum handling equipment is engineered for safety and efficiency, a high degree of responsibility must be placed upon the machine operator to follow safe practices, based primarily on common sense, upon which true safety depends.

Failure to follow the safety precautions in this manual can result in personal injury or property damage. Observe the same precautions as with similar machinery where carelessness in operating or maintenance is hazardous to personnel. Carefully read the safety precautions below and throughout this manual.

Review the Material Safety Data Sheet(s) for the material(s) in the drum(s) and take all necessary precautions. Safety shoes, work gloves, hard hat and other personal protective devices are recommended.

Prior to initial use, inspect all moving parts. Perform necessary load test, inspections, operator training, etc.



morsedrum.com



service@morsedrum.com





(315) 437-8475



727 West Manlius St.
 East Syracuse, NY, 13057 USA

Operator's Manual for Morse Drum Cradle Truck Models 40 and 40-30

Safety Information (continued)

	DANGER - Indicates a situation which, if not avoided, will result in serious injury or death. This signal word is limited to the most extreme situations.
	WARNING - Indicates a situation which, if not avoided, could result in serious injury or death.
	CAUTION - Indicates a situation which, if not avoided, can result in damage to the machine.



WARNING - The Drum Cradle Truck is designed to handle one drum of the types listed below under Machine Description. DO NOT attempt to handle any other type of drum or object. DO NOT exceed the weight capacity of 700 Lb. (318 kg).



WARNING - Do Not Modify the Unit. Under no circumstances should any modifications be made to the Morse machinery without factory authorization. Any modifications may void the warranty. This machine was designed to perform a specific job and alterations may result in injury to operator or machine.



WARNING - No Loose Fitting Clothing. Wear close-fitting clothing and safety equipment appropriate to the job. Loose fitting clothing may become caught on the machinery and cause severe personal injury.



CAUTION - Wear safety shoes with non-slip soles and hard toe protection.



CAUTION: DO NOT allow drum to impact on floor, ground, or dumping station, etc.



WARNING: This product can expose you to chemicals including cobalt, titanium dioxide, and 2-methylimidazole, which are known to the State of California to cause cancer, and bisphenol-A, which is known to the State of California to cause birth defects or other reproductive harm. For more information go to www.P65Warnings.ca.gov

Machine Description

The model 40 is designed to tilt an upright 55-gallon steel drum to horizontal for dispensing. The top rim of a 55-gallon (210 liter) steel drum is 18.5" (47 cm) from the floor when in horizontal position on the model 40. Model 40-30 is designed to tilt an upright 30-gallon (114 liter) steel drum to horizontal for dispensing.

The maximum full-drum capacity is 700 Lb. (318 kg).

MORSE Mfg. Co., Inc. E. Syracuse, NY	700 Lb. (318 kg)	Max. Capacity	Made in U.S.A.
---	------------------------------	-------------------------	----------------

Option

Model 31 Tipping Lever sold separately for use with Model 40 or Model 40-30 Drum Cradle assists in pulling over your heavy drum from upright onto the drum cradle. Constructed with 40" (101.6 cm) steel tubing with malleable iron double hook to engage the upper rim of your drum.

Maintenance

1. Periodically inspect all moving parts, framework and contact areas for signs of wear, fatigue or loosening. Tighten, adjust or replace parts as necessary to prevent failure and maintain proper function.
2. Apply a small amount of bearing grease to wheel bearing surface on each axle periodically.
3. Order replacement parts through your Morse Dealer.



Model 40 Cradle Truck shown with Optional Model 31 Tipping Lever.

Operator's Manual for Morse Drum Cradle Truck Models 40 and 40-30

Assembly Instructions

1. Attach Front Axle and Wheels
(Rear Axle will be installed last)

Remove paint from ends of each axle. Apply a small amount of bearing grease to wheel bearing surface on each axle. Slide one wheel (item 5) onto each end of both axles (item 6). With the angle iron on each side frame (item 1 & 2) facing away from each other (see diagram at right), insert threaded ends of axles into holes in side frames and hand tighten a 3/8 nut (item 7) onto each axle end.

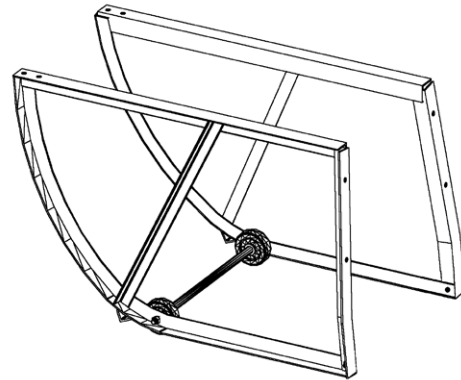

DO NOT TIGHTEN BOLTS UNTIL CRADLE TRUCK IS ENTIRELY ASSEMBLED

2. Attach Nose Piece

Fasten nose piece (item 4) to top of side frames using four 5/16 x 5/8" bolts (item 8). Hand tighten 5/16 nut (item 9) on each bolt.

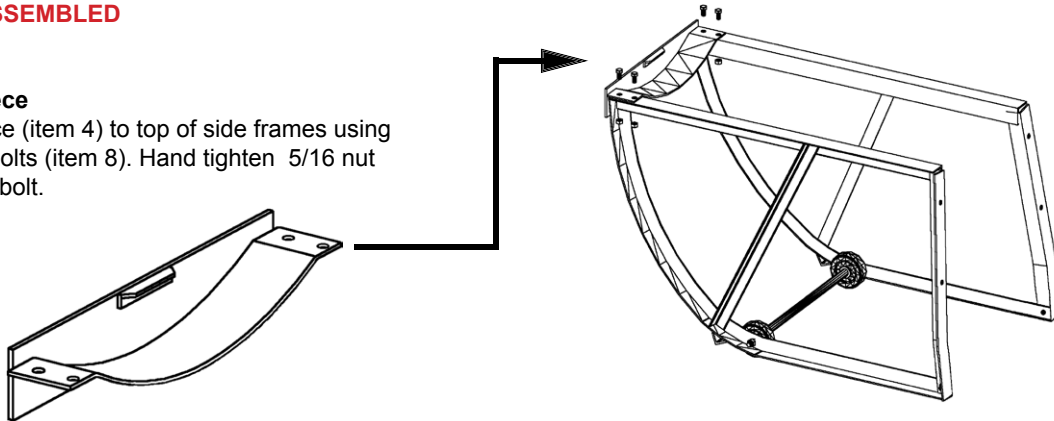

3. Attach Back Strap

Fasten back strap (item 3) to back of side frames using four 5/16 x 5/8" bolts (item 8) and 5/16 nuts (item 9). Hand Tighten each bolt.

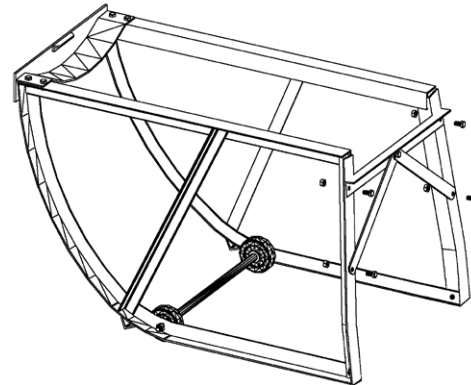

4. Attach Rear Axle

5. Tighten All Nuts and Bolts

Tighten bolts and nuts, alternating left and right to maintain straight frame.

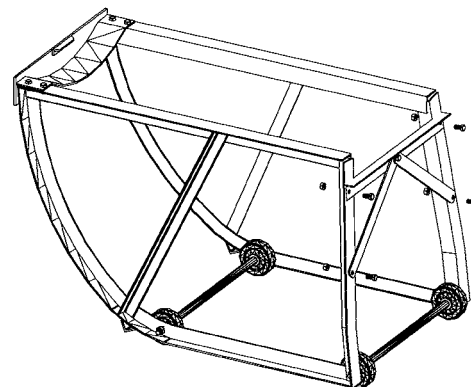

- For replacement parts, please contact your Morse dealer.
- When ordering parts, please specify:
- Part number and description
- Model and Serial numbers

Operator's Manual for Morse Drum Cradle Truck Models 40 and 40-30

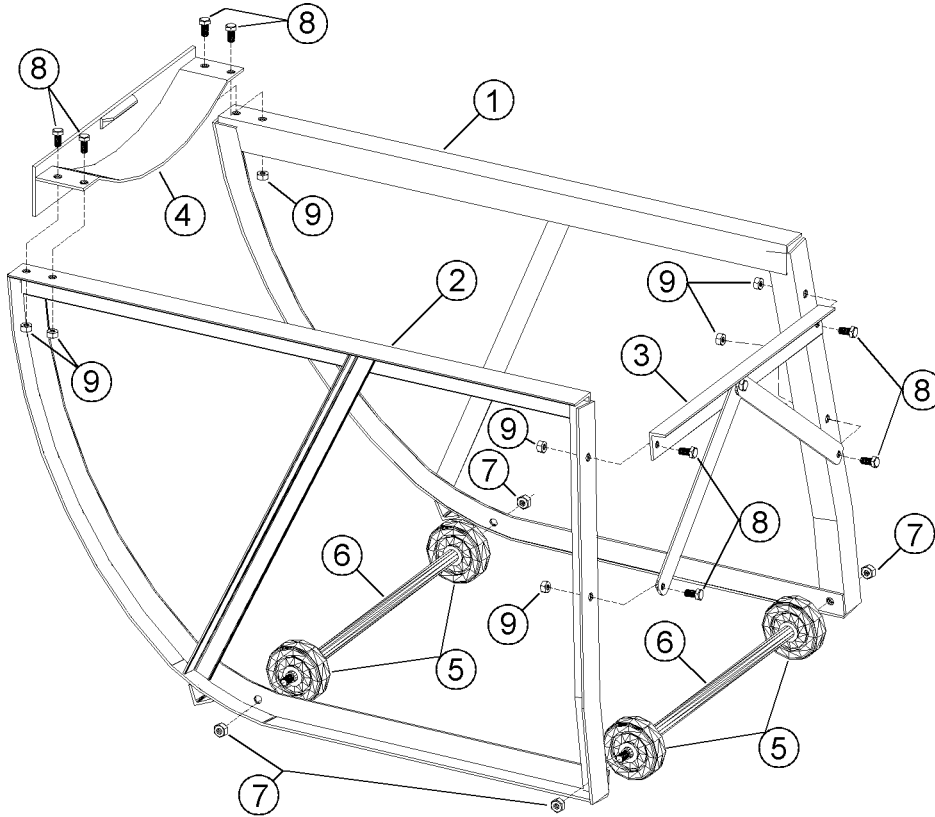

Model 40			
ITEM	QTY.	PART #	DESCRIPTION
1	1	1910L-P	SIDE FRAME WELD, LEFT, 40
2	1	1910R-P	SIDE FRAME WELD, RIGHT 40
3	1	1915-P	ASM, BACK STRAP, 40
4	1	1918-P	WELD, NOSE PIECE, 40
5	4	210-P	WHEEL, MORTUF 3" X 1/2"BORE 36
6	2	209-P	AXLE, 5/8" X 18", 40
7	4	1169-P	NUT, 3/8-16 REV HEX LOCK
8	8	215-P	HHCS, 5/16-18 X 5/8 GR2
9	8	172-P	NUT, 5/16-18 FIN HEX

Model 40-30			
ITEM	QTY.	PART #	DESCRIPTION
1	1	1910L-P	SIDE FRAME WELD, LEFT, 40
2	1	1910R-P	SIDE FRAME WELD, RIGHT 40
3	1	1922-P	ASM, BACK STRAP, 40-30 (NOT SHOWN)
4	1	1918-P	WELD, NOSE PIECE, 40
5	4	210-P	WHEEL, MORTUF 3" X 1/2"BORE 36
6	2	209-P	AXLE, 5/8" X 18", 40
7	4	1169-P	NUT, 3/8-16 REV HEX LOCK
8	8	215-P	HHCS, 5/16-18 X 5/8 GR2
9	8	172-P	NUT, 5/16-18 FIN HEX