

Replacement Parts List for Morse Part # 5522D-P Hydraulic Cylinder

Used on:

- Model 285A-BP and 285XBP Forklift-Karriers with serial numbers 1021 to ____ (MMYY)
- Model 289C and 289F Forklift Mounted Drum Rackers with serial numbers 319764 to ____
- 611 and 620 Series MORStak Drum Rackers with serial numbers 319968 to ____
- Model 910 < PILOT > MORStak Drum Racker with serial numbers 317043 to ____
- Model 290F Grip+GO™ Power-Grip Forklift Drum Handler with serial number 319424 to ____

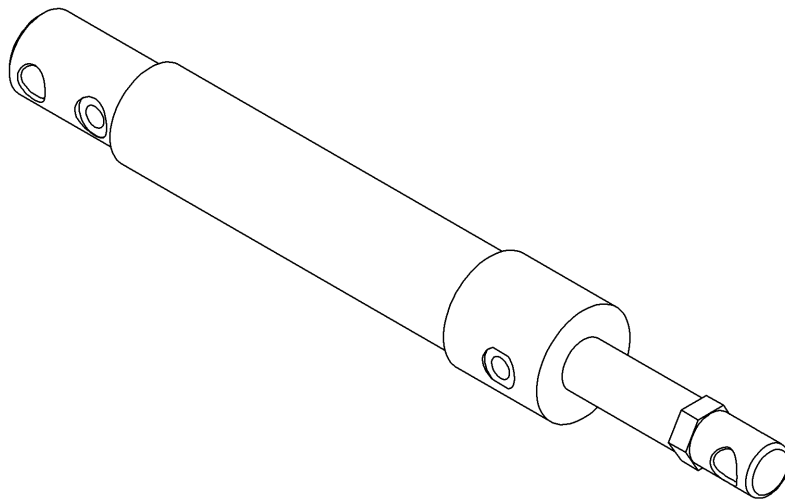

QTY.	PART #	DESCRIPTION
1	5522D-P	CYLINDER, 2 X 10 DOUBLE ACT DF
1	6661-P	KIT, SEAL, 2" CYL, 5522D-P DF

Note:

Stroke is 10" (25.4 cm)
 Length Closed: 19-3/4" to 20-1/8" (50.2 to 51.1 cm) Center to Center
 Length Fully Extended: 29-3/4" to 30-1/8" (75.6 to 76.5 cm) Center to Center



morsedrum.com



service@morsedrum.com



(315) 437-8475



103 Kuhn Rd.
 Syracuse, NY, 13208 U.S.A.