

**Operator's Manual for Morse Model 92-5M with**  
**4-Digit Serial Number 1015 to \_\_\_\_ (MMYY)**  
**6-Digit Serial Number 400000 to \_\_\_\_\_**

**Drum Lifter with Spark Resistant Parts**  
**for 11" to 15" Diameter Rimmed Drum**

For replacement parts, please contact your Morse dealer.

When ordering parts, please specify:

- Part number and description
- Model number
- Serial number

Find model number and serial number on metal name plate attached to frame.

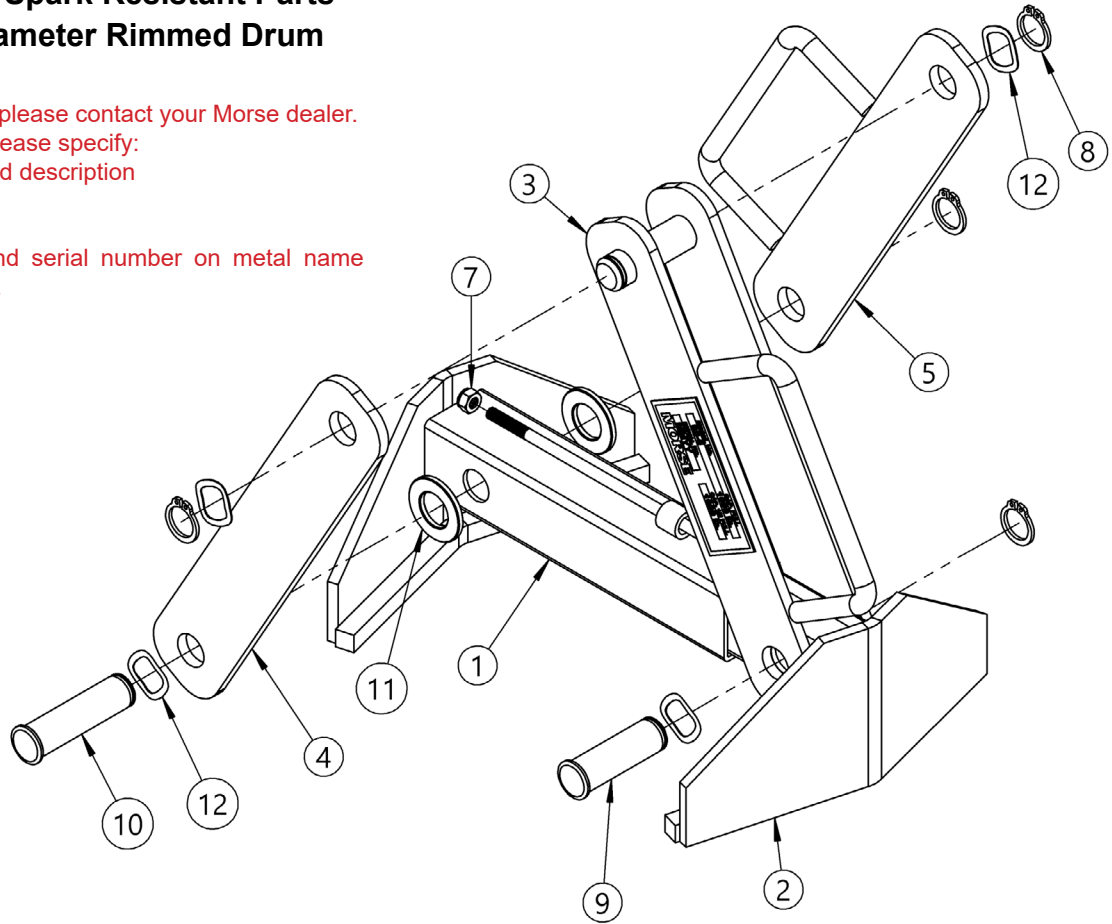

ITEM NO.	PART NUMBER	DESCRIPTION	QTY.
1	4420M-P	LARGE SLIDER TUBE WELD, SR	1
2	4421M-P	SMALL SLIDER TUBE WELD, SR	1
3	5588-5M-P	DOUBLE LINK WELD, 92-5M SR	1
4	4424M-P	LINK, 92-5M SR	1
5	4425M-P	LINK WELD W/ HANDLE, 92-5M SR	1
7	4250-P	NUT, 1/4-28 NYLON LOCK	1
8	5330-P	SNAP RING, EXT, HD, .078, 3/4"	4
9	5586L-P	PIN, GROOVE, 3/4 X 2.18 C	1
10	5585-P	PIN, GROOVE, 3/4 X 2.61 C	1
11	55-P	WASHER, 3/4 SAE FL 1-1/2 OD	2
12	4319-P	WAVE DISC SPRING, 3/4" .0105"	4