

Model 152 2-Wheel Drum Truck with rubber mold-on wheels

Capacity:
1000 Lb. (454 kg)



Model 153 2-Wheel Drum Truck with hard plastic wheels

Capacity:
1000 Lb. (454 kg)



Assembly Instructions (Model 152 shown)

1. Slide the Handle Assembly tube through the Hook Slide Weldment (item 3) and into the Base Assembly tube and align drilled holes.
2. Insert bolt (item 5) through the aligned holes and secure with Lock Nut (item 4) to fasten the Handle Assembly to the Base Assembly.

Note: Hook Slide Weldment slides freely on the Handle Assembly tube to engage the upper rim of your drum.

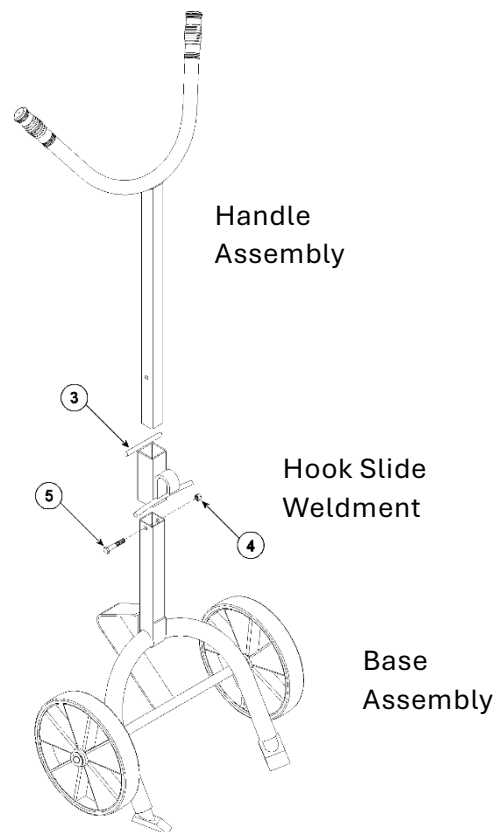

WARNING - This product can expose you to chemicals including barium sulfate, cobalt, titanium dioxide, and 2-methylimidazole, which are known to the State of California to cause cancer, and bisphenol-A, which is known to the State of California to cause birth defects or other reproductive harm. For more information go to www.P65Warnings.ca.gov

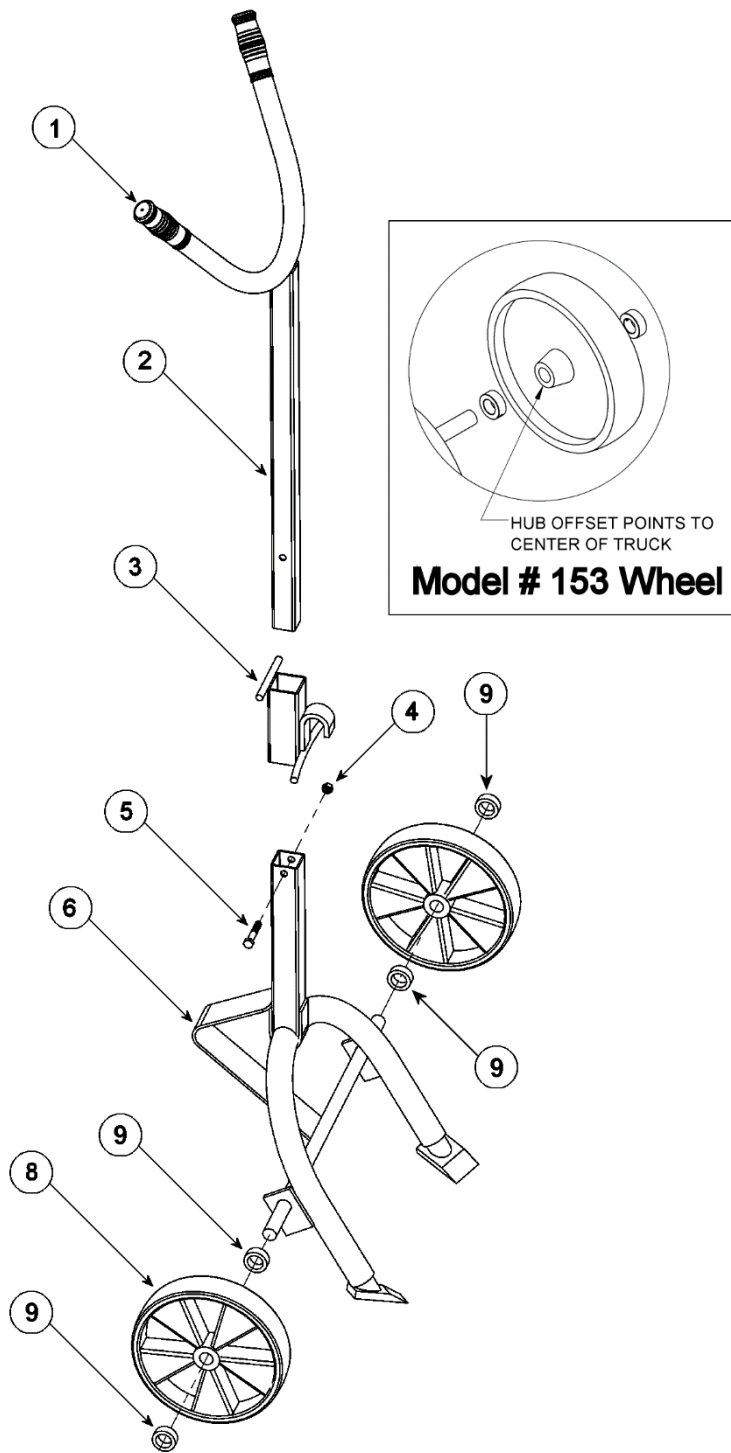

Model # 152 shown

Model 152			
ITEM	QTY.	PART NUMBER	DESCRIPTION
1	2	83-P	GRIP, HANDLE, 1-1/4 X 4-1/2
2	1	3970-P	HANDLE WELD, 152, 153, 155
3	1	1947-P	HOOK SLIDE WELD, 152
4	1	1169-P	NUT, 3/8-16 REV HEX LOCK
5	1	82-P	HHCS, 3/8-16 X 2-1/4 GR2
6	1	3971-P	BASE WELD, 152, 153
8 *	2	702-P	WHEEL, RUBBER, 10", 7/8" BORE
9 *	4	1850-P	COLLAR, 7/8" ID, 201B

Model 153			
ITEM	QTY.	PART NUMBER	DESCRIPTION
1	2	83-P	GRIP, HANDLE, 1-1/4 X 4-1/2
2	1	3970-P	HANDLE WELD, 152, 153, 155
3	1	1947-P	HOOK SLIDE WELD, 152
4	1	1169-P	NUT, 3/8-16 REV HEX LOCK
5	1	82-P	HHCS, 3/8-16 X 2-1/4 GR2
6	1	3971-P	BASE WELD, 152, 153
8 *	2	701-P	WHEEL, MORTUF, 10", 7/8" BORE
9 *	4	1850-P	COLLAR, 7/8" ID, 201B

* Recommended spare parts