

CONTENTS

- Receiving Procedures
- Warranty
- Safety Information
- Machine Description
- Accessories
- Installation Instructions
- Operating Instructions
- Maintenance
- Lost Load Calculation

Receiving Procedures

Every Morse drum handler is inspected prior to shipping. However, damage may be incurred during transit.

- Check for visible damage. If you choose to accept damaged freight, always sign noting the damage on the **BILL OF LADING**.
- Document the damage and have the truck driver sign. We recommend keeping a digital camera at your receiving dock for this purpose.
- Open packages expeditiously to check the condition of the goods. There is only a 24 hour window to notify the carrier of any concealed damage.
- **IMMEDIATELY REPORT ALL DAMAGE TO THE SHIPPING COMPANY!** Then you may contact Morse for assistance with your freight claim.
- Morse Manufacturing will not be held responsible for any damaged freight that is not signed for as damaged.

Delivery to non-business addresses without a loading dock result in additional freight charges. Residential delivery fees, inside delivery fees, re-delivery charges, and lift gate services will be added by the truck line, and are non-negotiable.

Limited 2 Year Warranty

Morse drum handling equipment is guaranteed against defects in workmanship or materials for **TWO YEARS** when used properly within its rated capacity. Warranty does not cover wear from normal use or

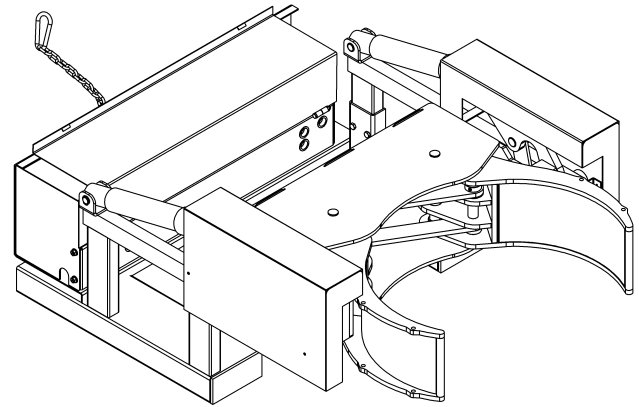

damage from accident or abuse. Motors and other purchased parts carry the warranties of their manufacturers.

For warranty claims, contact your Morse Dealer to obtain a return authorization number, and for return freight advice. Return freight must be prepaid.

In all instances, liability is limited to the purchase price paid or to repairing or replacing the product. Customer assumes liability for any modifications, unauthorized repairs or parts substitution.

Safety Information

While Morse Manufacturing Co. drum handling equipment is engineered for safety and efficiency, a high degree of responsibility must be placed upon the machine operator to follow safe practices, based primarily on common sense, upon which true safety depends.

Failure to follow the safety precautions in this manual can result in personal injury or property damage. Observe the same precautions as with similar machinery where carelessness in operating or maintenance is hazardous to personnel. Carefully read the safety precautions below and throughout this manual.

Review the Material Safety Data Sheet(s) for the material(s) in the drum(s) and take all necessary precautions. Safety shoes, work gloves, hard hat and other personal protective devices are recommended.

Prior to initial use, inspect all moving parts and test rotation of wheels. Perform necessary inspections, operator training, etc.













DANGER - Indicates a situation which, if not avoided, will result in serious injury or death. This signal word is limited to the most extreme situations.



WARNING - Indicates a situation which, if not avoided, could result in serious injury or death.



CAUTION - Indicates a situation which, if not avoided, can result in damage to the machine.

		CAUTION – Do Not Transport with Drum Raised - ALWAYS LOWER THE DRUM HOLDER TO LOWEST POSITION BEFORE TRANSPORTING. The unit can become unstable when transporting with a raised load.
		WARNING - The Power-Grip Fork Mount Drum Handler is designed to handle one drum of the types listed in the Machine Description. DO NOT attempt to handle any other type of drum or object. DO NOT exceed the weight capacity.
		WARNING - Do Not Modify the Unit - Under no circumstances should any modifications be made to the Morse machinery without factory authorization. Any modifications may void the warranty. This machine was designed to perform a specific job and alterations may result in injury to operator or machine.
		WARNING - Do Not Modify the Unit - Under no circumstances should any modifications be made to the Morse machinery without factory authorization. Any modifications may void the warranty. This machine was designed to perform a specific job and alterations may result in injury to operator or machine.
		WARNING - No Loose Fitting Clothing - Wear close-fitting clothing and safety equipment appropriate to the job. Loose fitting clothing may become caught on the machinery and cause severe personal injury.
		CAUTION - DO NOT allow drum to impact on floor, ground, or dumping station, etc.
		CAUTION - Wear Safety Shoes - Wear safety shoes with non-slip soles and hard toe protection.
		WARNING - This product can expose you to chemicals including barium sulfate, cobalt, titanium dioxide, and 2-methylimidazole, which are known to the State of California to cause cancer, and bisphenol-A, which is known to the State of California to cause birth defects or other reproductive harm. For more information go to www.P65Warnings.ca.gov
		WARNING - This product can expose you to chemicals including lead and arsenic, which are known to the State of California to cause cancer and birth defects or other reproductive harm. For more information go to www.P65Warnings.ca.gov

Machine Description

The Model 290F GRIP+GO Power-Grip Fork Mount Drum Handler is designed to lift, transport, and dispense a steel, plastic or fiber drum 14" to 24" (35.6 to 61 cm) in diameter.

The maximum capacity is 1500 Lb. (680 kg).



Accessories

Kit 6149-P Wireless Control

Provides safe, simple and reliable wireless machine grip and tilt control with up to 300 foot (91 m) operating range. It features 900MHz frequency hopping technology for eliminating interference from other RF sources. Easily switch between direct wire pendant control and wireless remote control. Quick DC power disconnect for locking out the equipment.



Kit 6978-P Drum Pads

Install larger Drum Grip Pads REQUIRED to handle a plastic or fiber drum.



Installation Instructions

BEFORE Operation, replace the **RED** shipping plug from the hydraulic reservoir with the supplied **BLACK** breather.

Operating Instructions

1. Before sliding forklift forks into the fork tubes, adjust forks to an inside spread of 24.5" (62.2 cm) minimum. Lock forks into position on the forklift carriage.
2. Drive the forklift forward to slip the forks into the fork tubes. Loop the carabiner and chain through the mast and securely attach to mast, ensuring no slack in the chain. Transport to drum to be handled.
3. With the **GRIP+GO** grippers in the full open position, drive the forklift with the forklift attachment near floor level to position the **GRIP+GO** around the middle of the drum between the ribs.
4. **Using Proper Grip Pressure:**
Press the GRIP "CLOSE" button to close the grippers around the drum, ensuring there is adequate pressure to handle the drum but not crush it.

Grip Pressure Adjustment:

With 11/16" wrench loosen lock nut. Then use 3/16" hex wrench to adjust the pressure control valve. Clockwise will increase the hydraulic pressure.

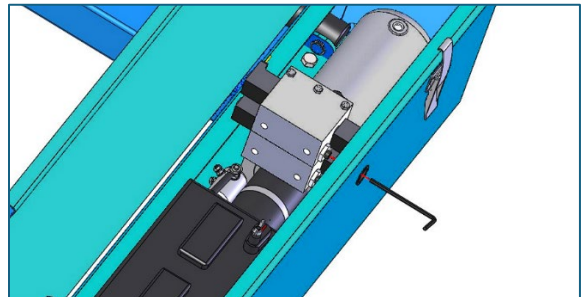
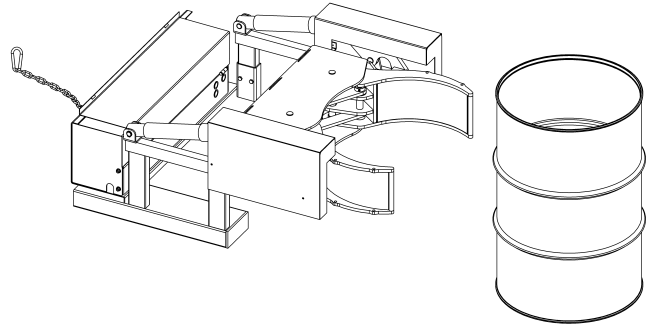

5. Raise forks to clear the floor and transport drum in vertical position to dispensing location.
6. To pour drum: Press the TILT "FWD" button on the pendant, rotating drum to angle required for dispensing.

IMPORTANT: Some drums can collapse a small amount as they empty during dispensing, which will reduce the grip pressure. It is important to monitor the grip pressure and ensure that the drum is secure in the grippers throughout dispensing. This may require tightening the grip on the drum by using the "GRIP CLOSE" button on the control pendant.
7. When dispensing is completed, rotate the drum back to vertical by pressing the TILT "REV" button on the pendant. While transporting, ensure that the drum is raised away from the floor to prevent the drum bottom from interfering with a pallet or other obstacle.
8. Lower drum to rest on floor, pallet, or other suitable surface.
9. To release drum grip, hold down the red SAFETY button, and press the GRIP "OPEN" button. The grippers will NOT open by pressing only the GRIP "OPEN" button.

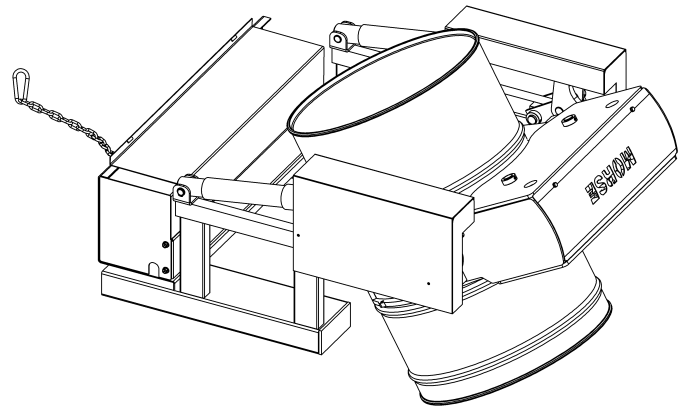
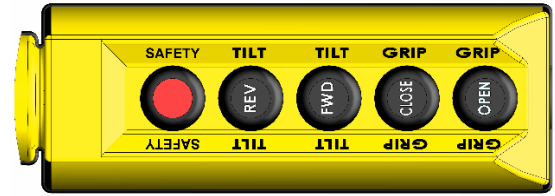

Maintenance

1. Using grease fittings to lube each end of the cylinder clevises in drum grab assembly. Recommended frequency: Every 6 months.
2. Clean and oil moving parts periodically. Clean & lubricate more often in environments where dust, dirt or other foreign particles will effect the performance of moving parts.
3. Periodic inspection for the general condition of structural and mechanical components is imperative for safe and efficient operation.
4. Periodically inspect all moving parts, framework, and contact areas for signs of wear, fatigue, or loosening. Tighten, adjust, or replace parts as necessary to prevent failure and maintain proper function.
5. Inspect the hydraulic system for oil drips, hose damage, or other signs of wear. Inspect the level and condition of the hydraulic fluid. Replace any parts that show signs of wear.
6. Worn or damaged parts must be properly replaced with the correct, genuine Morse parts.
7. Hydraulic pump is shipped filled with Noco Premium plus automatic transmission fluid d/m. Material safety data sheet (SDS / MSDS) is available online. Change oil yearly, or sooner depending on dirty conditions or outdoor use. Replace oil with Mobil dte 24 or equivalent for indoor use (Mobil dte 13 for outdoor use).

Center of gravity for Morse attachment combined with 1500 Lb. (680 kg) drum: Total = 2142 Lb. (972 kg).

Model 290F net weight: 630 Lb. (286 kg).

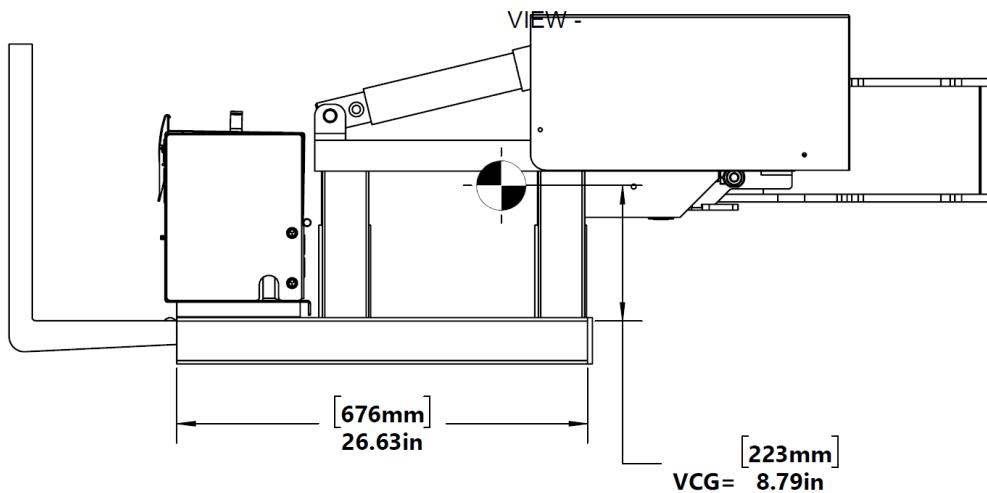
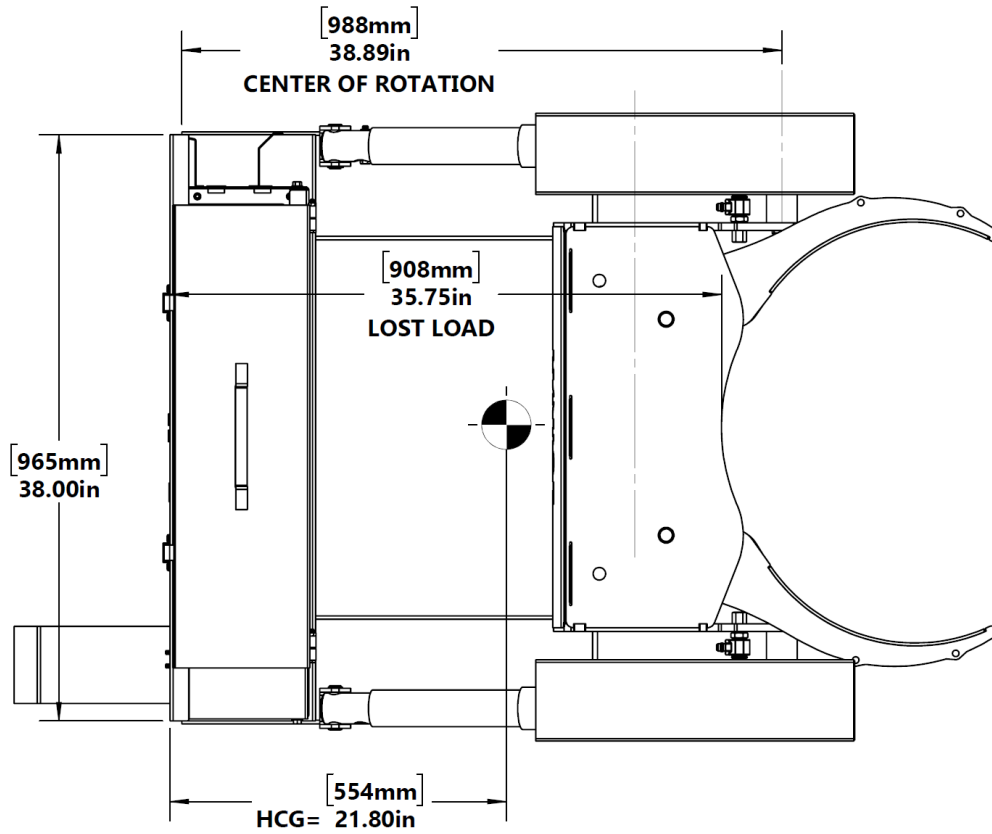

HGC – FORK LENGTH + 7.23" (183.6mm)

DIMENSIONS ASSUME FORKS ARE TOUCHING FORK TUBE END CAPS.